

# FIRE EXTINGUISHER BRACKET

CAT. **BRACKET2**  
**BRACKET5**

## DURABLE METAL CONSTRUCTION

Steel bracket with stainless steel straps

## CORROSION RESISTANT FINISH

Black coated finish resists corrosion,  
rust and chips.

## APPROVED FOR MARINE USE

Approved for marine use when used  
with the following First Alert fire  
extinguisher models:

### **BRACKET2:**

*FE5GR, FE10GR and FE1A10GR*

### **BRACKET5:**

*FE2A10GR, FE3A10GR, FE3A40GR*

# First Alert®

## Fire Extinguisher Bracket for 2.5 lb. and 5.0 lb. Fire Extinguishers

### Description:

First Alert Cat. No. BRACKET2 and BRACKET5 are heavy duty steel mounting brackets designed to fasten First Alert brand fire extinguishers in marine, automotive and in-cab truck applications or anywhere a more secure installation is needed. Their durable metal construction have a corrosion resistant coated finish with stainless steel straps.

The BRACKET2 is designed for 2.5 lb. First Alert fire extinguishers. The BRACKET5 is designed for 5.0 lb. First Alert fire extinguishers. When used with the following First Alert fire extinguisher models, they are approved to United States Coast Guard (U.S.C.G.) standards for marine applications, approval number 162.028/EX3622:

### **BRACKET2:**

FE5GR, FE10GR and FE1A10GR

### **BRACKET5:**

FE2A10GR, FE3A10GR, FE3A40GR



**BRACKET2**

**BRACKET5**



U.S.C.G. Marine  
Approved



# CAT. BRACKET2/BRACKET5

## TECHNICAL SPECS

Dimensions:	7.8"H x 2.0"W (BRACKET2) 8.3"H x 2.5"W (BRACKET5)
Weight:	0.49 lbs. (BRACKET2) 0.94 lbs. (BRACKET5)
Construction:	Black powder coated steel body with stainless steel straps
Application: (models)	FE5GR, FE10GR, FE1A10GR (BRACKET2) FE2A10GR, FE3A10GR, FE3A40GR (BRACKET5)

### OVERALL DIMENSIONS

BRACKET2

BRACKET5

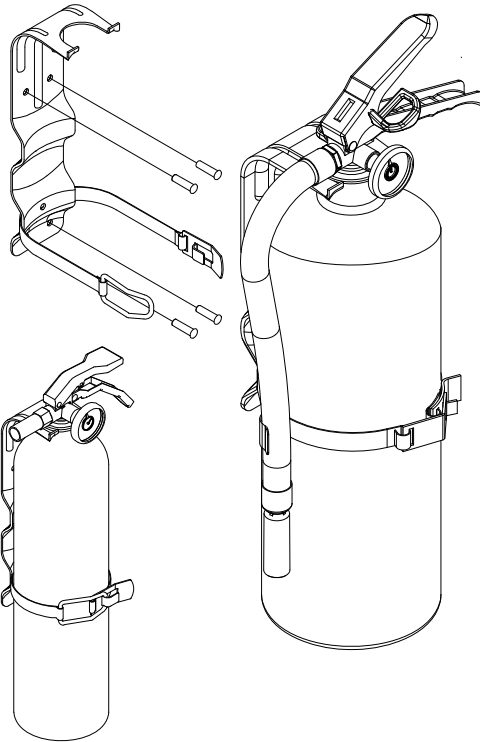
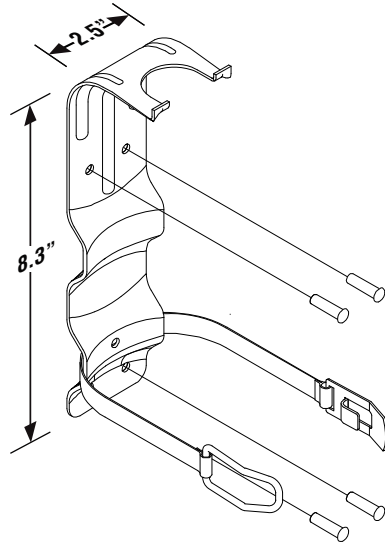
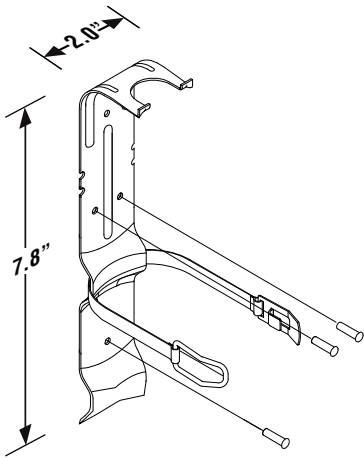

## SHIPPING SPECS:

Individual Carton Dimensions	3.63 "L x 2.19"W x 11.75"H (BRACKET2) 3.50 "L x 2.75"W x 14.25"H (BRACKET5)
Weight	0.68 lbs. (BRACKET2) 1.2 lbs. (BRACKET5)
Cube	0.05 ft3 (BRACKET2) 0.08 ft3 (BRACKET2)
UPC	0 29054 00100 9 (BRACKET2) 0 29054 00101 6 (BRACKET5)

Master Carton Dimensions	5.50 "L x 7.88"W x 12.32"H (BRACKET2) 4.25 "L x 6.81"W x 15.00"H (BRACKET5)
Master Pack	4 (BRACKET2) 2 (BRACKET5)
Weight	2.8 lbs. (BRACKET2) 2.5 lbs. (BRACKET5)
Cube	0.31 ft3 (FE3A40GR-2) 0.25 ft3 (FE3A40GR-6)
I2 of 5	600 29054 00100 1 (BRACKET2) 600 29054 00101 8 (BRACKET5)

Pallet Information	43 (BRACKET2) 65 (BRACKET5)
Cases per Layer	3
Number of Layers	129 (BRACKET2) 195 (BRACKET5)
Cases per Pallet	516 (BRACKET2) 390 (BRACKET5)
Units per Pallet	45.9 ft3 (BRACKET2) 55.2 ft3 (BRACKET5)
Cube	427 lbs. (BRACKET2) 557 lbs. (BRACKET5)
Weight	

## ARCHITECTURAL AND ENGINEERING SPEC

The fire extinguisher bracket shall be a First Alert Model BRACKET2 for 2.5 lb. applications and BRACKET5 for 5 lb. applications and shall provide at a minimum the following features and functions:

1. Steel construction with a corrosion resistant coating and stainless steel straps.
2. U.S. Coast Guard approved for marine use with approved bracket. Marine Type, U.S. Coast Guard Type-A-Size II, Type-B:C-Size I. Approval 162.028/EX3622. Valid only with bracket assembly BRACKET2 or BRACKET5 bracket numbers.
3. The unit shall at a minimum be listed to and meet the requirements of UL711, ULC-S508, UL299 and ULC-S504.



[View other knee pads made by BRK on our website.](#)