

INSTRUCTIONS

For Bon Models #24-515/#24-516

Floor Stripper

Includes Safety and Service Information

Do not discard this manual. Before operation, read and comprehend its contents. Keep it readily available for reference during operation or when performing any service related function. For replacement part information, see Bon Form # PL24515.



Bon[®]
Trusted since 1958

Table of Contents

DESCRIPTION	PAGE
<i>Notice to Operators</i>	3
<i>Operational Instructional Data Sheet</i>	4
Safety Precautions	6
PREPARATION.	6
OPERATION.	7
MAINTENANCE, REPAIR AND STORAGE.	8
<i>Assembly</i>	
REMOVING THE BON FLOOR STRIPPER FROM THE PALLET.	9
INSTALLATION OF THE ADJUSTABLE SECTION OF THE OPERATOR HANDLE.	9
<i>Before Starting the Motor</i>	10
THEORY OF OPERATION.	10
BLADE CONFIGURATIONS, ACCESSORY ATTACHMENTS AND APPLICATIONS.	11
INSTALLING A BLADE OR THE CERAMIC TILE RIPPER ATTACHMENT TO THE Bon Floor Stripper.	13
REMOVING THE BLADE OR THE CERAMIC TILE RIPPER ATTACHMENT FROM THE Bon Floor Stripper.	16
<i>Operation</i>	
OPERATIONAL DISCLAIMER.	18
CALIFORNIA PROPOSITION 65 DISCLAIMER.	18
TRANSPORTING THE BON FLOOR STRIPPER.	19
ADJUSTING THE OPERATOR HANDLE HEIGHT.	20
STARTING THE BON FLOOR STRIPPER ON THE JOB SITE.	21
OPERATING THE BON FLOOR STRIPPER ON THE JOB SITE.	23
STOPPING THE BON FLOOR STRIPPER ON THE JOB SITE.	27
OPERATIONAL PARAMETERS AND TECHNIQUES FOR THE BON FLOOR STRIPPER.	27
<i>Service</i>	29
PREVENTATIVE MAINTENANCE CHECK LIST.	29
LUBRICATION REQUIREMENTS.	30
ELECTRIC MOTOR SERVICE.	31
<i>Troubleshooting</i>	31
ELECTRIC MOTOR.	31
OPERATIONAL PROBLEMS.	31
<i>Storage</i>	32
<i>Specifications</i>	32

Notice to Operators

IF YOU CAN NOT READ OR DO NOT FULLY UNDERSTAND THE CONTENTS OF THIS MANUAL, PLEASE CONTACT THE FACTORY FOR PROPER ASSISTANCE BEFORE ATTEMPTING TO OPERATE THIS PRODUCT.



DANGER



CAUTION

These safety alert symbols identify important safety messages in this manual. When you see these symbols, be alert to the possibility of personal injury and carefully read the message that follows.

Do not allow anyone to operate the Bon Floor Stripper without first reading this Operator Manual and becoming familiar with its operation. The manufacturer of the Bon Floor Stripper has gone to great extremes to provide the owner(s) and/or operator(s) with the finest equipment available for its intended job function of removing covering materials from concrete and wood floor surfaces. Yet, the possibility exists that the Bon Floor Stripper can be utilized in and/or subjected to job applications not perceived and/or anticipated by the manufacturer. Such misuse and/or misapplication of the Bon Floor Stripper can lead to the possibility of serious damage, injury or even death. It is the responsibility of the owner(s) and/or operator(s) to determine that the Bon Floor Stripper is being utilized and/or operated within the scope of its intended job function. It is the responsibility of the owner(s) and/or operator(s) to establish, monitor and constantly upgrade all safety programs and/or practices utilized in and for the operation of the Bon Floor Stripper. The purpose of such programs is to provide for owner(s)' and/or operator(s)' safety. Operators must be instructed to recognize and avoid unsafe conditions associated with their work (29 CFR 1926.21 (b)(2)) and/or applicable updated revisions. It is the responsibility of the owner(s) and/or operator(s) to determine that no modifications and/or alterations have been made to the Bon Floor Stripper. Modifications and/or alterations can lead to the possibility of serious damage, injury or even death. It is the responsibility of the owner(s) and/or operator(s) to make this Operator Manual available for consultation during all phases of operation. Refer to OSHA 2207 and/or applicable updated revisions which contains all OSHA job safety and health rules and regulations (1926 and 1910) covering construction.



CAUTION

The concept of electrically powered, walk-behind type floor covering removal equipment has been successfully utilized for many years as a practical solution to many types of floor covering removal requirements. The basic concept is proven and well accepted within the associated marketplaces. Use of a Bon Floor Stripper requires strenuous work activity. This type of work activity can be considered to be greater in magnitude than that experienced with

the use of many other types of both light construction and lawn and garden related equipment. This type of work activity should only be attempted by operators of adequate physical size and stature, mental awareness and physical strength and condition. The body parts most noticeably affected during the covering removal process are the arms, hands, wrists, shoulders, lower back and legs. The process can also produce excessive stress/strain directly to the back muscles, spinal vertebrae and many other body parts. Back and wrist related pain can be side effects of utilizing a Bon Floor Stripper. A potential operator with a chronic back related problem or a history of back and/or other medically related problems should not attempt to utilize the Bon Floor Stripper. Use of the Bon Floor Stripper may only aggravate this and any other medically related problem. Because of the diverse type of prevailing job applications, job site conditions, operator experience levels and operator physical characteristics, no warranty, guarantee, representation and/or liability is made by the manufacturer as to the absolute correctness or sufficiency of any operational procedure, operational position and/or technique. There is no absolute guarantee that an operator of any given experience level, physical size and/or physical condition will be immune to the possibility of and/or probable physical side effects of the normal use of the Bon Floor Stripper. Each potential operator must be made aware of and assume the operational and physical liability described and/or associated with the use of the Bon Floor Stripper. Improper use of the Bon Floor Stripper can result in property damage and/or personal injury, including death. Each potential operator not willing to assume the operational and physical liability described and/or associated with the use of the Bon Floor Stripper, should not operate it. Proper levels of operator experience, skill and common sense are essential for maximizing the safe and efficient operation of the Bon Floor Stripper.

Record the Bon Floor Stripper and electric motor serial numbers in the spaces provided below.

_____ **Model Number**

_____ **Serial Number**

_____ **Electric Motor Serial Number**

_____ **Date of Purchase**

Specifications and design are subject to change without notice or obligation. All specifications are general in nature and are not intended for specific application purposes. Bon Tool Co reserves the right to make changes in design, engineering or specifications and to add improvements or discontinue manufacture at any time without notice or obligation. Bon Tool Co and its agents accept no responsibility for variations which may be evident in actual products, specifications, pictures and descriptions contained in this publication.

Operator Instructional Data Sheet

The following undersigned operators of the Bon Floor Stripper described and/or pertaining to this Operator Manual have received formal safety and operational information/instruction from the undersigned owner(s)/instructor(s) in accordance to OSHA 29 CFR 1926.21 (b)(2) and/or applicable updated revisions pertaining to, but not necessarily limited to the:

1) READING, COMPREHENSION AND ACKNOWLEDGEMENT OF THE MATERIAL COMPRISING THE ENTIRE CONTENTS OF THE APPLICABLE OPERATOR MANUAL AND APPLICABLE SAFETY AND OPERATIONAL INFORMATION VIDEO TAPE FOR BON FLOOR

STRIPPER.

2) FORMALIZED OPERATOR SAFETY PROGRAM TO BE DEvised BY THE OWNER OF THE Bon Floor Stripper IN CONJUNCTION WITH THE CONTENTS OF THE APPLICABLE OPERATOR MANUAL AND THE APPLICABLE SAFETY AND OPERATIONAL INFORMATION VIDEO TAPE FOR THE BON FLOOR STRIPPER.

3) OSHA RULES AND REGULATIONS RESEARCHED FOR AND/OR BY THE OWNER OF THE BON FLOOR STRIPPER AND DEEMED APPLICABLE TO THE SAFE AND PROPER USE AND/OR OPERATION OF THE BON FLOOR STRIPPER FOR ANY SPECIFIC JOB APPLICATION.

4) LOCAL LAWS, REGULATIONS AND CUSTOMS RESEARCHED FOR AND/OR BY THE OWNER OF THE BON FLOOR STRIPPER AND DEEMED APPLICABLE TO THE SAFE AND PROPER USE AND/OR OPERATION OF THE BON FLOOR STRIPPER FOR ANY SPECIFIC JOB APPLICATION.

5) FORMALIZED MAINTENANCE PROGRAM FOR THE BON FLOOR STRIPPER TO BE DEvised BY THE OWNER OF THE BON FLOOR STRIPPER IN ACCORDANCE WITH, BUT NOT NECESSARILY LIMITED TO, THE SPECIFICATIONS, GUIDELINES AND OPERATIONAL INFORMATION CONTAINED IN THE APPLICABLE OPERATOR MANUAL.

6) COMPREHENSIVE OPERATIONAL INSTRUCTIONS FOR THE CORRECT AND PROPER USE OF THE BON FLOOR STRIPPER AS PER THE CONTENTS OF THE APPLICABLE OPERATOR MANUAL AND THE APPLICABLE SAFETY AND OPERATIONAL INFORMATION VIDEO TAPE.

_____ Operator _____ Owner/Instructor _____ Date

_____ Operator _____ Owner/Instructor _____ Date

_____ Operator _____ Owner/Instructor _____ Date

_____ Operator _____ Owner/Instructor _____ Date

_____ Operator _____ Owner/Instructor _____ Date

_____ Operator _____ Owner/Instructor _____ Date

NOTE: INSERT COPIES OF THIS PAGE WITHIN THE OPERATOR'S MANUAL IF SPACE FOR ADDITIONAL OPERATORS IS REQUIRED.

Safety Precautions



THE FOLLOWING SAFETY PRECAUTIONS PROVIDE SOME COMMON SENSE GUIDES TO PROMOTE SAFETY AND EFFICIENCY WITH THE Bon Floor Stripper. NO WARRANTY, GUARANTEE OR REPRESENTATION IS MADE BY THE MANUFACTURER AS TO THE ABSOLUTE CORRECTNESS OR SUFFICIENCY OF ANY INFORMATION OR STATEMENT. THESE SAFETY PRECAUTIONS ARE INTENDED TO DEAL PRINCIPALLY WITH COMMON PRACTICES AND CONDITIONS ENCOUNTERED IN THE USE OF THE BON FLOOR STRIPPER AND ARE NOT INTENDED TO BE ALL INCLUSIVE. PROPER LEVELS OF OPERATOR EXPERIENCE, SKILL AND COMMON SENSE ARE ESSENTIAL FOR SAFE AND EFFICIENT OPERATION.



THE DUSTS/BYPRODUCTS FROM THE COVERING REMOVAL PROCESS ASSOCIATED WITH THE OPERATION OF THE BON FLOOR STRIPPER CAN CONTAIN CHEMICALS KNOWN TO THE STATE OF CALIFORNIA TO CAUSE CANCER, BIRTH DEFECTS OR OTHER REPRODUCTIVE HARM. THIS STATEMENT IS MADE IN COMPLIANCE TO CALIFORNIA PROPOSITION 65.



INCORRECT USE OF THE BON FLOOR STRIPPER CAN RESULT IN PROPERTY DAMAGE, PERSONAL INJURY OR EVEN DEATH. TO REDUCE THIS POSSIBILITY, GIVE COMPLETE AND UNDIVIDED ATTENTION TO THE JOB AT HAND AND FOLLOW THESE SAFETY PRECAUTIONS:

PREPARATION.

1) The Bon Floor Stripper is a specialized type of powered equipment, designed for a specific job function and requires adequate and thorough

instruction BEFORE it is operated. The size, power, complexity and operating characteristics of this type of powered equipment would dictate that each operator must receive adequate, professional instruction regarding the proper operation of the Bon Floor Stripper before being allowed to utilize it. BEFORE attempting to utilize the Bon Floor Stripper, read this Operator's Manual, and view the applicable Safety and Operational Information Video Tape to familiarize each operator with its correct operating procedures. Avoid the urge not to take the necessary time to read this Operator's Manual before operating the BON FLOOR STRIPPER. DO NOT OPERATE THE BON FLOOR STRIPPER UNTIL EACH OPERATOR COMPLETELY COMPREHENDS THE CONTENTS OF THIS MANUAL, THE APPLICABLE SAFETY AND OPERATIONAL INFORMATION VIDEO TAPE AND APPLICABLE SUPPLEMENTAL INFORMATION.

2) Develop a comprehensive program for the safe operation of the Bon Floor Stripper by its owner(s) and/or operator(s). Such a program will include, but is not limited to: instructional requirements for operation, applicable OSHA requirements, local laws and regulations, job site safety and a Bon Floor Stripper maintenance program. Constantly examine and upgrade this program to guarantee owner(s) and/or operator(s) safety. Each operator must be fully instructed regarding the specifics of this safety program.

3) Determine that the Bon Floor Stripper is in its original, factory configuration and has not been modified in any manner. Many modifications can result in potentially dangerous configurations that can lead to property damage and/or personal injury. If there are any questions about possible modifications made to the Bon Floor Stripper, contact the Customer Service Department for specific information BEFORE utilization. There is no charge for this service.

4) Minors should never be allowed to operate the Bon Floor Stripper. Bystanders, especially children and animals, should not be allowed in the area where the Bon Floor Stripper is in use. The covering removal process can result in flying particles being emitted at high velocity and striking the operator and/or onlookers. This can lead to the possibility of property damage and/or personal injury. Keep all body parts, loose clothing, foreign objects and onlookers clear while equipment is in operation.

5) Operators must be in proper physical condition, mental health and not under the influence of any substance (drugs, alcohol, etc.) which might impair vision, dexterity or judgment. Working with the Bon Floor Stripper is strenuous. If you have any condition

that might be aggravated by strenuous work, check with your doctor BEFORE operating the Bon Floor Stripper. Guard against the possibility of back related injuries. Always lift the Bon Floor Stripper with leg muscles and not with the back.

6) Prolonged use of the Bon Floor Stripper (or other, similar machines) exposes the operator to vibrations which may produce Whitefinger Disease (Raynaud's Phenomenon). This phenomenon reduces the hand's ability to feel and regulate temperature, produces numbness and burning sensations and may cause nerve and circulation damage and tissue necrosis. Antivibration systems do not guarantee that you will not sustain Whitefinger Disease. Therefore, continuous and regular users should closely monitor the condition of their hands and fingers. After each period of use, exercise to restore normal blood circulation. If any of the symptoms appear, seek medical advice immediately.

7) Clothing must be sturdy and snug fitting, but allow complete freedom of movement. Never wear loose fitting jackets, scarves, neckties, jewelry, flared or cuffed pants or anything that could become caught on controls or moving parts. Wear long pants to protect your legs. Protect your hands with heavy duty, nonslip gloves to improve your grip. Good footing is most important when operating the Bon Floor Stripper. Wear sturdy boots with nonslip soles. Steel-toed safety shoes are highly recommended. Keep shoes properly laced. Never wear tennis shoes or other, similar type shoes which afford little or no protection. Wear an approved safety hard hat to protect the operator's head(s) where there is a danger of head injuries. Noise, generated by the operation of the Bon Floor Stripper and the actual process itself, can damage your hearing. Wear approved sound barriers (ear plugs or ear muffs) to protect your hearing. Continuous and regular operators should have their hearing checked regularly.

8) Visually inspect the Bon Floor Stripper, blade(s), and accessories for damaged or worn parts. Check for loose and/or broken parts. Determine that operator controls work freely, all safety devices are operative and information/safety decals are readable. Check to determine that the Bon Floor Stripper and all related accessories are in good mechanical condition BEFORE utilization.

9) The Bon Floor Stripper and related accessories are not classified as being insulated. Contact with electrical cables, gas lines and other hazardous items can result in electrocution and/or an explosion.

10) Know how the controls operate. Know how to stop the motor quickly in an emergency. Always start the motor according to the instructions as outlined in this manual to minimize the possibility of unexpected or uncontrolled blade/accessory oscillation. Unexpected blade/accessory rotation can cause loss of machine control, and the possibility of property damage and/or personal injury.

11) Never exceed the recommended capacities of the Bon Floor Stripper. Refer to the **Specifications** section of this manual for more detailed information. Always utilize the correct blade and extension cord designed for use with the Bon Floor Stripper. Use of an incorrect blade or extension cord can result in property damage and/or personal injury.

OPERATION.

1) Give complete and undivided attention to the job at hand. Do not chew gum, smoke and/or use smokeless tobacco while utilizing the Bon Floor Stripper. Do not attempt to eat and/or drink while utilizing the Bon Floor Stripper. Determine that eyeglasses, hearing aid devices and other medical related devices are properly secured. Keep shoes properly laced. Use of the Bon Floor Stripper is strenuous and causes fatigue. Help prevent the cause of an accident. Plan to take work breaks as required to help maintain proper mental and physical alertness.

2) The Bon Floor Stripper is not sealed or insulated. Do not operate the Bon Floor Stripper in an explosive atmosphere or near combustible materials. Refer to current OSHA rules and regulations.

3) The Bon Floor Stripper is designed for use by one operator. Use of the Bon Floor Stripper by more than one operator can lead to confusion and loss of control, resulting in property damage and/or personal injury. Never operate the Bon Floor Stripper with an improper number of operators. Such a configuration can result in property damage and/or personal injury. If it is felt that more than one person is required to furnish additional "force" to the blade, STOP and contact the Customer Service Department for specific operational and service/maintenance information. There is no charge for this service.

4) Do not operate the Bon Floor Stripper with onlookers close by. Caution all onlookers to stand clear. The coverings removal process can result in flying particles being emitted at high velocity and striking the operator and/or onlookers. This can lead to the possibility of property damage and/or personal injury. Keep all body parts, loose clothing and foreign objects clear of the oscillating blade/accessory.

5) Start the motor according to the instructions as outlined in this manual to minimize the possibility of unexpected blade/accessory oscillation. Unexpected blade/accessory oscillation can result in the loss of machine control and the possibility of property damage and/or personal injury.

6) Operate the Bon Floor Stripper only when/where visibility and light are adequate for the job at hand. Work carefully. Always hold the operator handle firmly with both hands. Wrap your fingers around the handle grips, keeping them cradled between your thumbs and fingers. Always determine the operator handle is in good condition and free of moisture, pitch, oil or grease. Wear gloves to improve your grip. Never leave the Bon Floor Stripper running unattended.

7) Stop the motor while moving and/or repositioning the Bon Floor Stripper on the job site. Allowing the motor to remain operating substantially increases the potential for property damage and/or personal injury. Special care must be exercised on slippery conditions and on difficult, uneven surfaces. Watch for cracks, high spots and other surface irregularities. Keep proper footing and balance at all times. The normal use of this machine is on level surfaces. Other terrains can be dangerous and should be avoided. Only properly trained operators should attempt these techniques.

8) Because the Bon Floor Stripper is classified as a low cost, low horsepower, portable type machine, it is limited in the number of practical and/or suitable job applications. A particular job site, actual surface conditions, job specifications and operator skill/common sense may dictate that a different type of machine (with characteristics of higher purchase cost, being mounted to a carrier vehicle, with greater horsepower and less mobility), method and/or process be utilized to properly complete the job with the degree of efficiency and safety required. Contact the Customer Service Department for specific information regarding suitable job applications, job site surface conditions and operator experience/skill/common sense recommendations for the Bon Floor Stripper BEFORE utilization. There is no charge for this service.

MAINTENANCE, REPAIR AND STORAGE.

1) Use only genuine, approved replacement parts and accessories for maintenance and repair. Use of parts and accessories manufactured by others can result in property damage and/or personal injury.

2) Follow the Service instructions as outlined in the appropriate section of this manual.

3) Always stop the motor and disconnect the extension cord BEFORE checking or working on the Bon Floor Stripper.

4) Always properly maintain the Bon Floor Stripper. Frequently check all fasteners and individual parts. Built in safety features are effective only if they are maintained in good working condition. Replace any questionable part or assembly with a genuine, factory approved, replacement part. Do not forsake proper maintenance for the price of a few replacement parts. Proper maintenance does not cost...it actually pays dividends. Do not attempt any maintenance repair work not described in this manual. Have such work performed at your dealer's service facility.

5) Maintain all safety and operation decals in proper condition. If any decal becomes damaged and/or unreadable, replace with a genuine, factory approved, replacement part only.

6) The Bon Floor Stripper may utilize self locking type hexagon head nuts to minimize the effects of vibration. Replace all self locking hardware with genuine, factory approved, replacement parts only.

7) Consult the material supplied by the motor manufacturer for specific information relative to proper operational, lubrication and storage requirements.

Assembly

The Bon Floor Stripper is shipped from the factory secured on a specially designed wooden pallet and protected from external damage by a corrugated carton or wood crate. If shipped with a corrugated carton, the Surface Grinder is secured to the pallet with wood support strips. Remove the carton or crate immediately upon receipt using suitable tools to remove the nails.

REMOVING THE Bon Floor Stripper FROM THE PALLET.

Tools Required:

- 1 each - cutting type pliers
- 1 each - claw hammer or a hammer and an appropriate pry bar

Remove the corrugated carton which is fastened to the pallet. The Bon Floor Stripper is secured to the pallet with banding. Using the pliers, cut and remove the banding. The Bon Floor Stripper can then be removed from the pallet.



DANGER

WEAR SAFETY GLASSES AND OTHER APPROPRIATE SAFETY APPAREL WHEN CUTTING THE BANDING AND/OR REMOVING THE CORRUGATED/WOOD SHIPPING CRATE.

Included in the shipment should be the following:

- 1 each - Bon Floor Stripper main frame assembly
- 1 each - Extension cord with integral GFI
- 1 each - Adjustable section of the operator handle
- 1 each - Pack of standard blades

The Bon Floor Stripper is shipped from the factory completely assembled with the exception of the adjustable section of the operator handle. If ordered with the Bon Floor Stripper, optional blades and accessories can be shipped separately or included in the shipping container.

Visually inspect the shipment for freight damage and/or missing parts. If shipping damage is evident, contact the delivering carrier immediately to arrange for an inspection of the damage by its claims representative. Federal law requires that a claim be filed within a specific time period. If missing parts are

detected, notify your dealer or the Customer Service Department who will assist you in obtaining them.

Check all fasteners for proper security. Consult a fastener torque chart for the proper torque value if any fastener is found to require retorquing.

INSTALLATION OF THE ADJUSTABLE SECTION OF THE OPERATOR HANDLE.

The installation of the adjustable section of the operator handle will require a level working surface of sufficient size and appropriate height.

- 1) The Bon Floor Stripper incorporates an operator handle design that folds for transport and storage. The handle is secured to the main frame at two locations; a pivoting (fixed) location secured by Allen head type cap screws and a retaining (locking) location secured by removeable, ball-detent type pins. The pins are secured to the main frame by lanyards.
- 2) To place the operator handle in the work position, move the handle upright so that the ball-detent pins can be inserted through the operator handle and main frame. Determine the ball-detent pins are properly inserted through the operator handle and main frame to fully expose the ball detent. FIGURE 1.



FIGURE 1



DANGER

THE BALL DETENT MUST BE FULLY EXPOSED AGAINST THE MAIN FRAME TO PROVIDE THE PROPER PIN RETAINING FORCE. AN IMPROPER PIN RETAINING CONFIGURATION CAN RESULT IN UNEXPECTED OPERATOR HANDLE

MOVEMENT. THIS OCCURRENCE CAN RESULT IN PROPERTY DAMAGE AND/OR PERSONAL INJURY.

3) Remove the threaded knobs from the fixed section of the operator handle. Install the adjustable section into the fixed section with the handle grips facing backwards toward the operator. FIGURE 2. Position the adjustable section at a comfortable height. Reinstall the threaded knobs and tighten until the studs thrust up tight against the adjustable handle section.



CAUTION

The ergonomic design considerations of the adjustable section of the operator handle will only function if the handle grips are installed facing backwards (toward) the operator. Installing the adjustable section of the operator handle with the handle grips facing forward (away) from the operator will decrease machine control and productivity.



DANGER

INSTALLING THE ADJUSTABLE SECTION OF THE OPERATOR HANDLE WITH THE HANDLE GRIPS FACING FORWARD (AWAY) FROM THE OPERATOR WILL NOT ALLOW THE THREADED STUDS TO PROPERLY LOCATE WITHIN THE SLOTS OF THE ADJUSTABLE HANDLE. THE SLOT ENDS FORM INTEGRAL STOPS FOR THE THREADED STUDS TO THRUST AGAINST. A PROPER STUD/SLOT CONFIGURATION WILL PREVENT THE ADJUSTABLE HANDLE FROM INADVERTENTLY SEPARATING FROM THE FIXED SECTION WHEN TRAVERSING AN INCLINE SUCH AS A STAIRWAY. INADVERTENT SEPARATION OF THE ADJUSTABLE HANDLE SECTION CAN RESULT IN PROPERTY DAMAGE AND/OR PERSONAL INJURY.



DANGER

IMPROPER KNOB TENSION AND/OR IMPROPERLY SECURING THE OPERATOR HANDLE TO THE MAIN FRAME CAN

RESULT IN AN UNSTABLE PLATFORM CONFIGURATION. AN UNSTABLE PLATFORM CONFIGURATION CAN RESULT IN PROPERTY DAMAGE AND/OR PERSONAL INJURY.



FIGURE 2

Before Starting the Motor

THEORY OF OPERATION.

The Bon Floor Stripper is designed to operate on the principle of various blades and/or attachments oscillating with a random orbital movement to remove a wide variety of covering materials from work surfaces. Various types of multi-accessory blades and/or accessory attachments are secured to the exciter plate located on the bottom of the machine. The specific type of blade and/or accessory attachment utilized directly affects the type of material removed, the material removal rate and the resulting smoothness of the work surface.

The coverings removal process is directly controlled by these conditions:

- 1) The use of a suitable mechanism (blade or accessory attachment) of proper design and configuration to scrape against the work surface and remove material while delivering an acceptable service life.
- 2) Sufficient static weight supporting the blade or accessory attachment to allow it to effectively penetrate and remove the covering material.

3) Adequate force exerted against the Bon Floor Stripper by the operator that pushes the blade or accessory attachment against the covering material to deliver acceptable productivity rates.

4) Since no two covering materials are exactly alike, no two covering materials can be removed by the exact same method. The nature of the covering removal process, along with operator experience, skill and common sense, would suggest that efficient and productive material removal is a matter of trial and error.

Combinations of blade or accessory attachment type, job site conditions, and feed rates are direct factors that will also determine the overall success of the job application.

BLADE CONFIGURATIONS, ACCESSORY ATTACHMENTS AND APPLICATIONS.

Bon Floor Stripper blades are fabricated from high carbon steel, precision machined and heat treated for extended service life. Blades are marked to depict use on either concrete or wood surfaces. When utilized on concrete, the cutting edge is positioned facing up.

FIGURE 3. On wood flooring surfaces, the cutting edge faces down against the surface.

FIGURE 4. This configuration allows the blade to skim over the surface and minimize any tendency to gouge or dig into the wood. A slotted blade configuration is employed to lower installation and removal time. The slotted configuration is also intended to help minimize direct exposure of hands, arms and other body parts to the blade during the installation or removal process.

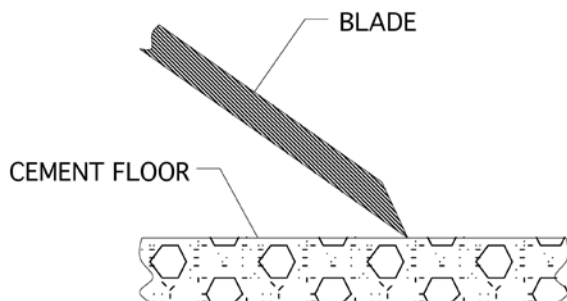

FIGURE 3

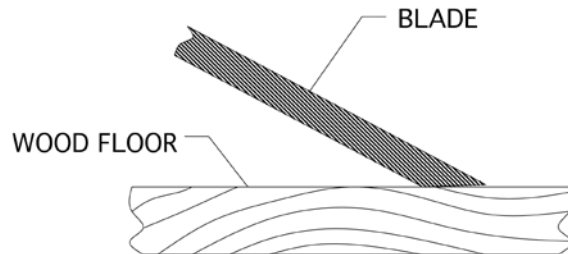

FIGURE 4

A protective covering is provided to protect the blade cutting edge from external damage and minimize the potential for property damage and/or personal injury.



CAUTION

Store the blade with the protective covering properly installed to minimize the effects of external damage to the cutting edge and the potential for property damage and/or personal injury.



DANGER

THE BLADE IS EXTREMELY SHARP. IMPROPER HANDLING WHILE REMOVING FROM THE PACKAGE, REMOVING/REINSTALLING THE PROTECTIVE CUTTING EDGE COVER, INSTALLING/REMOVING FROM THE MACHINE OR WHILE IMPROPERLY TRANSPORTING CAN RESULT IN PROPERTY DAMAGE AND/OR PERSONAL INJURY.

While individual blade or accessory attachment design and configuration may vary, basic operational characteristics are identical: impact against a floor surface and remove the covering material. This common operational characteristic has led to the development of the following popular blade configurations and accessory attachments:

Angled mastic removal blade.

This blade configuration is utilized to remove a wide variety of adhesives, mastics and material residues from concrete surfaces. The steep angle increases the cutting edge position relative to the floor surface. The angle increase allows the blade to better penetrate the material and then shear and scrape it from the floor surface. The cutting edge faces down toward the floor surface. Angled mastic blades are utilized on concrete surfaces only. Use on wood surfaces will only dig into and remove substrate material. FIGURE 5.

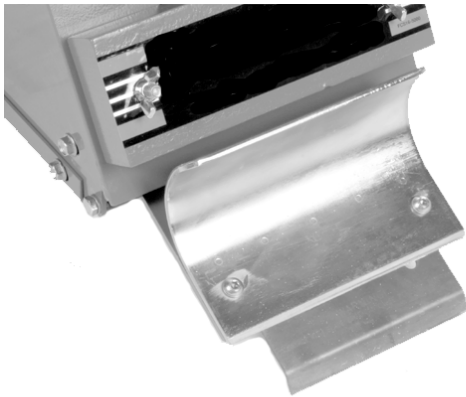

FIGURE 5

Straight beveled cutting edge blade.

This blade configuration is utilized to remove a wide variety of VCT and linoleum tiles along with general material removal from concrete and wood surfaces. Some blades feature two cutting edges. Position the blade edge facing up for use on concrete surfaces. Flip the blade over for use on wood surfaces. Specific blades are available for removing covering materials from either concrete or wood surfaces. This blade design does not allow it to be flipped over for use on both concrete and wood surfaces. FIGURE 6.



FIGURE 6

Straight beveled scoring blades.

This blade configuration is utilized to remove glued type carpet and soft sheet type (PVC, rubber, linoleum, etc) materials from concrete and wood surfaces. FIGURE 7. The cutting wings score the covering material to aid in removal. Specific part numbers are available for removing covering materials from either concrete or wood surfaces. The blade design does not allow it to be flipped over for use on both concrete and wood surfaces.



CAUTION

Use of a straight beveled scoring blade with the cutting wings positioned down and against the work surface can result in unreparable surface damage and personal injury.



FIGURE 7
Ceramic tile ripper attachment.

This attachment is designed for light to medium duty projects requiring the removal of ceramic, thicker VCT and linoleum tiles, hardwood floors, etc, from concrete and wood surfaces. FIGURE 8.



FIGURE 8

CAUTION

The primary design function for the BON FLOOR STRIPPER is not to remove ceramic tile. Removing ceramic tile is a secondary job application that may require the use of a machine and/or process with significant greater stability, power and/or impact force. The Bon Floor Stripper has demonstrated the ability to remove ceramic tile for those job applications classified as light to medium duty. An improper job application for the Bon Floor Stripper may result in property damage and/or personal injury.

INSTALLING A BLADE OR THE CERAMIC TILE RIPPER ATTACHMENT TO THE BON FLOOR STRIPPER.

Tools required: 1 each, 5/32 inch T-handled Allen wrench provided with the machine.

Parts required: 1 each, blade appropriate for the job application or the ceramic tile ripper attachment.



DANGER

WHEN INSTALLING OR REMOVING A BLADE OR THE CERAMIC TILE RIPPER ATTACHMENT TO/FROM THE BON FLOOR STRIPPER ALWAYS WEAR THE APPROPRIATE SAFETY EYEWEAR, GLOVES, LEATHER SHOES AND LONG PANTS TO MAXIMIZE PERSONAL PROTECTION FROM THE SHARP EDGE(S). IMPROPER CONTACT WITH A SHARP EDGE CAN RESULT IN PROPERTY DAMAGE AND/OR PERSONAL INJURY.

- 1) Properly disconnect the extension cord or the Bon Floor Stripper from the power source.
- 2) To place the operator handle in the work position, move the handle upright so that the ball-detent pins can be inserted through the operator handle and main frame. Determine the ball-detent pins are inserted through the operator handle and main frame to fully expose the ball detent. FIGURE 9.



FIGURE 9

⚠ DANGER

THE BALL DETENT MUST BE FULLY EXPOSED AGAINST THE MAIN FRAME TO PROVIDE THE PROPER PIN RETAINING FORCE. AN IMPROPER PIN RETAINING CONFIGURATION CAN RESULT IN UNEXPECTED OPERATOR HANDLE MOVEMENT. THIS OCCURRENCE CAN RESULT IN PROPERTY DAMAGE AND/OR PERSONAL INJURY.

3) Loosen the threaded handle knobs and extend the operator handle out until it stops against the threaded studs. Retighten the knobs. FIGURE 10.



FIGURE 10



CAUTION

Improper knob tension and/or improperly securing the operator handle to the main frame can result in an unstable platform configuration. An unstable platform configuration can result in property damage and/or personal injury.

4) Tilt the Bon Floor Stripper back until the operator handle comes in contact with the surface. The Bon Floor Stripper may not be in a stable position in this configuration. To minimize the possibility of property damage and/or personal injury, properly secure an appropriate weight to the handle for added stability. Other means can also be utilized to support the frame and provide proper machine stability. Appropriate wheel chocks are also recommended. FIGURE 11.

⚠ DANGER

EXERCISE EXTREME CAUTION WHEN WORKING NEAR OR UNDER THE RIP-R-STRIPPER WITH THE OPERATOR HANDLE TILTED BACK IN THE SERVICE POSITION. IF THE Bon Floor Stripper IS NOT POSITIONED IN A STABLE CONFIGURATION, WITH ADEQUATE COUNTERWEIGHT PROPERLY SECURED, UNEXPECTED MOVEMENT CAN ALLOW THE MACHINE TO FALL BACK TO THE WORK SURFACE. THIS OCCURRENCE CAN RESULT IN PROPERTY DAMAGE AND/OR PERSONAL INJURY.



FIGURE 11

5) Wear proper safety apparel and equipment. Use the T-handled Allen wrench to loosen the button head cap screws which secure the fence plate to the exciter plate. This will allow the blade to slide in between the fence plate and the exciter plate. IT IS NOT NECESSARY TO REMOVE THE FENCE PLATE FROM THE EXCITER PLATE. The fence plate has an integral stop which the edge of the blade thrusts up against. FIGURE 12. Blades are provided with a covering that protects the cutting edge. Do not remove the protective covering until you are ready to operate the Bon Floor Stripper. Exercise extreme caution when removing and/or reinstalling the protective cover.



FIGURE 12

6) Two attachment configurations for blades are utilized. Narrow (less than 6 inches (152 mm) wide) blades are positioned between the two button head cap screws and thrust up against the fence plate stop. FIGURE 13. Use the T-handled Allen wrench to tighten the button head screws. Wider (greater than 6 inches (152 mm) wide) blades incorporate a slotted design which slides around the button head cap screws. The slots afford increased clamping pressure for the wider blades during the covering removal process. SLOTS ALSO MAKE IT UNNECESSARY TO REMOVE THE FENCE PLATE FROM THE EXCITER PLATE. Use the T-handled Allen wrench to tighten the button head cap screws. FIGURE 13. If the Bon Floor Stripper is to be utilized immediately, remove the protective cover from the blade. If the Bon Floor Stripper is not to be utilized immediately, do not remove the protective covering from the blade.

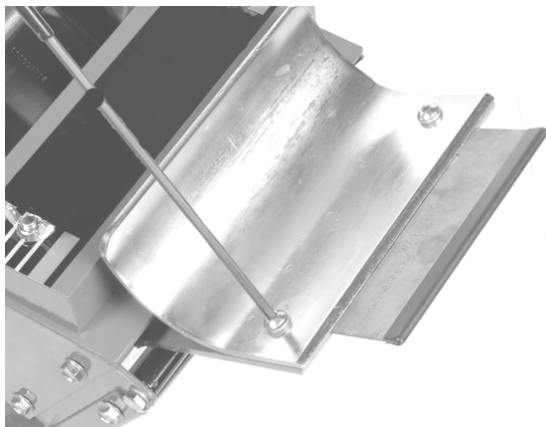

FIGURE 13

7) The installation of the ceramic tile ripper attachment is similar to that of a blade with the exception that the fence plate is removed from the exciter plate. The ceramic tile ripper attachment fastens directly to the exciter plate. Follow the same tightening procedure as with a blade. FIGURE 14.



FIGURE 14



CAUTION

For all blades and the ceramic tile ripper attachment, tighten the button head cap screws with the T-handled Allen wrench provided. Do not utilize another wrench type and/or configuration. The T-handled Allen wrench was chosen to place body parts a practical distance from the blade during the faster tightening and loosening process. Do not apply excessive impact force to the button head cap screws. Ample seating torque can be applied by the T-handled Allen wrench and normal arm strength levels. Excessive impact force can cause the T-handled Allen wrench to slip out of the button head cap screw, resulting in property damage and/or personal injury.



CAUTION

Do not substitute a different fastener type for the button head cap screw configuration. The button head configuration was chosen for operational considerations. The use of other fastener types can increase the potential for property damage and/or personal injury.



DANGER

BLADES ARE EXTREMELY SHARP. CONTACT WITH THE BLADE CAN RESULT IN PROPERTY DAMAGE AND/OR PERSONAL INJURY. BLADES ARE PROVIDED WITH A PROTECTIVE COVER OVER THE CUTTING EDGE. EXERCISE EXTREME CAUTION WHEN REMOVING AND/OR REINSTALLING THE PROTECTIVE COVER. STORE THE BLADE WITH THE PROTECTIVE COVER PROPERLY INSTALLED TO MINIMIZE THE POTENTIAL FOR BLADE DAMAGE AND/OR PERSONAL INJURY.

8) Return the Bon Floor Stripper to its normal operating position.

9) Determine that the ON/OFF switch located on the operator handle is in the OFF position. If the Bon Floor Stripper is to be used immediately, then reconnect the extension cord or Bon Floor Stripper to the power source.



DANGER

UNEXPECTED MACHINE START UP CAN RESULT IN PROPERTY DAMAGE AND/OR PERSONAL INJURY.

REMOVING THE BLADE OR CERAMIC TILE RIPPER ATTACHMENT FROM THE Bon Floor Stripper.

Tools Required: 1 each, 5/32 inch T-handled Allen wrench provided with the machine.



DANGER

WHEN INSTALLING OR REMOVING A BLADE OR THE CERAMIC TILE RIPPER ATTACHMENT TO/FROM THE BON FLOOR STRIPPER, ALWAYS WEAR THE APPROPRIATE SAFETY EYEWEAR, GLOVES, LEATHER SHOES AND

LONG PANTS TO MAXIMIZE PERSONAL PROTECTION FROM THE SHARP EDGE(S). IMPROPER CONTACT WITH A SHARP EDGE CAN RESULT IN PROPERTY DAMAGE AND/OR PERSONAL INJURY.

1) Properly disconnect the extension cord or the Bon Floor Stripper from the power source.

2) To place the operator handle in the work position, move the handle upright so that the ball-detent pins can be inserted through the operator handle and main frame. Determine the ball-detent pins are inserted through the operator handle and main frame to fully expose the ball detent. FIGURE 15



FIGURE 15



DANGER

THE BALL DETENT MUST BE FULLY EXPOSED AGAINST THE MAIN FRAME TO PROVIDE THE PROPER PIN RETAINING FORCE. AN IMPROPER PIN RETAINING CONFIGURATION CAN RESULT IN UNEXPECTED OPERATOR HANDLE MOVEMENT. THIS OCCURRENCE CAN RESULT IN PROPERTY DAMAGE AND/OR PERSONAL INJURY.

3) Loosen the threaded handle knobs and extend the operator handle out until it stops against the threaded studs. Retighten the knobs. FIGURE 16.



CAUTION

Improper knob tension and/or improperly securing the operator handle to the main frame can result in an unstable platform configuration. An unstable platform configuration can result in property damage and/or personal injury.



FIGURE 16

4) Tilt the Bon Floor Stripper back until the operator handle comes in contact with the surface. The Bon Floor Stripper may not be in a stable position in this configuration. To minimize the possibility of property damage and/or personal injury, properly secure an appropriate weight to the handle for added stability. Other means can also be utilized to support the frame and provide proper machine stability. Appropriate wheel chocks are also recommended. FIGURE 17.



FIGURE 17

 **DANGER**

EXERCISE EXTREME CAUTION WHEN WORKING NEAR OR UNDER THE RIP-R-STRIPPER WITH THE OPERATOR HANDLE TILTED BACK IN THE SERVICE POSITION. IF THE BON FLOOR STRIPPER IS NOT POSITIONED IN A STABLE CONFIGURATION, WITH ADEQUATE COUNTERWEIGHT PROPERLY SECURED, UNEXPECTED MOVEMENT CAN ALLOW THE MACHINE TO FALL BACK TO THE WORK SURFACE. THE RESULT CAN BE PROPERTY DAMAGE AND/OR PERSONAL INJURY.

5) Reinstall the protective blade cover. Exercise extreme caution when removing and/or reinstalling the protective cover. Use the T-handled Allen wrench to loosen the button head cap screws which secure the blade between the fence plate and exciter plate. Remove the blade and store in an appropriate location. Use the T-handled Allen wrench to tighten the button head cap screws. Keep the button head cap screws tight to minimize becoming lost.

6) The removal of the ceramic tile ripper attachment is similar to that of a blade with the exception that the fence plate is reinstalled to the exciter plate. Follow the same tightening procedure as with a blade.



CAUTION

For all blades and the ceramic tile ripper attachment, tighten the button head cap screws only with the T-handled Allen wrench provided. Do not utilize another wrench type and/or configuration. The T-handled Allen wrench was chosen to place body parts a practical distance from the blade during the fastener tightening and loosening process. Do not apply excessive impact force to the button head cap screws. Ample seating torque can be applied by the T-handled Allen wrench. Excessive impact force can cause the T-handled Allen wrench to slip out of the button head cap screw, resulting in property damage and/or personal injury.



CAUTION

Do not substitute a different fastener type for the button head cap screw configuration.

The button head configuration was chosen for operational considerations. The use of other fastener types can increase the potential for property damage and/or personal injury.



DANGER

BLADES ARE EXTREMELY SHARP. CONTACT WITH THE BLADE CAN RESULT IN PROPERTY DAMAGE AND/OR PERSONAL INJURY. BLADES ARE PROVIDED WITH A PROTECTIVE COVER OVER THE CUTTING EDGE. EXERCISE EXTREME CAUTION WHEN REMOVING AND/OR REINSTALLING THE PROTECTIVE COVER. STORE THE BLADE WITH THE PROTECTIVE COVER PROPERLY INSTALLED TO MINIMIZE THE POTENTIAL FOR BLADE DAMAGE AND/OR PERSONAL INJURY.

7) Return the Bon Floor Stripper to its normal operating position.

8) Determine that the ON/OFF switch located on the operator handle is in the OFF position. If the Bon Floor Stripper is to be used immediately, then reconnect the extension cord or Bon Floor Stripper to the power source.



DANGER

UNEXPECTED MACHINE START UP CAN RESULT IN PROPERTY DAMAGE AND/OR PERSONAL INJURY.

Operation

OPERATIONAL DISCLAIMER.

THE MANUFACTURER OF THE BON FLOOR STRIPPER MAKES NO WARRANTY OR GUARANTEE THAT IT IS MERCHANTABLE AND/OR SUITABLE FOR ANY SPECIFIC JOB APPLICATION AND THAT IT WILL HAVE THE CAPABILITY AND POWER REQUIRED TO REMOVE ANY SPECIFIC COVERING FROM ANY SPECIFIC WORK SURFACE.

CALIFORNIA PROPOSITION 65
DISCLAIMER.

DANGER

THE DUSTS/BYPRODUCTS FROM THE COVERING REMOVAL PROCESS ASSOCIATED WITH THE OPERATION OF THE Bon Floor Stripper CAN CONTAIN CHEMICALS KNOWN TO CAUSE CANCER, BIRTH DEFECTS, OR OTHER REPRODUCTIVE HARM.

INFORMATION RELATIVE TO MINIMUM COMPONENT STANDARDS FOR THE OPERATION OF THE BON FLOOR STRIPPER.

For operational safety and overall productivity considerations, it is required that specific Bon Floor Stripper components meet minimum acceptable operational standards BEFORE utilization:

1) Operator handle be properly mounted to the main frame, with factory supplied ball-detent type retaining pins that properly secure the handle to the main frame while in the work position.

2) The operator handle is equipped with properly fitting handle grips of sufficient integrity to allow for proper job function as outlined within this manual. Loose fitting handle grips or grips without full end caps are not permitted.

3) An ON/OFF motor switch that allows it to perform its intended job function as outlined within this manual. Replace any damaged ON/OFF motor switch with a factory approved replacement part only.

4) An extension cord and GFI that allows this accessory to perform its intended job function as outlined within this manual. Replace any damaged extension cord or GFI with a factory approved replacement part only.

5) Exciter plate elastomeric rubber mounts which allow them to perform their intended job function as outlined within this manual. Do not operate the BON FLOOR STRIPPER without the correct number of exciter plate elastomeric rubber mounts. Do not operate the Bon Floor Stripper with a damaged and/or improperly secured rubber mount. Replace any damaged rubber mount with a factory approved replacement part only.

6) Blade(s) and/or ceramic tile ripper attachment of proper structural integrity (void of cracks, etc), straightness, sharpness, etc which are retained by the

proper fasteners. Replace worn or damaged blades, fasteners and the ceramic tile ripper attachment with a factory approved replacement part only.

7) All safety decals, Operator Manual and operational information decals (including the applicable Quik Tips information) must be in proper and readable condition. Replace any missing or damaged safety decal, Operator Manual and/or information decal with a factory approved replacement part only.

TRANSPORTING THE BON FLOOR STRIPPER.

The Bon Floor Stripper has an operational weight that prohibits one person from loading and/or unloading it alone by conventional, physical efforts.

DANGER

DO NOT ATTEMPT TO LIFT THE RIP-R-STRIPPER UP INTO A TRANSPORTATION VEHICLE WITH THE USE OF ONE PERSON ALONE. DO NOT ATTEMPT TO LOWER THE BON FLOOR STRIPPER FROM A TRANSPORTATION VEHICLE WITH THE USE OF ONE PERSON ALONE. LIFT AND/OR LOWER THE Bon Floor Stripper ONLY BY THE USE OF A POWER TAILGATE UNIT, A SUITABLE HOIST UNIT OF PROPER CAPACITY AND/OR CONFIGURATION OR BY THE USE OF A PROPER QUANTITY OF PERSONNEL IN PROPER PHYSICAL/MENTAL CONDITION.

1) The Bon Floor Stripper can be hoisted by a mechanical device incorporating a chain and suitable attachment device to the lifting bail area located behind the electric motor. FIGURE 18. This location may not always locate the exact position of the center of gravity for the Bon Floor Stripper. Lifting handles are also provided on both sides of the main frame. These handles can be utilized by personnel whenever lifting/lowering the Bon Floor Stripper. FIGURE 19.

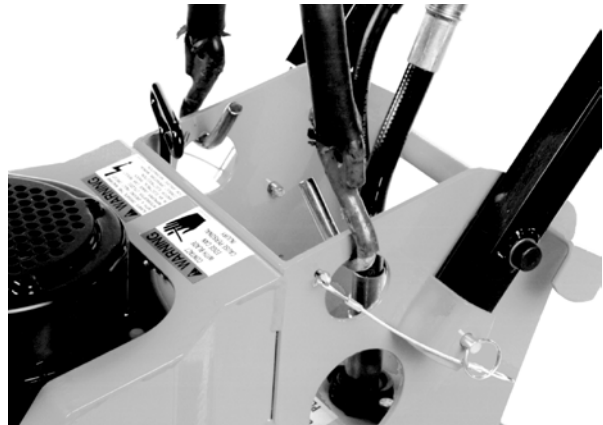

FIGURE 18

DANGER

EXERCISE EXTREME CAUTION WHEN UTILIZING A MECHANICAL DEVICE FOR LIFTING THE Bon Floor Stripper. UTILIZE THE MECHANICAL DEVICE IN ACCORDANCE TO BOTH ITS DESIGNED STATIC AND DYNAMIC LOADING ENVELOPES. DO NOT UTILIZE THE MECHANICAL DEVICE UNTIL THIS INFORMATION IS PROPERLY KNOWN AND UNDERSTOOD BY ALL APPLICABLE PERSONNEL. FAILURE TO PROPERLY UTILIZE THE MECHANICAL DEVICE CAN RESULT IN PROPERTY DAMAGE AND/OR PERSONAL INJURY.

CAUTION

Do not drop the Bon Floor Stripper directly upon the exciter plate. Direct impact against the exciter plate can result in damage to components including the plate, elastomeric rubber mounts, electric motor shaft, bearings, etc.



FIGURE 19

2) To minimize the possibility of damage to the Bon Floor Stripper, always transport in its normal, upright position. All equipment must be secured in/on vehicles with suitable strapping or tie-downs. Personnel should not be transported in the same compartment as equipment. Consult applicable OSHA and transportation regulations (local, State and Federal) for the proper transportation of the Bon Floor Stripper.

3) Do not transport the Bon Floor Stripper with a blade or the ceramic tile ripper attachment attached to the main frame in the following configurations:

- a) To and from the job site.
- b) For longer distances while being repositioned on the job site.
- c) When traversing up and down stairways.
- d) While performing maintenance and/or repairs.
- e) Lifting up/into or/down from a transporting vehicle.

Remove the blade or ceramic tile ripper attachment according to the procedures as outlined in this manual for the above listed configurations.



DANGER

LIFTING, LOWERING AND TRANSPORTING THE Bon Floor Stripper WITH A BLADE OR CERAMIC TILE RIPPER ATTACHMENT INSTALLED CAN RESULT IN PROPERTY DAMAGE AND/OR PERSONAL INJURY.

4) When transporting to and from the job site, block the bottom of the main frame to prevent direct impact blows against the exciter plate. This procedure will reduce impact loads directly to the elastomeric rubber mounts, minimize their deflection and increase service life.

ADJUSTING THE OPERATOR HANDLE HEIGHT.

The Bon Floor Stripper incorporates a handle that can be adjusted to compensate for variances in operator height. Handle height can be infinitely varied between the stop limits. No external tools are required. Correct handle height can increase overall machine productivity and reduce operator fatigue.

1) Loosen the handle knobs located at the rear of the handle. Extend the knobs out approximately 1/2 inch (13 mm). FIGURE 20.



FIGURE 20

2) Position the operator handle grips at a height convenient to the specific operator. In most configurations, the operator handle grips will be at approximately waist level.

3) Tighten the handle knobs finger tight. Determine the adjustable section of the operator handle is properly secured tight against the fixed section.



CAUTION

Improper knob tension and/or improperly securing the operator handle to the main frame can result in an unstable platform configuration. An unstable platform

configuration can result in property damage and/or personal injury.

DANGER

DETERMINE THE THREADED STUDS ARE PROPERLY SEATED AGAINST THE SLIDING SECTION OF THE OPERATOR HANDLE. THE ADJUSTABLE SECTION MUST BE FIRMLY SECURED TIGHT AGAINST THE FIXED SECTION OF THE OPERATOR HANDLE. IMPROPERLY SECURED STUDS CAN RESULT IN INADVERTENT OPERATOR HANDLE MOVEMENT AND/OR SEPARATION, RESULTING IN PROPERTY DAMAGE AND/OR PERSONAL INJURY.

STARTING THE BON FLOOR STRIPPER ON THE JOB SITE.

- 1) Position the Bon Floor Stripper on a flat and level surface of firm foundation.
- 2) Install a blade or the ceramic tile ripper attachment per the procedures as outlined in this manual.
- 3) Determine that the ON/OFF switch located on the operator handle is in the OFF position.

DANGER

UNEXPECTED MACHINE START UP CAN RESULT IN PROPERTY DAMAGE AND/OR PERSONAL INJURY.

- 4) The Bon Floor Stripper is designed to operate from a clean, 15 ampere, 115 VAC, 60 Hz, nominal power source. A clean power source refers to the amperage available from the individual electrical circuit selected. Additional electrical products already utilizing the same circuit will reduce the available amperage, and can result in starting and operational difficulties.

CAUTION

Operating the Bon Floor Stripper from a power source of improper voltage and/or amperage will result in unrepairable damage to the electric motor and related controls.

- 5) Providing proper voltage and amperage levels to the electric motor is essential to obtain maximum productivity and service life. Low voltage and amperage levels will cause the motor to overheat. The motor is equipped with an automatic thermal protection device that will stop it before major internal damage can result. After the motor has cooled to an acceptable temperature level, the switch must be manually activated to restart. FIGURE 21.



FIGURE 21

- 6) The Bon Floor Stripper utilizes a factory supplied extension cord equipped with an integral GFI device. The GFI device is intended to protect both the operator and electric motor in the event a ground fault is developed during operation. The extension cord is 37 foot (11 m) long, fabricated from 12 AWG wire and incorporates a NEMA 5-15P plug and a NEMA L5-15R twist lock type receptacle. The twist lock feature allows the extension cord to be pulled by the Bon Floor Stripper without becoming disconnected.

DANGER

BEFORE USE, PROPERLY INSPECT THE EXTENSION CORD AND WIRING DEVICES FOR STRUCTURAL INTEGRITY. DO NOT UTILIZE A CORD WITH A WORN OR CUT OUTER JACKET MATERIAL. DO NOT UTILIZE A CORD WITH EXPOSED INNER WIRES OR INSULATION MATERIAL. DO NOT UTILIZE A CORD THAT HAS BEEN REPAIRED WITH ELECTRICAL TAPE. DO NOT UTILIZE A CORD WITH A CRACKED AND/OR DAMAGED GFI CASE. USE OF AN EXTENSION CORD OF IMPROPER STRUCTURAL INTEGRITY AND/OR DAMAGED GFI CAN RESULT IN PROPERTY

DAMAGE AND/OR PERSONAL INJURY.**⚠ DANGER**

ALL ELECTRICAL WIRING, INCLUDING EXTENSION CORD GAUGE SIZE AND/OR LENGTH, MUST BE INSTALLED AND/OR APPROVED IN ACCORDANCE TO LOCAL ELECTRICAL CODES AND PRACTICES. AN IMPROPER WIRING INSTALLATION CAN RESULT IN PROPERTY DAMAGE AND/OR PERSONAL INJURY.

7) Determine that the power source receptacle to be utilized is properly grounded. This can be accomplished with proper testing equipment and procedures. If there are any questions regarding the suitability of a specific power receptacle, contact your dealer or our Customer Service Department for assistance **BEFORE** utilizing the Bon Floor Stripper. There is no charge for this service. A qualified electrician may need to be consulted.

8) If additional extension cord length is required for a specific job application, an additional extension cord can be utilized in conjunction with an external GFI. Plug the receptacle of the additional extension cord into the factory supplied GFI. Plug the ground fault circuit interrupter into a separate power source receptacle. Connect the extension cord plug into the external GFI. This configuration will allow any fault over the length of a defective extension cord to be indicated. Extension cord gauge size and length must conform to National Electric Code standards.

⚠ DANGER

FOR MAXIMUM PROTECTION AGAINST A FAULT, ALWAYS CONFIGURE A GROUND FAULT CIRCUIT INTERRUPTER TO BE PLUGGED INTO THE POWER SOURCE RECEPTACLE. A CONFIGURATION WITH THE GROUND FAULT CIRCUIT INTERRUPTER PLACED BETWEEN THE RIPPER-STRIPPER AND THE POWER SOURCE RECEPTACLE WILL NOT AFFORD MAXIMUM PROTECTION AGAINST A POTENTIAL FAULT.

9) Couple the NEMA L5-15R receptacle of the factory supplied extension cord and the NEMA L5-15P plug located on the Bon Floor Stripper together. Twist to

lock. **FIGURE 22.** Connect the GFI to the power source receptacle. Determine that the reset switch is in its proper position to activate the GFI.

10) Grasp the operator handle with firm gripping. When starting the electric motor, apply a down force directly to the operator handle to help reduce the amount of static machine weight against the work surface. The blade or ceramic tile ripper attachment should remain in contact with the surface. Turn the ON/OFF switch to the ON position. Reduce the amount of applied down force on the operator handle as the electric motor attains its operational speed.



FIGURE 22

11) The Bon Floor Stripper is not equipped with a centrifugal clutch assembly. The electric motor is directly coupled to the exciter plate. The exciter plate will begin to move when the electric motor starts.

⚠ DANGER

AS SOON AS THE ELECTRIC MOTOR HAS STARTED, THE OPERATOR MUST BE IN A POSITION TO ASSUME DIRECT AND FULL CONTROL OF THE BON FLOOR STRIPPER. FAILURE TO ASSUME DIRECT AND FULL CONTROL CAN RESULT IN PROPERTY DAMAGE AND/OR PERSONAL INJURY.

12) The Bon Floor Stripper is stopped by moving the ON/OFF switch located on the operator handle to the OFF position. For safety considerations, it is also recommended that the extension cord be

disconnected from both the Bon Floor Stripper and power source receptacle whenever the Bon Floor Stripper is not in use on the job site.

DANGER

IF THE Bon Floor Stripper IS EQUIPPED WITH A TOGGLE TYPE ON/OFF SWITCH THE MOTOR CAN RESTART IF THE ON/OFF SWITCH IS NOT MOVED TO THE OFF POSITION WHEN THE POWER SOURCE LOOSES POWER AND THEN BECOMES RE-ENERGIZED.

13) If the Bon Floor Stripper is equipped with a magnetic start (push button) type ON/OFF switch, the motor will not restart if the power source loses power and then becomes re-energized unless the OFF button is first pushed.

CAUTION

If the Bon Floor Stripper and/or an individual component/accessory does not appear to be functioning properly, STOP and do not further operate the Bon Floor Stripper until the proper corrective action has been completed. If there are any questions regarding the proper operation of the RIP-R-STRIPPER, contact the Customer Service Department BEFORE further utilization. There is no charge for this service.

OPERATING THE Bon Floor Stripper ON THE JOB SITE.

DANGER

THE COVERINGS REMOVAL PROCESS CAN PRODUCE EXCESSIVE NOISE, VIBRATION AND FLYING DEBRIS. ALL OPERATORS AND WORK PERSONNEL IN THE VICINITY OF THE Bon Floor Stripper MUST WEAR APPROPRIATE SAFETY EYE WEAR AND HEARING PROTECTION DEVICES. OTHER SAFETY APPAREL AND/OR PROCEDURES, DEEMED NECESSARY BY SUPERVISORY PERSONNEL MUST ALSO BE WORN AND/OR PRACTICED BY ALL APPROPRIATE PERSONNEL.

1) The Bon Floor Stripper utilizes an offset weight

design (termed the exciter) that moves the blade or ceramic tile ripper attachment with a random orbit oscillation. This design configuration substantially enhances machine control and reduces fatigue as long as the blade or ceramic tile ripper attachment does not come in direct contact with a protruding obstruction from the floor. Direct contact with such an obstruction can result in rapid and jerky directional movement of the machine. This occurrence can lead to loss of machine control, property damage and/or personal injury. In most operating situations, direct contact with a protruding obstruction from the work surface will, at a minimum, result in damage to the blade and/or ceramic tile ripper attachment.

DANGER

EXERCISE EXTREME CAUTION WHEN OPERATING THE Bon Floor Stripper IN THE VICINITY OF ANCHOR BOLTS, PIPES, COLUMNS, OPENINGS, PROTRUDING NAIL HEADS, LARGE CRACKS, UTILITY OUTLETS OR ANY OBJECT PROTRUDING FROM THE WORK SURFACE. CONTACT WITH SUCH OBJECTS CAN LEAD TO LOSS OF MACHINE CONTROL, RESULTING IN PROPERTY DAMAGE AND/OR PERSONAL INJURY.

DANGER

ALWAYS MAINTAIN PROPER CONTROL OF THE Bon Floor Stripper. IF AN OPERATOR LOOSES CONTROL OF THE MACHINE, A "RUNAWAY" Bon Floor Stripper CAN RESULT IN PROPERTY DAMAGE AND/OR PERSONAL INJURY. BECAUSE OF THE UNIQUE OPERATING CHARACTERISTICS OF THE Bon Floor Stripper, THERE IS NO PROVISION FOR THE ELECTRIC MOTOR TO AUTOMATICALLY STOP IF THE OPERATOR FAILS TO MAINTAIN PROPER CONTROL.

DANGER

WHEN OPERATING THE Bon Floor Stripper ON ABOVE GROUND FLOOR LEVELS, EXERCISE EXTREME CAUTION TO PREVENT LOSS OF CONTROL THAT COULD ALLOW THE MACHINE AND/OR OPERATOR TO FALL DOWN TO LOWER LEVELS. SUCH AN OCCURRENCE CAN

RESULT IN PROPERTY DAMAGE AND/OR PERSONAL INJURY. WHEN WALKING BACKWARDS DURING THE COVERING REMOVAL PROCESS, BE AWARE OF DROP OFFS AND OBSTRUCTIONS.

2) Productivity rates with the various blade and/or attachments can be increased with the addition of external weight being applied to the front of the machine. FIGURE 23. Each external weight block weighs 14 lbs (6.3 kg). Maximum allowable external weight permits the use of three blocks or 42 lbs (19 kg). Exceeding this figure can result in permanent structural damage to the Bon Floor Stripper. The additional external weight blocks can be secured to the machine with the use of longer length carriage bolts. FIGURE 24.

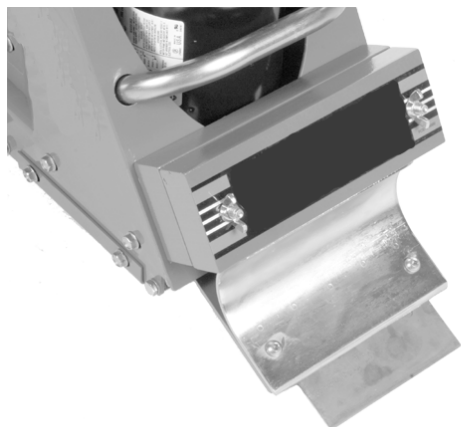

FIGURE 23

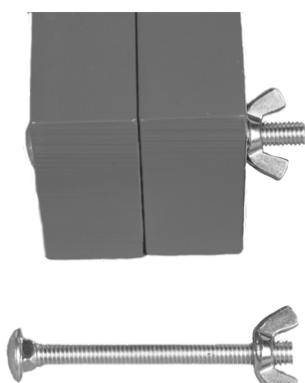

FIGURE 24

⚠ DANGER

DO NOT OPERATE THE Bon Floor Stripper WITHOUT ALL EXTERNAL WEIGHT PROPERLY SECURED TO THE MAIN FRAME. A SUDDEN CHANGE IN MOVEMENT OR DIRECTION CAN ALLOW THE UNSECURED WEIGHT TO FALL OFF THE Bon Floor Stripper, RESULTING IN LOSS OF MACHINE CONTROL, PROPERTY DAMAGE AND/OR PERSONAL INJURY. THIS PROCEDURE IS ESPECIALLY IMPORTANT WHEN OPERATING THE Bon Floor Stripper ON FLOORS AND/OR SURFACES ABOVE GROUND LEVEL.

3) Proper operator posture and stance will enhance productivity rates and minimize fatigue. Adjust the operator handle height to place the handle grips at approximately waist level. Keep the upper body as vertical as possible. This procedure will help to maximize leverage and minimize back related stress. Keep feet a comfortable distance apart to help provide stability and locomotion force. A proper operator position is depicted in FIGURE 25. Improper operator positions are depicted in FIGURES 26 and 27. The proper and improper operator positions depicted in this manual are not all inclusive.



FIGURE 25



FIGURE 26



FIGURE 27

4) The wide variety of potential covering materials along with the corresponding variety of job site environments, makes it impossible to develop a standardized operating procedure for the Bon Floor Stripper. Use of the Bon Floor Stripper will require constant trial and error testing until satisfactory results are achieved. Experience, gained over time, along with good common sense will help minimize the amount of necessary testing. Many factors will directly affect the operating parameters and/or techniques utilized for a specialized job application. Some of these factors include:

a) Work surface material yield and tensile values. As a general rule, these values will determine material removal rate per unit of time. Materials with high yield and tensile values will characteristically resist/limit penetration. For such materials, the accepted procedure is to decrease blade width and determine optimum blade angle relative to the floor surface. This will require increasing or decreasing the blade angle

with the Blade Control System. Other added benefits to this technique are decreased vibration, less operator fatigue and increased component service life.

b) Higher material removal rates can sometimes be achieved by making a series of passes 90 degrees to each other to form a waffle like pattern. This technique is especially useful when removing deeper accumulations of rubber type materials, material residues and dirt debris from industrial floors.

c) The covering removal process can be extremely abrasive to the blade cutting edge. Blades can be sharpened in the field by the use of the metal file stored on the fixed section of the operator handle. Use of the file in the field will not duplicate the original blade manufacturing process, but can significantly increase overall productivity rates versus the continued use of a dull blade. Remove the blade from the Bon Floor Stripper per the procedures outlined in this manual. Clamp the blade in a suitable vice. Use the file to sharpen the blade with a procedure similar to that of sharpening a rotary lawnmower blade. FIGURE 28.



FIGURE 28



DANGER

EXERCISE EXTREME CAUTION WHEN SHARPENING THE BLADE. CLAMP THE BLADE FIRMLY IN THE VICE. REMAIN CLEAR OF THE CUTTING EDGE DURING THE SHARPENING PROCESS. IMPROPER CONTACT WITH THE BLADE CAN RESULT IN PROPERTY DAMAGE AND/OR PERSONAL INJURY.

5) The coverings removal process on many work surface materials can produce sparks, dust and other foreign particle contamination. Many covering materials, adhesives and/or mastics can contain asbestos and other chemicals that are known to cause physical harm and/or affect the environment. These types of materials need to be properly identified, contained and disposed of according to established OSHA, EPA and other rules and regulations.

DANGER

SPARKS PRODUCED BY THE ACTIONS OF BLADE AND/OR CERAMIC TILE RIPPER ATTACHMENT AGAINST THE WORK SURFACE (FOR EXAMPLE: STRIKING ANCHOR BOLTS) CAN RESULT IN A FIRE AND/OR EXPLOSION. THIS OCCURRENCE CAN RESULT IN PROPERTY DAMAGE AND/OR PERSONAL INJURY.

DANGER

THE CREATION OF DUST AND OTHER FOREIGN PARTICLE CONTAMINATION FROM THE COVERING REMOVAL PROCESS CAN RESULT IN PROPERTY DAMAGE AND/OR PERSONAL INJURY. FOR SUCH OPERATING CONDITIONS, ALWAYS WEAR A NIOSH/MSHA APPROVED DUST/MIST RESPIRATOR AND APPROPRIATE SAFETY RELATED APPAREL. CONSULT APPLICABLE OSHA REGULATIONS FOR SPECIFIC INFORMATION.

6) Dust and other particle contamination can be controlled by the use of an appropriate industrial type vacuum system to remove/control dust and other particle contamination from the work surface.

DANGER

ALWAYS UTILIZE A VACUUM SYSTEM TO OPERATE WITHIN THE SPECIFIC JOB SITE REQUIREMENT. DUST MATERIAL CAN MEET CLASS II OR CLASS III SPECIFICATIONS OF THE NATIONAL ELECTRIC CODE® FOR HAZARDOUS

LOCATION CLASSIFICATIONS. CONSIDERATION MUST ALSO BE GIVEN TO THE CREATION OF HAZARDOUS TYPE MATERIALS REQUIRING SPECIFIC DISPOSAL PROCEDURES. DETERMINE THAT THE VACUUM SYSTEM IS PROPERLY DESIGNED TO OPERATE WITHIN THESE ATMOSPHERES. CONSULT CURRENT NATIONAL ELECTRIC CODE®, OSHA AND ENVIRONMENTAL PROTECTION AGENCY REGULATIONS FOR SPECIFIC INFORMATION.

7) Water applied to the work surface is not normally utilized to control dust and other particle contamination. Water, and/or other conductive materials, should be removed from the work surface by an industry approved and/or accepted practice BEFORE utilizing the Bon Floor Stripper to remove the covering material. The presence of water and/or any other conductive material on the work surface can substantially increase the potential electrocution concern for the operator and/or associated work personnel.

DANGER

WATER OR OTHER CONDUCTIVE MATERIALS DEPOSITED ON THE WORK SURFACE INCREASES THE ELECTROCUTION POTENTIAL FOR THE OPERATOR AND/OR ASSOCIATED WORK PERSONNEL. DETERMINE THE BON FLOOR STRIPPER IS PROPERLY GROUND-ED (NO FAULTS), THE EXTENSION CORD IS FREE OF CUTS, ABRASIONS, EXPOSED CABLE STRANDS AND THAT THE GFI PROPERLY FUNCTIONS TO ELIMINATE FAULT CONCERNS. IMPROPER MACHINE GROUNDING, EXTENSION CORDS AND/OR GFI CAN RESULT IN PROPERTY DAMAGE AND/OR PERSONAL INJURY.

8) Normal usage of the Bon Floor Stripper will allow the build-up and accumulation of work surface materials on the surfaces. It is highly recommended that both the interior and exterior surfaces be properly cleaned after the completion of each use.

CAUTION

Failure to properly clean the interior surfaces

of the Bon Floor Stripper can result in dried material build-up and accumulation directly affecting bearing service life.



DANGER

EXERCISE EXTREME CAUTION WHEN UTILIZING ANY SOLVENT TO REMOVE ACCUMULATED MATERIALS FROM THE SURFACES OF THE MACHINE AND RELATED COMPONENTS. MANY SOLVENTS ARE FLAMMABLE. DO NOT SMOKE OR INTRODUCE FLAME IN THE WORK AREA. PROVIDE ADEQUATE VENTILATION AND WEAR PROPER SAFETY APPAREL.



DANGER

PROPERLY DISPOSE OF ALL ACCUMULATED MATERIALS PER OSHA AND ENVIRONMENTAL PROTECTION AGENCY CODES AND REGULATIONS. MANY ACCUMULATED MATERIALS CAN BE CLASSIFIED AS HAZARDOUS AND REQUIRE PROPER DISPOSAL PROCEDURES. CONTACT THE APPLICABLE GOVERNMENT AND/OR PRIVATE AGENCIES FOR SPECIFIC INFORMATION.

9) When the covering removal process creates a considerable amount of loose material on the work surface, it can become almost impossible to determine proper material removal depths and the extent of work already accomplished. The problem can be compounded if a vacuum system is not utilized. Loose material should be removed by sweeping or other, appropriate processes and the Bon Floor Stripper utilized until conditions again warrant removing the accumulated material.

STOPPING THE BON FLOOR STRIPPER ON THE JOBSITE.

1) Stopping the Bon Floor Stripper is accomplished by moving the ON/OFF switch located on the operator handle to the OFF position. For safety considerations, it is also recommended that the extension cord be disconnected from both the Bon Floor Stripper and electric power source whenever the Bon Floor Stripper is not in use on the job site.

OPERATIONAL PARAMETERS AND TECHNIQUES FOR THE Bon Floor Stripper.

- 1) The specific type and/or density of adhesives and mastics which bond coverings to the work surface can directly affect removal rates. Many adhesives or mastics remain flexible in the fully cured state. These types of materials are usually darker or black in color. The adhesives and mastics which become dried in the fully cured state are usually yellowish or opaque in color. These types of materials will usually require less effort to remove than the dark types which remain flexible even when cured.
- 2) As a general rule, the lower the adhesive or mastic density (amount) utilized to adhere the covering to the work surface, the lower the force required to "shear" through the bond and thus, the greater the covering removal rate.
- 3) As a general rule, the thicker the adhesive or mastic utilized to adhere the covering to the work surface, the greater the force required to "shear" through the bond and thus, the lower the covering removal rate.
- 4) The Blade Control System is designed to adjust blade angle relative to the work surface without first stopping the machine to adjust mechanical linkages or bend over to operate a crank lever system. The Control System features a crank lever located on the operator console. FIGURE 29. Crank the lever clockwise to decrease the blade angle. Turn the crank lever counterclockwise to increase the blade angle.



FIGURE 29

5) Typically, adhesive/mastic densities or thickness change on the job site usually as a result of application rates on the work surface. This, in turn directly affects bond densities and thickness. As these factors change, the blade angle can be adjusted with the Back Saver™ Blade Control System to help optimize covering removal rates.

6) Keep the extension cord free and clear the the main frame area and orbiting blade/ceramic tile ripper attachment while the Bon Floor Stripper is in operation. Contact with the blade can damage the extension cord and create a potential electrocution concern. In the event of damage, replace the extension cord with a factory approved replacement part only.

DANGER

KEEP THE EXTENSION CORD FREE AND CLEAR OF THE MAIN FRAME AND BLADE AREA WHILE THE Bon Floor Stripper IS IN OPERATION. CONTACT WITH THE MAIN FRAME AND BLADE AREA CAN RESULT IN PROPERTY DAMAGE AND/OR PERSONAL INJURY.

DANGER

IN THE EVENT THE EXTENSION CORD BECOMES ENTANGLED ABOUT THE Bon Floor Stripper AND/OR THE OPERATOR, TURN THE ELECTRIC MOTOR ON/OFF SWITCH TO THE OFF POSITION. FAILURE TO PROPERLY STOP THE Bon Floor Stripper IN THIS OPERATING CONFIGURATION CAN RESULT IN PROPERTY DAMAGE AND/OR PERSONAL INJURY. DETERMINE THE EXTENSION CORD AND GFI ARE IN PROPER CONDITION TO CONTINUE OPERATION. REPLACE ANY DAMAGED COMPONENT WITH A FACTORY APPROVED REPLACEMENT PART ONLY.

DANGER

DISCONNECT THE EXTENSION CORD FROM THE Bon Floor Stripper WHEN TRAVERSING UP AND DOWN STAIRWAYS. AN IMPROPERLY STORED/CONNECTED EXTENSION CORD CAN ENTRAP AND/OR ENTANGLE PERSONNEL, RESULTING IN PROPERTY DAMAGE AND/OR PERSONAL INJURY.

7) Scoring blades are available to remove covering material such as rubber-backed carpet and linoleum from concrete and wood surfaces. The vertical ends of the scoring blade are designed to shear the covering and remove it in various widths as determined by the overall blade width. FIGURE 30.



FIGURE 30

CAUTION

Do not operate the Bon Floor Stripper with the vertical ends of the scoring blade facing down toward the work surface. In this configuration, damage to the work surface can result.

8) Part Number FCS16-1900 Blade can be mounted to the Bon Floor Stripper in the offset configuration to allow coverings to be removed from under the kick panel areas of cabinets and other, inaccessible locations. A stiffener is included with this blade as a standard accessory and must be mounted whenever this blade is utilized to minimize blade deflection. FIGURE 31.



FIGURE 31



CAUTION

Do not operate Part Number FCS16-1900 Blade without the additional stiffener properly mounted to the blade. Improper use of this blade without the additional stiffener can result in property damage and/or personal injury.

Service

PREVENTATIVE MAINTENANCE CHECK LIST.

The normal operation of the Bon Floor Stripper produces extreme dirt and dust, along with levels of random vibration. Before operating the BON FLOOR STRIPPER, the following service list should be accomplished. This list is for reference only and is not intended to be all inclusive. Other topic areas can be added at the discretion of the owner(s) and/or operator(s):



DANGER

DISCONNECT THE BON FLOOR STRIPPER FROM THE EXTENSION CORD AND/OR POWER SOURCE RECEPTACLE BEFORE PERFORMING ANY SERVICE WORK OR REPAIR. TURN THE ON/OFF SWITCH TO THE OFF POSITION. FAILURE TO PROPERLY DISCONNECT THE BON FLOOR STRIPPER FROM THE

POWER SOURCE DURING THESE ACTIVITIES CAN RESULT IN PROPERTY DAMAGE AND/OR PERSONAL INJURY.

- 1) Check all fasteners for proper torque values. If a fastener requires retorquing, consult a torque chart for the proper value. Properly discard and replace any worn fastener with a factory approved, replacement part.
- 2) Check the rubber elastomeric mounts for damage and/or wear. Replace as necessary.
- 3) Check the external support bearing mounted to the motor shaft for wear and proper alignment. Many loose covering materials that accumulate in and around the support bearing area can be extremely abrasive. These materials can breach the bearing seals and significantly reduce load capacity and service life.
- 4) Determine the interior sections of the frame are free of material build-up. Such build-ups can restrict the operating process and present a potential safety hazard. Clean and remove any material build-up from the Bon Floor Stripper after each use.
- 5) Keep loose materials from accumulating around the motor cooling fan. Remove the fan shroud and clean as necessary.
- 6) Remove material accumulations from the exterior surfaces of the electric motor. The electric motor is a totally enclosed, fan cooled (TEFC) design. Keep the fan fins clear of material accumulations to enhance air flow over the motor exterior for cooling purposes.



CAUTION

Observe all applicable safety precautions for the solvent.

- 7) Lubricate the caster wheel bearings with a dry film lubricant. Use of other lubricant types can attract foreign materials and reduce bearing service life.
- 8) Zerk® type grease fittings are provided in two separate locations:
 - a) To lubricate the Back Saver™ Blade Control System jackscrew.
 - b) To lubricate the exciter bearing housing casting. The exciter unit utilizes a sealed type ball bearing. The Zerk® fitting provides lubrication for the

self-aligning feature of the bearing unit. Consult the LUBRICATION section for additional information.

Sleeve type bearings are self-lubricating and will not normally require additional lubrication during their normal service life. Ball type bearings are shielded or sealed and will not normally require additional lubrication during their normal service life.

9) Determine that all safety decals and operational information decals (including the applicable Quik Tips information) is in proper and readable condition. Replace any missing or damaged safety decal and/or information decal with a factory approved replacement part only.

10) The Bon Floor Stripper utilizes antivibration handle grips on the operator handle to enhance control and help dampen the forces experienced during the covering removal process. Determine the handle is equipped with properly fitting handle grips of sufficient integrity to allow for proper job function as outlined in this manual. Loose fitting handle grips or grips without end caps should be replaced with factory approved replacement parts only.

DANGER

DO NOT OPERATE THE Bon Floor Stripper WITHOUT PROPERLY FITTED HANDLE GRIPS OF SUFFICIENT INTEGRITY INSTALLED ON THE OPERATOR HANDLE. OPERATING THE Bon Floor Stripper WITH IMPROPER OR NO HANDLE GRIPS CAN RESULT IN PROPERTY DAMAGE AND/OR PERSONAL INJURY.

LUBRICATION REQUIREMENTS.

Parts Required:

1 each, standard grease gun filled with one of the following: ESSO Beacon 325, Shell Alvania #2,

Chevron SRI, or equivalent.

1 each, container of dry film lubricant.

1) Lubricate the caster wheel bearings with a dry film lubricant only. Dry film lubricants dry immediately upon contact. Use sparingly. Excess lubricant will attract the

fine grained, powdered materials described and directly affect bearing service life.



CAUTION

Do not lubricate the caster wheels with any lubricant other than a dry film type. Grease and many other liquid type lubricants will attract foreign material accumulations that can reduce bearing service life.

2) Zerk® type grease fittings are provided at two locations:

a) To lubricate the Back Saver™ Blade Control System jackscrew. Keep the jackscrew properly lubricated with grease to minimize friction when operating the blade control lever. Excessive lubrication will attract foreign material accumulations that can reduce jackscrew service life. FIGURE 32.

b) To lubricate the exciter bearing and bearing housing casting. The exciter utilizes a shielded type ball bearing. The Zerk® fitting provides lubrication for both the balls and self-aligning feature of the bearing unit. FIGURE 33. Grease interval will vary depending upon machine utilization rates and operating environment factors. Grease accumulation on the bearing and housing would indicate excessive lubrication.

Sleeve type bearings utilized for the operator handle are self-lubricating and will not normally require additional lubrication during their normal service life. Ball type bearings are shielded or sealed and will not normally require additional lubrication during their normal service life.

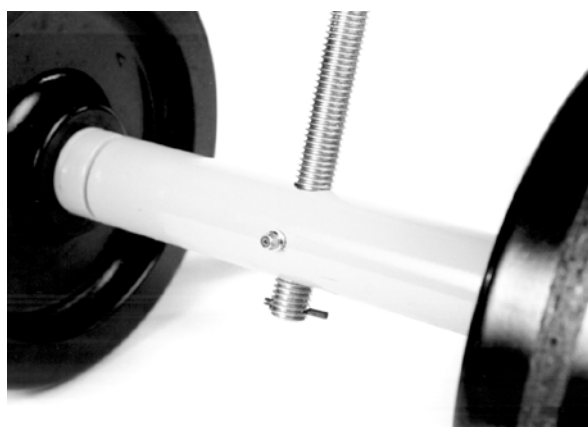

FIGURE 32

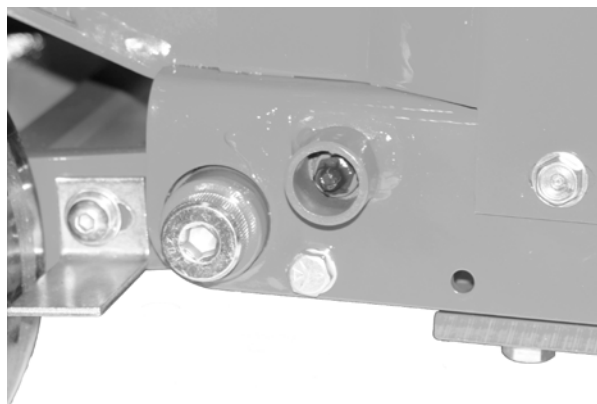

FIGURE 33

ELECTRIC MOTOR SERVICE

The electric motor is capable of operating for many years with a reasonably small amount of maintenance. Before attempting to service the motor, disconnect the Bon Floor Stripper from the power supply. Clean the motor surfaces periodically, preferably with a vacuum cleaner. Heavy accumulations of dirt and lint will result in overheating and premature failure of the motor.

The electric motor is equipped with higher capacity ball bearings and under normal service and ambient temperatures, should not require relubrication for many years. If you feel that the motor requires relubrication, contact the local representative of the motor manufacturer for specific information.

The seals utilized with the motor are intended to deliver a longer service life in a dust filled atmosphere. When replacing the seals, utilize only components meeting the original factory specifications.

Troubleshooting

ELECTRIC MOTOR.

MOTOR FAILS TO START

ON/OFF switch in the OFF position. Place switch in the ON position.

Thermal protection switch activated. Allow time for motor to cool. Motor will not start until the temperature is reduced low enough for the red switch located near the capacitor to be activated.

GFI switch activated. Push GFI button to test and rearm. Reconnect to power source.

Improper extension cord connection. Determine all connections produce a closed circuit.

No power being received from power source. Check power source for correct voltage and amperage requirements.

MOTOR LOSES POWER

Check power source for correct voltage and amperage requirements.

High operating temperatures. Clean fan blades and exterior surfaces.

OPERATIONAL PROBLEMS.

UNEVEN BLADE WEAR

Incorrect blade installation. See **INSTALLING A BLADE OR CERAMIC TILE RIPPER ATTACHMENT IN THE BON FLOOR STRIPPER.**

Damaged exciter plate. Replace plate.

Damaged elastomeric rubber mount(s). Replace mount(s).

Bent blade. Replace blade.

EXCESSIVE JUMPING ON THE WORK SURFACE

Incorrect blade or ceramic tile ripper attachment installation. See **INSTALLING A BLADE OR CERAMIC TILE RIPPER ATTACHMENT IN THE Bon Floor Stripper.**

Damaged exciter plate. Replace plate.

Damaged elastomeric rubber mount(s). Replace mount(s).

Improper blade angle. Readjust blade angle.

ACCELERATED EXCITER SHAFT BEARING WEAR AND/OR FAILURE

Misaligned and/or improperly tensioned bearing housing/mounting surfaces. Replace bearing and realign bearing housing/mounting surface.

Bent electric motor shaft. Replace motor.

Improper lubrication. See **LUBRICATION REQUIREMENTS.**

DIFFICULTY IN OPERATING THE BLADE CONTROL SYSTEM

Misaligned jackscrew bearing. Loosen and realign.

Improper lubrication. See **LUBRICATION REQUIREMENTS**.

Bent jackscrew. Replace jackscrew and flexible joint assembly.

UNEVEN COVERING MATERIAL REMOVAL

Excessive material build-up on caster wheel face surface. Remove material. Readjust wheel scraper to wheel gap setting: .03/.06 inch (.8/1.5 mm).

Excessive caster wheel bearing wear. Replace caster wheel and shoulder type cap screw.

Excessive axle shoulder type cap screw wear. Replace cap screw. Check caster wheel bearing for wear. Replace as necessary.

Damaged elastomeric rubber mount(s). Replace mount(s).

Damaged exciter plate. Replace plate.

Bent blade. Replace blade.

Storage

Proper procedure for long term storage of the Bon Floor Stripper will protect it against the effects of corrosion and damage. If the Bon Floor Stripper is not to be operated for a period of 30 days or more, proceed to store as follows:

1) Never store the Bon Floor Stripper with the blade or ceramic tile ripper attachment installed. Remove the blade or ceramic tile ripper attachment from the Bon Floor Stripper per the procedures outlined in this manual.

**CAUTION**

Do not store the Bon Floor Stripper with the blade or ceramic tile ripper attachment attached. This configuration can result in property damage and/or personal injury.

2) Clean all accumulated foreign material from the Bon Floor Stripper utilizing an appropriate safety solvent.

**CAUTION**

Observe all applicable safety precautions for the solvent.

3) Check all visible parts for wear, breakage or damage. Order any part required to make the necessary repair. This will avoid a needless delay when operating the Bon Floor Stripper at next use.

4) Apply a dry film lubricant to all exposed metal components to prevent rust.

5) Block the bottom of the main frame to prevent machine weight against the exciter plate. This procedure will reduce impact loads to the elastomeric rubber mounts, minimize deflection and increase service life.

6) Store the Bon Floor Stripper inside. If the Bon Floor Stripper must be stored outside, protect it with a suitable covering.

Specifications**FRAME**

STRUCTURE - Unitized, welded steel plate.

DRIVE SYSTEM - Random orbit, direct shaft mount.

NUMBER OF ELASTOMERIC RUBBER MOUNTS - 4.

WIDTH - 14-1/2 inches (368 mm).

WIDTH (AT OPERATOR HANDLE) - 23" (584 mm).

LENGTH (HANDLE FOLDED) 24" (610 mm).

LENGTH (OPERATING CONFIGURATION) - 34" (864 mm).

HEIGHT (HANDLE FOLDED)-23" (584 mm).

HEIGHT (MAXIMUM HANDLE EXTENSION) - 42" (1067 mm).

GENERAL

WEIGHT (WITH EXTERNAL WEIGHT LESS BLADE) 130 lbs (59 kg).

EXTERNAL WEIGHT, EACH 14 lbs (6 kg).

ELECTRIC MOTOR 3/4 hp, 1725 RPM, 10.3 full loaded amperes @ 115 VAC, 60 Hz, thermally protected. The electric motor requires a clean (no other electric products on the same circuit) 15 ampere capacity circuit to properly function. The motor can be wired to also operate from a 230 VAC, 60 Hz, power source. Contact the Customer Service Department for specific information.

NUMBER OF BLADE OSCILLATIONS 1725
PER MINUTE