

## Folded Steel Tray Wheelbarrow

- Deep, narrow (26") 18 gauge steel tray with rolled edge for maximum tray strength
- Legs are made from steel channel
- Tires equipped with zerk fitting and ball bearings
- Leg stabilizer



### SINGLE WHEEL MODELS

Part #	Handles	Tire
#11-300	Wood	16" 4-ply Knobby
#28-700	Wood	16" Flat Free
#28-702	Wood	16" 4-ply Ribbed
#28-900	Steel	16" 4-ply Knobby
#28-904	Steel	16" Flat Free
#28-902	Steel	16" 4-ply Ribbed



### DOUBLE WHEEL MODELS

Part #	Handles	Tire
#11-676	Wood	16" 4-ply Knobby
#28-701	Wood	16" Flat Free
#28-703	Wood	16" 4-ply Ribbed
#28-901	Steel	16" 4-ply Knobby
#28-905	Steel	16" Flat Free
#28-903	Steel	16" 4-ply Ribbed

# 11-300/#11-681/#28-700/#28-702/#28-704/#28-706  
 # 28-900/#28-902/#28-904/#28-906/#28-908/#28-910

# Single Wheel Wheelbarrows

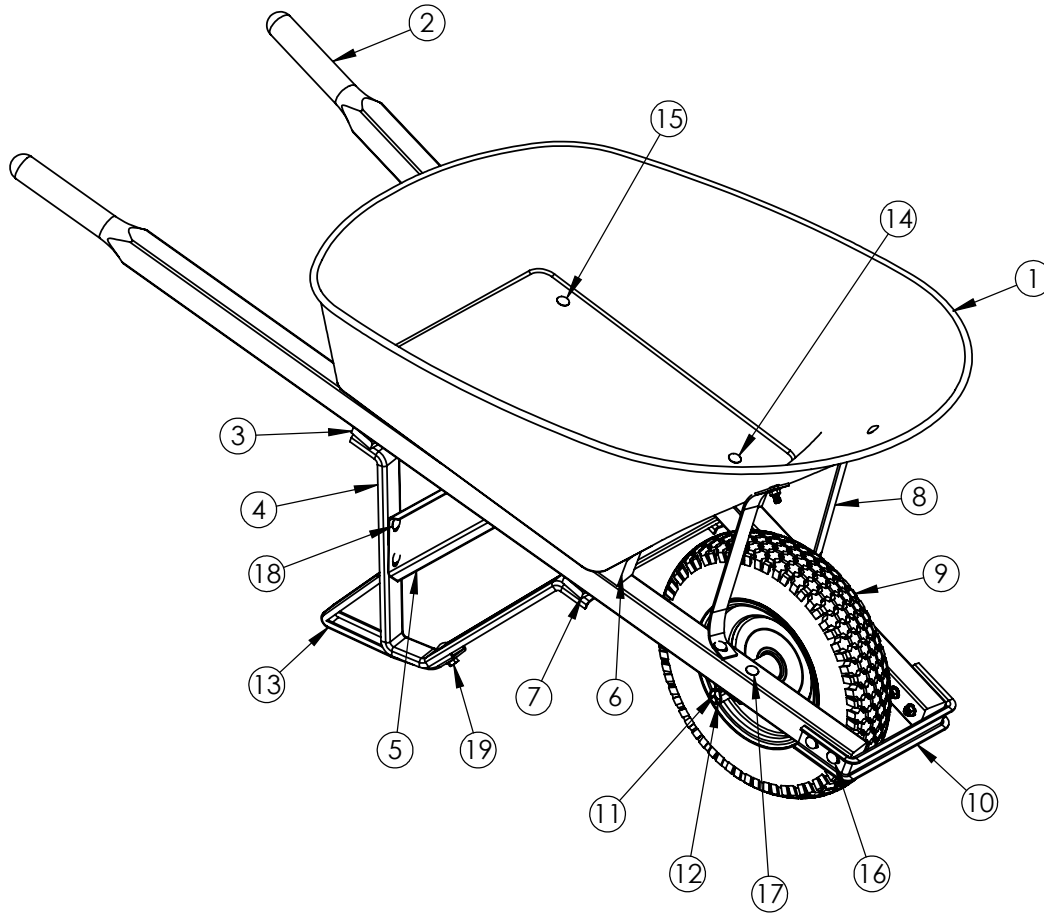

## Parts List

Key #	Part #	Detail	Qty/Unit	Key #	Part #	Detail	Qty/Unit
1	50-165	Steel Tray	1	10	50-326	Nose Piece	1
1	50-216	Poly Tray	1	11	50-245	Axle 9-1/2"	1
2	50-244	Wood Handles (pr)	1	12	50-327	Axle Bracket	2
2	50-532	Steel Handles (pr)	1	13	50-328	Leg Stabilizer	2
3	50-319	Rear Support	1	14	52-435	Carriage Bolt 5/16" x 5"	2
4	50-320	Leg	2	15	52-434	Carriage Bolt 5/16" x 3 3/4"	2
5	50-321	Leg Brace	1	16	52-433	Carriage Bolt 5/16" x 2 1/2"	4
6	50-323	Wedge	2	17	52-401	Carriage Bolt 5/16" x 2 1/4"	4
7	50-324	Front Support	1	18	52-438	Carriage Bolt 5/16" x 1"	8
8	50-325	Vertical Tray Brace	2	19	52-232	Serrated Nut 5/16"	20
9	50-174	Rim and Tire (Knobby)	1	n/a	52-127	Lock Washer	20
9	84-714	Rim and Tire (Flat Free)	1	n/a	80-102	Innertube 1	1
9	80-105	Rim and Tire (Ribbed)	1	n/a	80-101	Bearings (set of 2)	1
				n/a	50-329	Bag of Hardware -Tray	1

# Single Wheel Wheelbarrows

**Before assembling your Bon Wheelbarrow please make sure you have the following items.**

**NOTE: The wheelbarrow comes with ONE tray: steel or poly; ONE pair of handles: wood or steel; ONE wheel type: knobby, flat free or ribbed.**

**FOR PARTS LIST INFORMATION REFER TO PL11300**

KEY #	PART#	DETAIL	QTY/UNIT
1	50-165	STEEL TRAY	1
1	50-216	POLY TRAY	1
2	50-244	WOOD HANDLES (PAIR)	1
2	50-532	STEEL HANDLES (PAIR)	1
3	50-319	REAR SUPPORT	1
4	50-320	LEG	2
5	50-321	LEG BRACE	1
6	50-323	WEDGE	2
7	50-324	FRONT SUPPORT	1
8	50-325	VERTICAL TRAY BRACE	2
9	50-174	RIM & TIRE (KNOBBY)	1
9	84-714	RIM & TIRE (FLAT FREE)	1
9	80-105	RIM & TIRE (RIBBED)	1
10	50-326	NOSE PIECE	1
11	50-245	AXLE 9-1/2"	1
12	50-327	AXLE BRACKET	2
13	50-328	LEG STABILIZER	2
14	52-435	CARRIAGE BOLT 5/16" X 5"	2
15	52-434	CARRIAGE BOLT 5/16" X 3 3/4"	2
16	52-433	CARRIAGE BOLT 5/16" X 2 1/2"	4
17	52-401	CARRIAGE BOLT 5/16" X 2 1/4"	4
18	52-438	CARRIAGE BOLT 5/16" X 1"	8
19	52-201	SERRATED NUT 5/16"	20
N/A	80-102	INNERTUBE	1
N/A	80-101	BEARINGS	1
N/A	50-329	BAG OF HARDWARE - TRAY	1

## ASSEMBLING THE TRAY, HANDLES, AND LEGS

Place the steel or poly tray (key #1) upside down. Place one wedge (key #6) on the tray with the large end facing towards the front of the tray. Next, place one of the handles (key #2) on top of the wedge. Matching up the hole at the top back end of the tray, wedge, and handle, place the rear support (key #3) on top of those items. Finally, place one of the legs (key #4) on top of the rear support with the holes on the legs facing the back of the tray. Matching up the holes, place the 3-3/4" carriage bolt (key #15) in through the tray and then finger tighten one of the 5/16" nuts (key #19) onto the carriage bolt. Then place the front support (key #7) underneath the leg and put a 5" carriage bolt (key #14) through the tray, wedge, handle, front support,



and leg. Finger tighten a 5/16" nut onto the carriage bolt, and then do the same thing for the other side.

Attach the leg brace (key #5) by inserting it between the legs and then using the 1" carriage bolts (key #18) and 5/16" nuts (key #19). While attaching the leg brace (key #5) place the leg stabilizer (key #13) to the leg (key #4) and fasten with the nut (key #19).

## ASSEMBLING THE AXLE WHEEL

Attach the nose piece (key #10) by using the 2-1/4" carriage bolts (key #17) and 5/16" nuts (key #19). Place the axle bracket (key #12) on the wood handle. Attach the vertical tray brace (key #8) to the tray using a 1" carriage bolt (key #18) and a 5/16" nut (key #19). Place a 2 1/2" carriage bolt through the vertical tray brace, axle bracket, and handle and finger tighten one of the 5/16" nuts. Finish attaching the axle bracket by using a 2-1/2" carriage bolt and 5/16" nut.

Attach the other vertical tray brace to the tray by using another 1" carriage bolt and 5/16" nut. Before assembling the other axle bracket, put the axle (key #11) through the wheel (key #9) and position the axle through the axle bracket that is already attached. Place the other axle bracket on the axle and handle and use the other two 2-1/2" carriage bolts (key #16) and 5/16" nuts (key #19) to finish attaching the other axle bracket.

In order to center your tire, move the axle brackets (key #12) in against the wheel hub. Finish off assembly by tightening all of the nuts by using a 1/2" wrench or 1/2" socket.

## MAINTENANCE

Periodically, grease the fitting on the wheel hub. Also, keep your wheelbarrow clean from debris after using.

**Bon**<sup>®</sup>  
Trusted since 1958