

## SAFETY INFORMATION

For your own personal protection and for the safety of those around you, please read and ensure you fully understand the following safety information. It is the responsibility of the operator to ensure that he/she fully understands how to operate this equipment safely. If you are unsure about the safe and correct use of our SCREED, consult your supervisor.

Improper maintenance can be hazardous. Read and Understand this section before you perform any maintenance, service or repairs.



## **Safety Instruction**

- Ensure, that all symbols on the machine, can always be clearly read.
- Do not leave any tools or parts lying around on the work floor, as this can cause accidents.
- Watch where you are going, the ground can be slippery.
- Take care that you do not injure yourself on objects, such as scaffolding and reinforcement materials, which can be found directly or indirectly in the working area.
- Be careful when lifting and carrying the SCREED. Do not bend forwards when picking up the apparatus, bend you knees. Ensure that the working area is within your reach, that you do not have to bend forward.
- Ensure that no water or cleaning detergents get into the motor housing when cleaning
- When the machine is not being used for longer periods of time, ,then it must be stored in a dry and clean area.
- Pay attention to your own safety and the safety of your colleagues.
- Regular maintenance of the machine promotes safe operation.
- Suitable PPE must be worn when using this equipment i.e. Safety Goggles, Ear Protection, Dust Mask and Steel Toe capped footwear (with anti-slip soles for added protection). Wear clothing suitable for the work you are doing. Always protect skin from contact with concrete.

## **Operator Safety while using Internal Combustion Engines**

- Do not smoke when refueling the engine or during any other fuel handling operation.
- Do not run the engine near sparks or open flames.
- Do not start the engine if fuel has spilled or a fuel odor is present. Move the machine away from the spill and wipe the machine dry before starting.
- Do not refuel a hot or running engine.
- Do not refuel the engine near sparks or open flames.
- Do not spill fuel when refueling the engine.
- Do not touch the engine or muffler while the engine is on or immediately after it has been turned off. These areas get hot and may cause burns.
- If fuel is spilled during refueling, wipe it off from the engine immediately and discard the rag in a safe place. Do not operate the unit if fuel or oil leaks exist-repair immediately.
- NEVER operate this equipment in an explosive atmosphere.
- NEVER operate any gas powered equipment in a poorly ventilated or enclosed area.
- NEVER perform any work on the unit while it is running. Before working on it, stop the engine and disconnect the spark plug wire to prevent accidental starting.
- Avoid prolonged breathing of exhaust gases. You may be hurt by harmful exhausted gases.
- Avoid contact with hot exhaust systems and engine parts.
- Allow engine to cool before performing any repairs or service.
- ALWAYS transport and handle fuel only when contained in approved safety containers.
- ALWAYS keep the area around the muffler free of debris such as leaves, paper, cartons, etc. A hot muffler could ignite the debris and start a fire.

## **Service Safety**

- Read and understand the instructions contained in the manual delivered with the machine before servicing or maintaining
- Familiarize yourself with the location and proper use of all controls and safety devices before servicing or maintaining.
- Contact local dealer for additional training if necessary.
- Do not allow improperly trained people to service or maintain the machine. Personnel servicing or maintaining the machine must be familiar with the associated potential risks and hazards.
- Do not attempt to clean or service the machine while it is running. Rotating parts can cause severe injury.
- Do not remove blades while the machine is hanging overhead.
- Disconnect the spark plug on machines equipped with gasoline engines, before servicing, to avoid accidental start-up.
- When replacement parts are required for this machine, use only our replacement parts or those parts equivalent to the original in all types of specifications, such as physical dimensions, type, strength, and material.

## **OPERATION**

### **Assemble the Screed**

1. First determine whether you want to use screed as a form-to-form screeder or as a free screeder.
2. The screed is supplied in 2 components: the power-unit and the beam profile.
3. The power-unit is equipped with a quick disconnect system, with which the power-unit can be mounted on to the beam profile.
4. To connect the power-unit to the beam profile loosen the 3 wing bolts about 8mm, until the front clamping plate fits into the collar of the profile. Now tighten the 3 wing bolts.
5. Now unfold the twin control handle, adjust it to the proper height, and tighten the 2 clamps.
6. Make sure that the Screed Easy is properly assembled and that the ON-OFF switch is in the ON position.
7. Make sure that the fuel tank is filled with unleaded fuel only.
8. In case the screed is used for form-to-form screeding make sure that the forms are set to the right level.

### **Pre-Operation Check**

#### 1. Engine oil level

- Remove the oil filler cap and check the oil level: it should reach the top of the oil filter neck.
- If the level is low, fill to the top of the oil filler neck with the recommended oil.

Add the engine oil slowly to avoid overflowing, as the engine oil tank capacity is small.

Every 10 hours, check the engine oil level and replenish oil up to the top of the oil filler neck if the engine is operated for more than 10 hours continuously.

Use Honda 4-stroke, or an equivalent high detergent, premium quality motor oil certified to meet or exceed U.S. automobile manufacturer's requirements for service classification SG, SF. Motor oils classified SG, SF will show this designation on the container. SAE 10W-30 is recommended for general, all temperature use.

**NOTE:** Using nondetergent oil or 2-stroke engine oil could shorten the engine's service life. The recommended operating range of this engine is -5°C to 40°C (23°F to 104°F)

#### 2. Air cleaner

Never run the engine without the air cleaner. Rapid engine wear will result.

Check cleaner for dirt or obstruction of element.

#### 3. Fuel

Use automotive gasoline (Unleaded or lowleaded is preferred to minimize combustion chamber deposits).

Never use an oil/gasoline mixture or dirty gasoline. Avoid getting dirt, dust or water in the fuel tank.

#### 4. Retightening bolts and nuts

Check for loose bolts and nuts. Tighten the bolts and nuts properly and securely, if necessary.

## To Start

1. Turn the engine switch to the ON position (on the equipment side).
2. Move the choke lever to the CLOSED position.  
Note: Do not use the choke if the engine is warm or the air temperature is high.
3. Press the priming pump several times until a fuel flow in the fuel return tube is visually noticed.
4. Pull the starter grip lightly until resistance is felt, then pull briskly.
5. Gradually move the choke lever to the OPEN position. Warm up the engine until it runs smoothly.
6. Position the throttle control lever for the desired engine speed (on the equipment side).

## Operation and use of the SCREED

1. Place the screed beam on the rail supports or if you want to use the screed as a free screed, directly on the freshly poured concrete surface.
2. Now start the engine and allow a three minute warming-up period before setting the throttle handle to the desired engine speed.
3. After setting the engine speed start moving the screed backwards, the travel-speed depends on the consistency of the concrete.
4. After the job is finished, remove the Screed from the concrete and switch off the petrol engine.
5. After use, clean the screed according to the instructions described in the maintenance section of this manual. Place the screed on a dry, clean and stable surface.
6. If you do not expect to use the engine for a long period of time, drain the fuel tank and let the engine run at idle speed until the fuel in the carburetor is used and the engine stops.

### NOTE:

- Make sure to refill the fuel tank in time. Do not let the engine run so all the fuel is used. This might cause starting problems.
- Prevent the screed from sinking into the concrete. After the engine has been switched on, immediately move the Screed Easy backwards.
- When using a low slump concrete, move the screed slowly across the surface of the concrete. When using a high slump concrete, move the screed faster across the surface of the concrete.
- When the screed is used as a wet screed it is recommended to first compact the freshly poured concrete with a poker vibrator while at the same time set the height of the floor by means of a laser device.

## 2.5 Operation

The drive-unit of the screed is started by pulling the recoil-starter of the engine. The vibrating beam of the screed compacts, levels and smooths freshly poured concrete in one operation. The screed features a dual purpose beam and can be used for form-to-form screeding or for free screeding.

By rotating the power-unit 180 degrees, the operator can choose between screeding, using forms/rails, or free screeding.

## **To Stop**

To stop the engine in an emergency, turn the engine switch to the OFF position (on the equipment side). Under normal conditions, use the following procedure:

1. Position the throttle control lever fully to LOW (on the equipment side).
2. Turn the engine switch to the OFF position (on the equipment side).

## **MAINTENANCE**

The screed is designed to give many years of trouble free operation. It is recommended that an approved dealer carries out all major maintenance and repairs. Always use our genuine replacement parts, the use of spurious parts may void your warranty.

It is recommended to spray the aluminum blade and quick disconnect prior to operation, with a high quality form oil.

Clean the quick disconnect and beam on a daily basis.

Only qualified personnel, familiar with the contents of this operation manual, are allowed to carry out maintenance and repair jobs to the screed.

After use store the screed in a clean, dry and dust free place.

## **Daily Service**

In order to achieve a maximum cooling effect the ventilation openings must stay free from dirt, grease and concrete. Check them at the end of each working day. If necessary clean them with a brush or a damp cloth. For detailed engine servicing instructions, please read the operation instructions supplied by the manufacturer.

## **TECHNICAL DATA**

### **Technical Specification**

Model	82-546 / #82-547	
Engine type	Honda GX35	
Power	kw(hp)	1.2(1.6)
Weight without blade	kg(lb)	20(44)
Engine Max. Rated Speed	rpm	7000

### **Blades**

Model	82-492	82-493	82-494	82-495	82-496	82-497	82-498
Blade Size ft.	4'	6'	8'	10'	12'	14'	16'
Weight lbs	6.4 lbs	9.6 lbs	12.8 lbs	16.0 lbs	19.2 lbs	22.4 lbs	25.6 lbs

**Dimension (A X B X C): 18" x 26" x 39"**

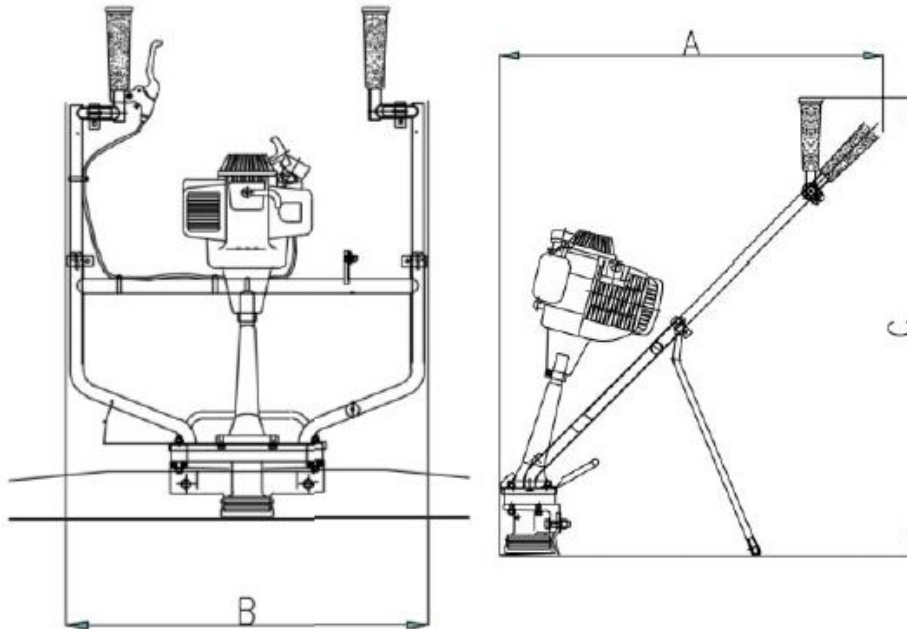

**Hand-Arm vibration Specification (According to ISO 5394, EN 1033 and EN500-4):**  
7.8m/s<sup>2</sup>