

INSTRUCTIONS

#15-560 Drywall Versa Lifter

Handle for Tilting the Top Rack

Please read through instructions carefully before the first use. Follow all safety instructions in order to avoid injuries or damages. Follow operating instructions to avoid damage to equipment.



PRECAUTIONS BEFORE USE

- Make sure all the parts are well assembled
- Make sure all the nuts are tight and the removable pins are in position.
- Remove the dust from the gear and the rack and pinion.
- Make sure the retractable pins are well locked in place.
- Before each use, make a general operational checking.
- Make sure the cable is in good condition. Do not hesitate to change it as soon as wear is visible : crushing, pinching, wire breaking.
- Make sure the main brake is in good condition and well adjusted. Once the board lifted at the required height, it has to stay in position when the safety brake is unlocked.

GENERAL SAFETY WARNINGS

- Use tool only as intended for plasterboard installation.
- Do not exceed the maximum weight load.
- Do not use as a freight elevator or person elevator.
- Do not grease or oil the rack and pinion.
- The top rack must be in low position while changing the feet position.
- Do not use the tool carrier wooden board as a working platform.
- Do not hinder the wheels while using.
- Do not clutter up the working area.
- Do not put your hand through the steering wheel while the top rack is lowering. It may cause hand or finger injuries.
- Do not let children use the Bon Versa Lifter.
- Do not erase the Bon Versa Lifter warning markings.
- Make no modifications to product.
- Once the board lifted at the required height, it has to stay in position when the safety brake is unlocked. If the board goes down, tighten the main brake by turning the knurled nut clockwise direction. If the board is heavier than a standard board (more than 25 kg), turn the knurled nut clockwise direction to increase the spring power. If the board still goes down even with the knurled nut at its tightest, change the brake lining.
- Use on a firm and stable surface which can support the weight of the tool and plasterboard.
- Lock the 2 wheel brakes while lifting a board.
- Ensure the safety of the other people around the Bon Versa Lifter.
- In order to avoid collision with the top rack during its descent, use the main brake to regulate the speed. In case of a main brake default, release immediately the safety brake lever in order to stop the descent right away.
- Follow all local, state, federal and OSHA regulations.

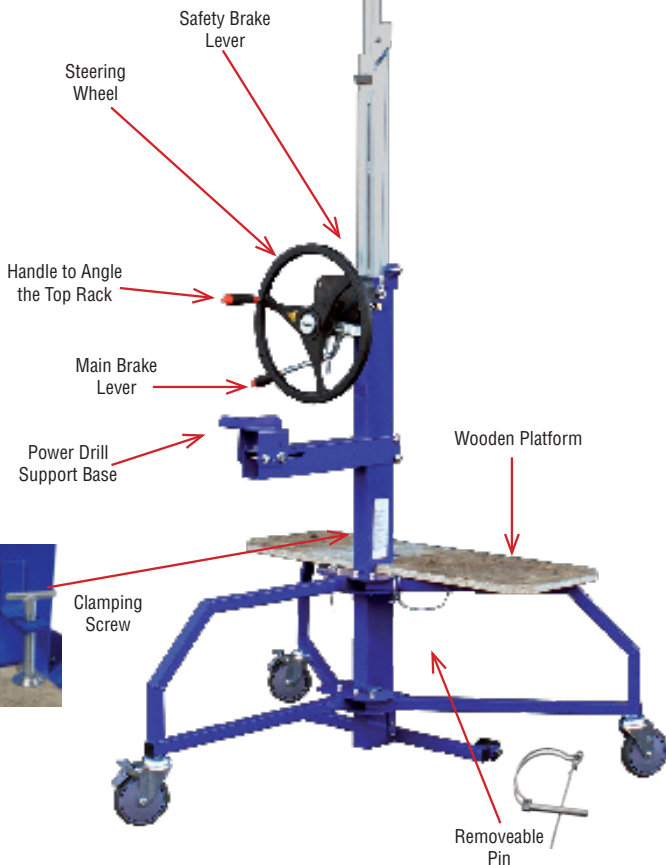

SPECIFICATIONS :

- Maximum loading weight: 175 lbs.
- Maximum board dimensions: 4' x 12'
- Minimum board dimensions: 6" x 24"
- Maximum height with extension part: 14' 9"

- Maximum height without extension part: 11' 6"
- Minimum height: 5' 3"
- Maximum height for vertical lifting with 8' height board: 20' 6"
- Board loading height: 2' 9"

- Minimum wheelbase width in working position: 3' 4"
- Minimum width in moving/storage position: 24 - 3/4"
- Total gross weight: 117 lbs.

RECOMMENDED TOOLS : 1/2" flat wrench, 1/4" hex wrench

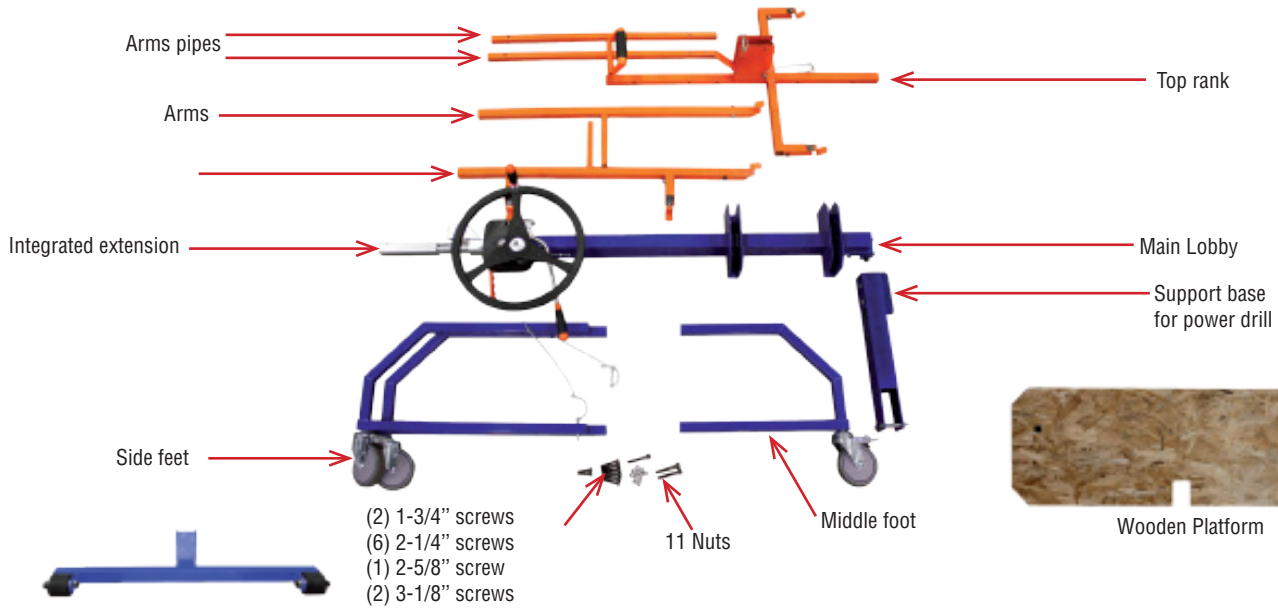

ASSEMBLY INSTRUCTIONS

1. Fix the balance bar with wheels to the main body with the two 3-1/8" screws and nuts. Use a 1/2" flat wrench and a 1/4" hex wrench.

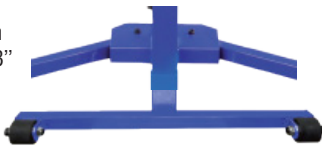

2. Fix the lateral and central feet to the base frame with the six 2-1/4" screws and nuts. Use a 1/2" flat wrench and a 1/4" hex wrench. Position the side feet with brake on the same side than the security and main brake levers.

The central foot is the shortest foot. The central foot nuts have to be firmly tightened because it doesn't rotate like the side feet.



3. Open the 2 side feet and insert the removable pin in the base frame hole following the selected configuration.



HORIZONTAL CEILING SETTING AND SLOPING CEILING



VERTICAL SETTING



STORAGE/MOVING POSITION

4. Insert the 3' extension in the frame and lock it in the selected hole with the corresponding removable pin. The extension has 3 different height positions 11' 6", 13' and 14' 9".

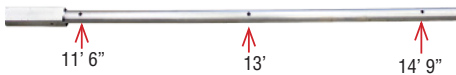

5. Insert the top rack in the extension base and fix it with the 2-5/8" screw and nut.



6. Assemble the arms with the two 1-3/4" screws and nuts, using a 1/2" flat wrench and a 1/4" hex wrench. Make the arms marks match : R with R, and L with L.



7. Insert the arms in the top rack according to the position selected. When you are in front of the steering wheel, put the R arm on your right and the L arm on your left. The retractable pins must be locked in the corresponding holes.



8. Fix the power drill support base to the main body with the 2 provided screws and tighten the wing nuts to lock the support base.

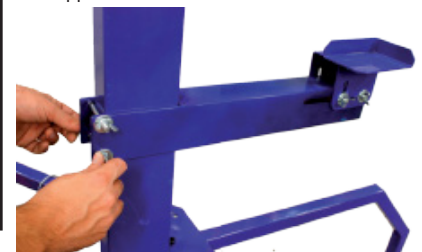

OPERATING INSTRUCTIONS

1. Lift the latch to unlock the top rack and tilt it completely.



2. Insert the arms in the tube according to the selected setting, the retractable pin must be locked in the hole.

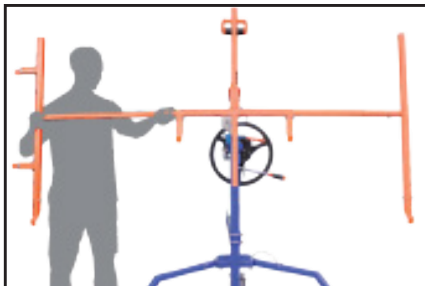

3. Block the 2 wheel brakes, then load the board.



4. Pull the handle to position the board on the chosen configuration.



OPERATING INSTRUCTIONS (CON'T.)

5. Unlock the 2 wheel brakes and turn the steering wheel while pushing the main brake lever to lift the board.



6. Once the board touches the ceiling, position the board perfectly and lock the wheel brakes while screwing the board.



6. Push the brake lever while lifting the safety brake latch, to lower the top rack. If you have to lower the top rack loaded, pay attention to control the descent by pushing slightly on the main brake lever.

In case of a main brake default, release immediately the safety brake lever in order to stop the descent right away.



CEILING SETTING INSTRUCTIONS

1. Open the feet as much as possible and insert each removable pin in the 3rd hole of the base frame.

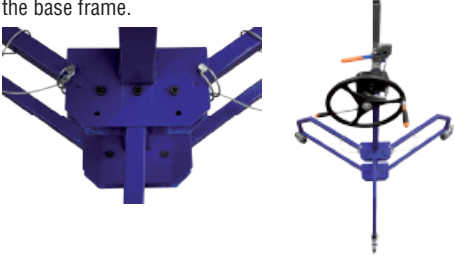

2. Insert the arms in the horizontal tubes, the retractable pin must be locked in the selected hole.

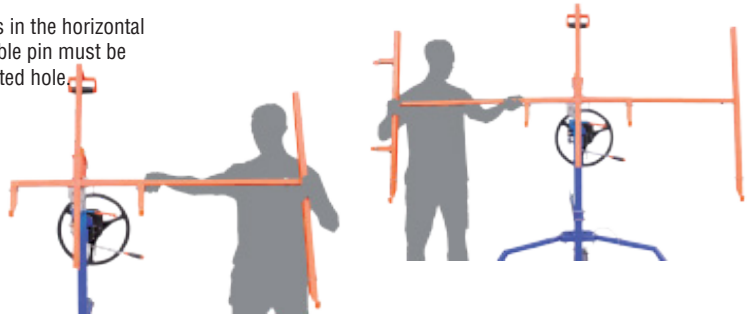

3. CEILING SETTING

Once the board loaded, pull the top rack handle to put the board in horizontal position. Position the Versa Lifter with the steering wheel in front of the wall to lift the board along the wall.

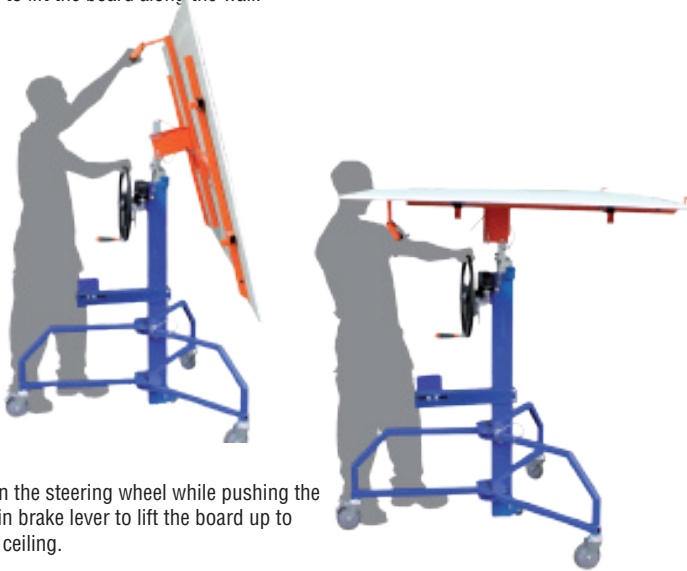

Turn the steering wheel while pushing the main brake lever to lift the board up to the ceiling.

HORIZONTAL SLOPING CEILING

Once the board loaded, pull out the removable pin to unlock the top rack, then pull the handle to angle the board. Insert the removable pin in the sloping ceiling position hole (45° position). The top rack position is adjusted according to the ceiling angle while the board is touching the ceiling.



LOADING CONFIGURATIONS

1. Insert the arms in the vertical tubes, the retractable pin must be locked in the selected hole according to the board dimensions
 - 1st hole for vertical sloping ceiling
 - 2nd hole (with "vertical position" marking) for vertical setting.

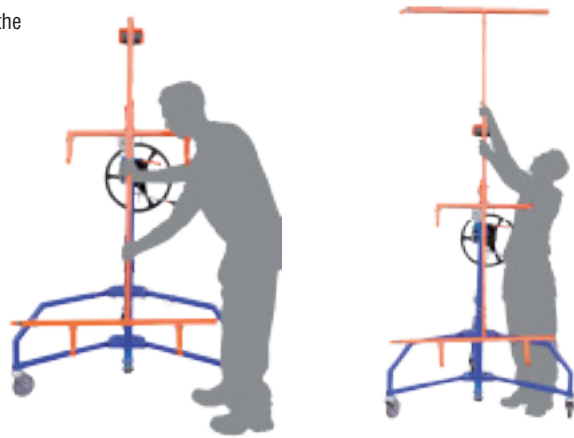

2. VERTICAL SLOPING CEILING

Once the board loaded, pull out the removable pin to unlock the top rack, then pull the handle to angle the board and insert the removable pin in the sloping ceiling position hole (45° position). The top rack position is adjusted according to the ceiling angle while the board is touching the ceiling.

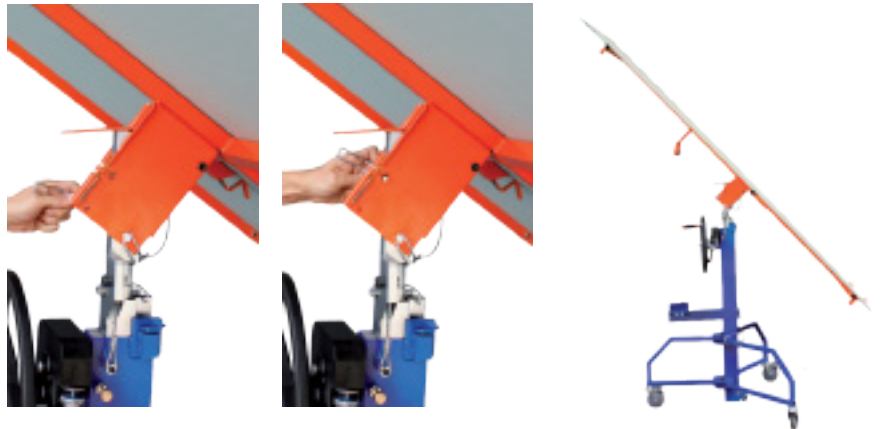

VERTICAL SETTING

Once the board loaded, position the Bon Versa Lifter along the vertical wall. Pull out the removable pins from the 2 lateral feet and open them up to the 2nd hole of the frame base. Insert the removable pins to lock the feet. Pull out the removable pin from the top rack in order to angle the board completely on vertical position, while pushing the Bon Versa Lifter along the wall thanks to the top rack handle. Lock the 2 wheel brakes.

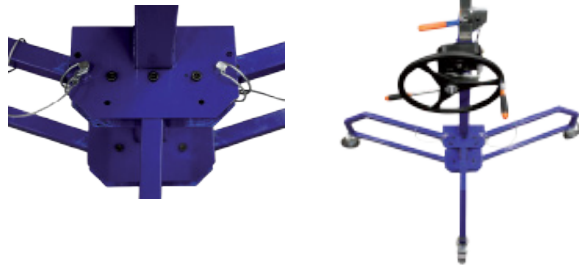

3. Turn the steering wheel while pushing the main brake lever to lift the board.

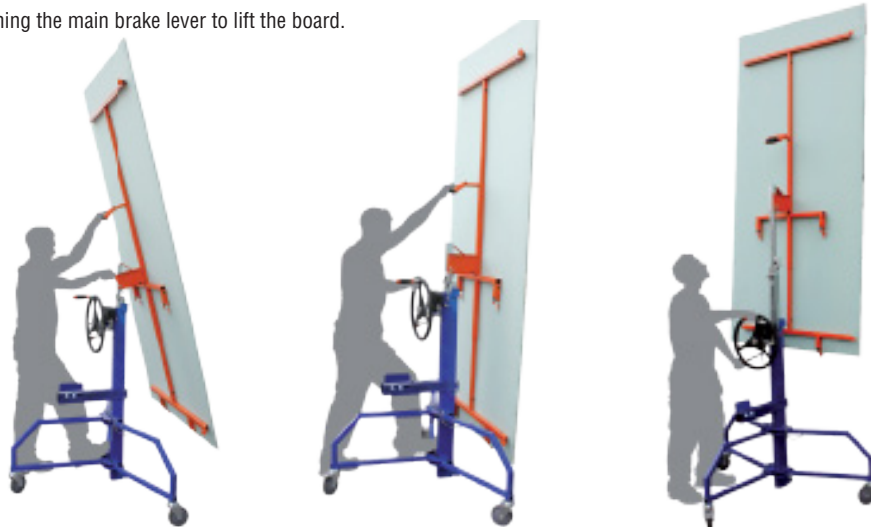

AUTOMATIC USE ASSISTED BY POWER DRILL

1. First of all, you must use the power drill support base for safety reasons. Then, set up the Bon Versa Lifter according to the selected setting configuration.

Insert the hex bit in the power drill chuck



2. Adjust the power drill support base according to the power drill dimensions.



3. Insert the hex bit fixed to the power drill, in the hex hole located in the middle of the steering wheel. Turn the power drill to block it against the power drill support base. Set the power drill on "maximum torque - low speed", rotating on clockwise direction.



4. Pull the power drill trigger to lift the board.

To lower the top rack, remove the power drill first, then push the main brake lever while lifting up the safety brake latch.



CABLE REPLACEMENT NECESSARY TOOLS : 3/8" and 11/16" flat wrench, 3/16" and 5/16" hex wrench

WITHDRAWAL OF USED CABLE

1. Unscrew the axis maintaining the pulley and remove it with a 11/16" flat wrench and a 5/16" hex wrench.



2. Pull the internal tube out.



3. (A) Remove the pulley.

(B) Unscrew the nut from the axis maintaining the cable to the main body. Use a 3/8" flat wrench and a 3/16" hex wrench.

(C) Unscrew the screw from the main body with a 3/16" hex wrench, in order to remove the cable completely.

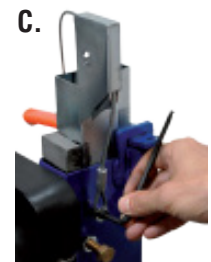
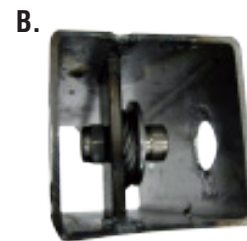

CABLE REPLACEMENT (CON'T.)

INSTALLATION OF NEW CABLE

1. Put the axis through the cable loop to fix it to the internal tube.
2. Fix the opposite cable loop to the main body with the provided screw.
3. Put the pulley back to its location.
4. Put the principal tube back in the main body.
5. Put the axis maintaining the pulley back and tighten the nut on the axis with a 11/16" flat wrench and a 5/16" hex wrench. For this step, the internal tube must not be completely inserted in the frame.

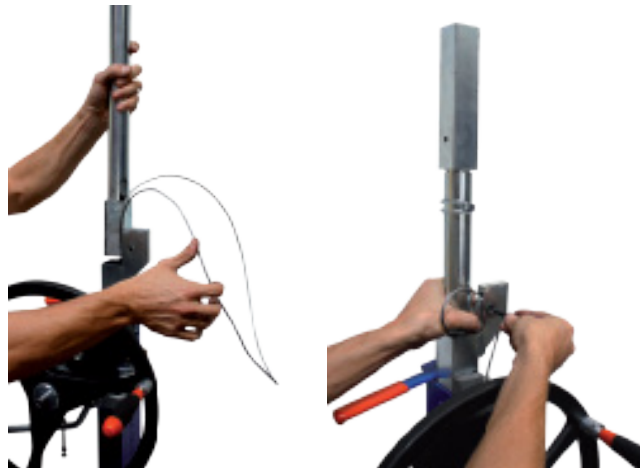

BRAKE LINING REPLACEMENT *NECESSARY TOOLS : 1/4" hex wrench*

WITHDRAWAL OF BRAKE LINING

1. Unscrew the central axis of the steering wheel with a 6 mm (1/4") hex wrench.



2. Remove the spring by lifting the main brake lever.



3. Pull the steering wheel to remove it from the axis. Be careful not to lose the small key while pulling the steering wheel.



4. Pull the brake lining to remove it from its location.



NEW BRAKE LINING INSTALLATION

1. Insert the brake lining in its location.
2. Put the steering wheel on the main axis and make sure that the small key is in its location.
3. Replace the spring.
4. Screw the steering wheel central axis.



#15-560

Drywall Versa Lifter

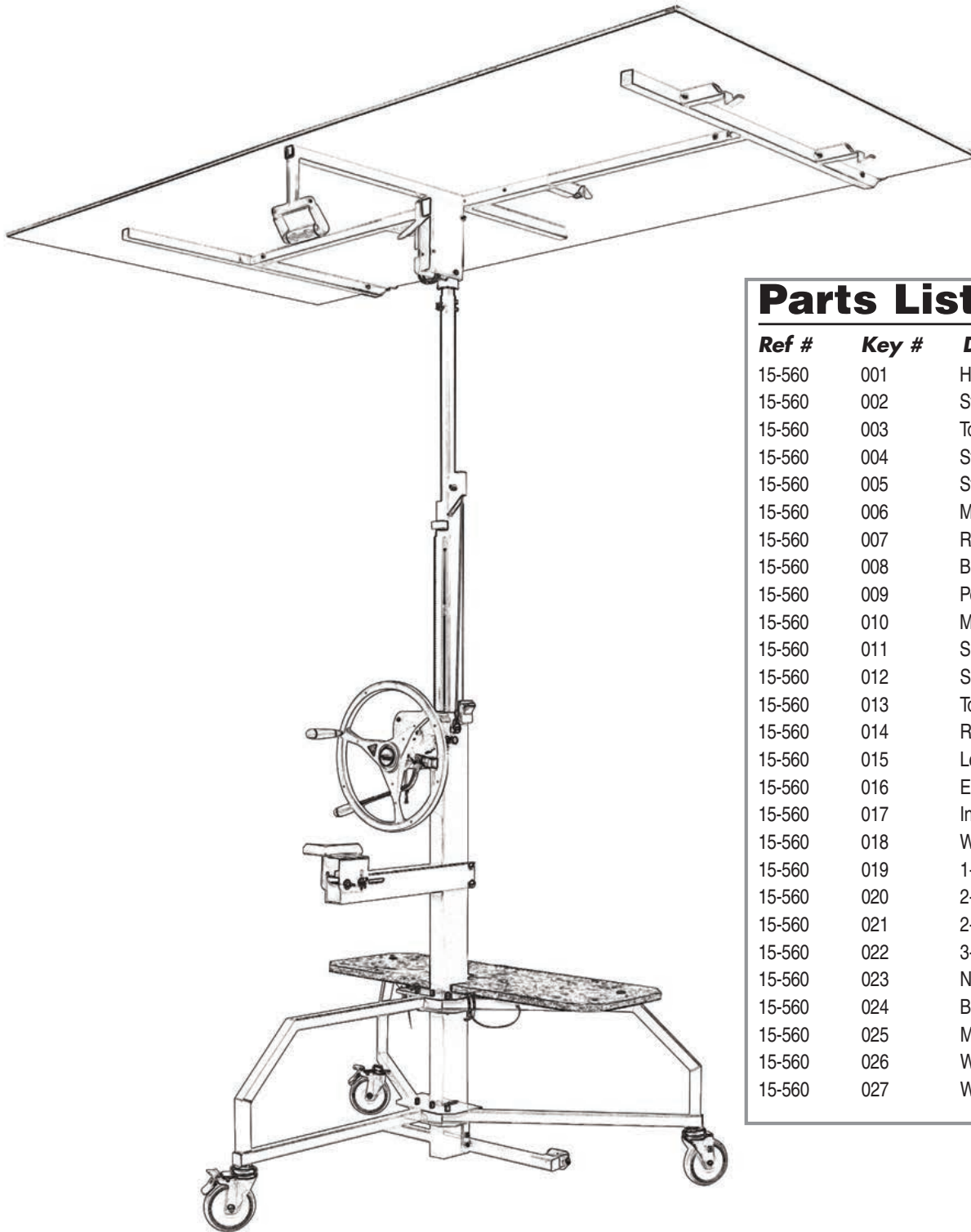

Parts List

Ref #	Key #	Detail
15-560	001	Hex bit for use with power drill
15-560	002	Steering wheel central screw
15-560	003	Top rack retractable stopper
15-560	004	Steering wheel
15-560	005	Steering wheel handle
15-560	006	Main brake lever
15-560	007	Removable pin
15-560	008	Balance bar with wheels
15-560	009	Power drill support base
15-560	010	Middle foot
15-560	011	Side foot with brake
15-560	012	Side foot without brake
15-560	013	Top rack
15-560	014	Right arm
15-560	015	Left arm
15-560	016	Extension tube
15-560	017	Internal tube
15-560	018	Wooden platform
15-560	019	1-3/4" screw & nut
15-560	020	2-1/4" screw & nut
15-560	021	2-5/8" screw & nut
15-560	022	3-1/8" screw & nut
15-560	023	Nut
15-560	024	Brake lining
15-560	025	Metallic cable
15-560	026	Wheel with brake
15-560	027	Wheel without brake

Bon[®]
Trusted since 1958

When it comes to quality concrete, masonry, drywall tools, Bon Pro Plus is the brand you can depend on.