

# INSTRUCTIONS

# #14-558 / #14-549 Floor Tile Cutter

## INTRODUCTION

Your 18" PVC Tile Cutter cuts 18" horizontally, and will cut a 12" PVC tile diagonally, from corner to corner. The 12" PVC Tile Cutter cuts 12" horizontally, and a 9" tile diagonally.

These cutters are engineered to provide dependable service, and use components proven for over 25 years in the 12". The 18" features a reinforced front wall and thicker base in the strong, lightweight main aluminum casting. The carbon steel cutting knife is sharpened at the factory to cut easily and smoothly.

Note: It is recommended that the blade be wiped with a light oil after use to retard rust. The blade can be sharpened or "dressed" with a fine sharpening stone, and replacement blades are available.

The cutters also include three white rubber feet (stored on the bottom) for stable, stationary use.

## CAUTION

- A. *The cutting knife blade is very sharp! Make sure the cutting area is clear of fingers, tools, and debris before operating.*
- B. *Keep hands and fingers clear of the bottom of the blade when operating. The handle can move down quickly when the tile is cut through. Keep fingers clear of the area beneath the handle.*
- C. *The handle can also snap upward due to the spring loaded blade return. Keep your hand on the handle throughout the range of travel.*
- D. *Do not cut material other than that described in "Operating Tile Cutter" below. DO NOT ATTEMPT TO CUT METAL, WOOD, PLASTIC LAMINATE OR OTHER MATERIALS FOR WHICH THE CUTTER IS NOT DESIGNED!*

## OPERATING TILE CUTTER

### A. Material

PVC tile cutters are designed to cut Solid Vinyl Tile, Vinyl Composition Tile (VCT), and Cork Tile, up to 1/8" thick. DO NOT ATTEMPT TO CUT ANY OTHER MATERIAL.

1. Cold tile is brittle and hard to cut. Extremely cold tile can fracture or crack. Make sure tile is at "room temperature" (72°) or above for best results.

### B. Adjusting the Blade Angle

1. The height and angle of the top cutting blade can be adjusted by turning the two plastic knob adjustment screws on the left and right vertical posts.
2. For best results, with the handle in the UP position, set the height of the cutting blade on the right side (nearest the handle) slightly above the height of the tile you are cutting. Set the left side of the blade about 1/8" higher than the right side.
3. Check that the left side of the cutting blade goes completely down to the lower cutting bar by moving the handle full down. This is to ensure that the cutting action occurs through the entire length of the blade.
4. If the left side of the cutting blade does not go completely down to the bottom cutting bar, turn the adjustment knob to lower the left side of the cutter blade so it is just below the bottom cutting bar.

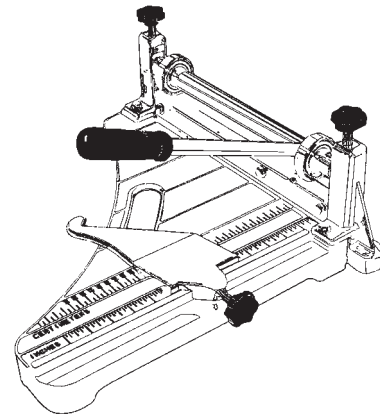
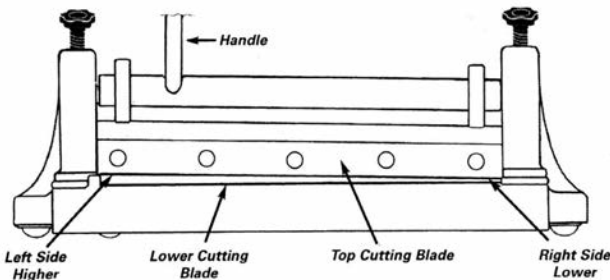

### C. Cutting Tile

1. To cut tile, place the piece in the cutter, and hold the tile firmly against the guide bar on the right side of the table. The inch and metric scales are reasonably accurate. If you want a piece of tile approximately 6" long, put the edge of the tile against the 6" mark. For precise cuts, scribe the tile on the exact location you want to cut, then position the scribed line under the cutting blade.
2. For 45° miter cuts, use the miter guide to position your tile at a 45° angle to the blade. The miter guide can be moved back and forth by loosening the setscrew. Again, for precision cuts, scribe your tile and align the mark with the cutting blade.
3. The forward edge of the miter guide can also be used as a "stop gauge" if you are cutting a number of tiles the same length. Before setting the "stop", measure carefully or set the stop with a scribed tile.
4. When doing inlays, or other high precision cutting, scribe your tile carefully, then align your scribe marks under the cutting blade. Hold the tile firmly as you lower the cutting handle. **Again – WATCH YOUR FINGERS.**

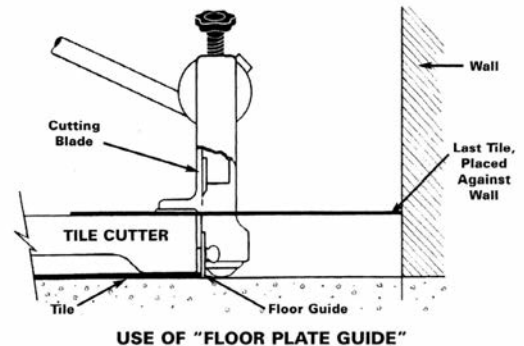

### D. Using the "Floor Guide"

1. The stamped metal guide located on the front of the aluminum base, and held in place with two plastic screws, is a very handy guide for cutting the last tile against the wall. Set the floor guide as low as it will go, and put the guide against the last tile, as shown.
2. Put a piece of tile cutter, push the tile against the wall, and cut the tile. The cut piece will fit between the wall and the last tile you have laid

## **MAINTENANCE**

### **A. To keep your PVC Tile Cutter working properly and efficiently please follow these guidelines:**

1. Don't expose the cutter to water, or leave it outside.
2. Wipe the cutter blades (top and bottom) with an oily rag after each use to retard rust. WD-40 is a good example of a rust retarding oil.
3. Also wipe the other shiny metal parts occasionally with an oily rag. Wipe off excess oil so it does not soil vinyl tile.
4. Put a few drops of oil in the ball bearing cutter actuators occasionally.
5. The edge of the cutting blade should be "dressed" on occasion to remove nicks, and to sharpen the blade.
  - a. Remove the top cutting blade from the tile cutter by removing the five hex head bolts and washers.
  - b. Place a long, fine grain oilstone on a flat surface.hone the beveled edge of the cutting blade by sliding the blade lightly back and forth over the stone a few times.
    - **HONE ON THE BEVELED SIDE ONLY**
    - **HOLD THE BLADE** at the **SAME ANGLE** as the angle of the bevel, i.e. keep the beveled edge flat on the oil stone.
  - c. After the beveled edge has been honed, make one pass of the opposite (flat) side of the blade over the stone to remove the burr, or "flash".
  - d. **DO NOT** attempt to dress the blade:
    - With a file
    - On a grinding wheel
    - While still mounted on the cutter
  - e. Put the blade back on the cutter, making sure it is seated against the two positioning pins. Then, replace the five hex head bolts and washers, securing the bolts tightly.
  - f. Wipe the blade with an oily cloth.
  - g. You can order replacement blades from your local Bon Tool distributor.
6. Clean dust and debris off the tile cutter after use. An occasional coat of wax on the base will keep your cutter operating smoothly and reduce tarnish. Treat your cutter with care, like any fine tool, and it will provide years of dependable service.

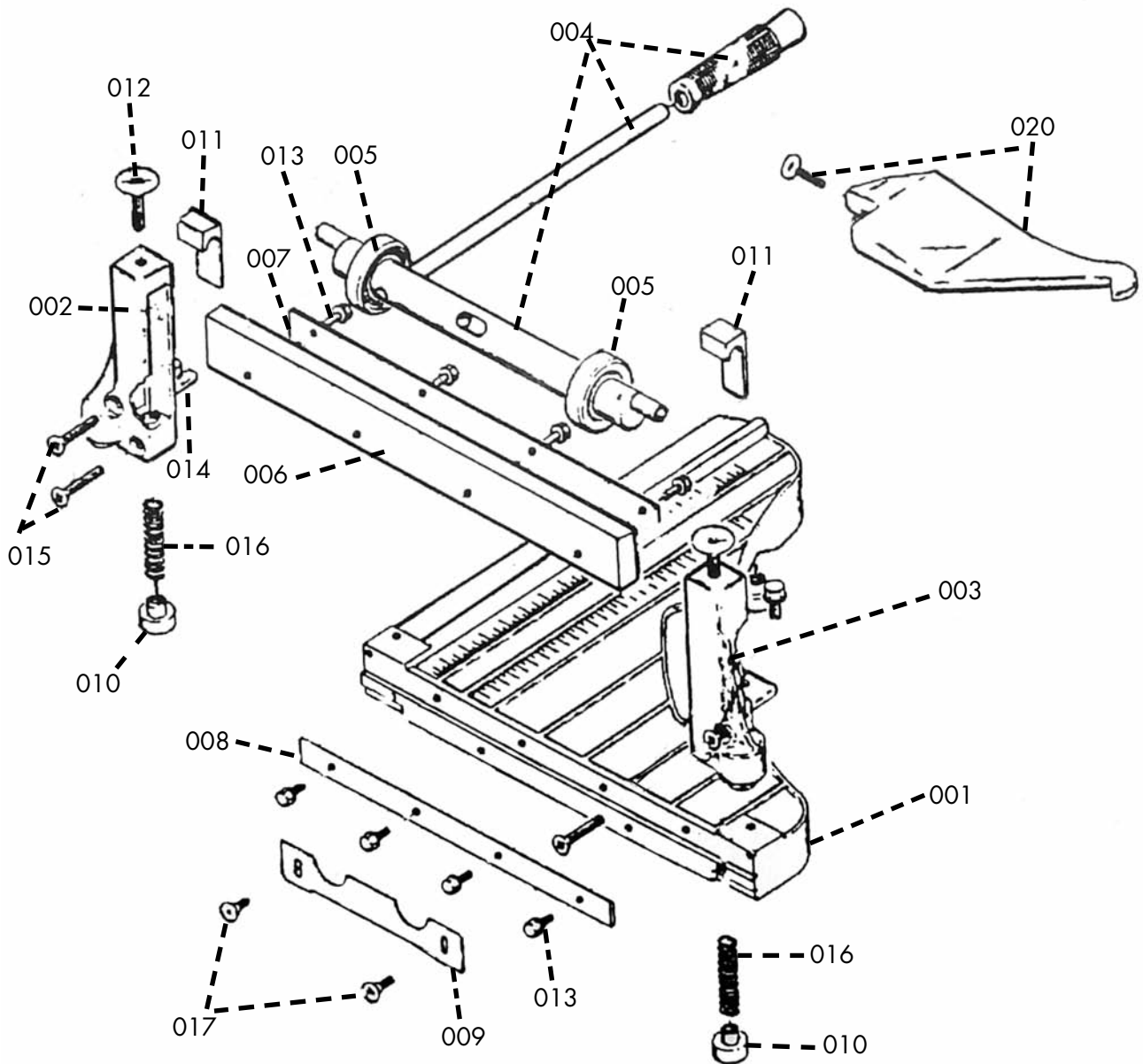

## Parts List

Ref #	Key #	Detail	Qty/Unit	Ref #	Key #	Detail	Qty/Unit
14-549	001	Base Casting	1	14-549	011	Inner Cam Bearing	2
14-549	002	Right Standard	1	14-549	012	Crankshaft Adjustable Screw	2
14-549	003	Left Standard	1	14-549	013	1" Hex Head Bolts	8
14-549	004	Crankshaft Handle	1	14-549	014	1" Hex Head Bolts	2
14-549	005	Crankshaft Ball Bearing	2	14-549	015	Flat Head Phillips Screw 1 1/2"	4
14-549	006	Blade Carrier	1	14-549	016	Springs 1/2" x 2 1/2"	2
14-549	007	Top Blade	1	14-549	017	Head Hex Bolts 5/8"	2
14-549	008	Bottom Blade	1	14-549	019	Rubber Stop	3
14-549	009	Floor Guide	1	14-549	020	Cutting Guide w/Screw	1
14-549	010	Spring Block	2				