

**HOLEMAKING & AUTO BODY
SOLUTIONS FOR THE PROFESSIONAL™**

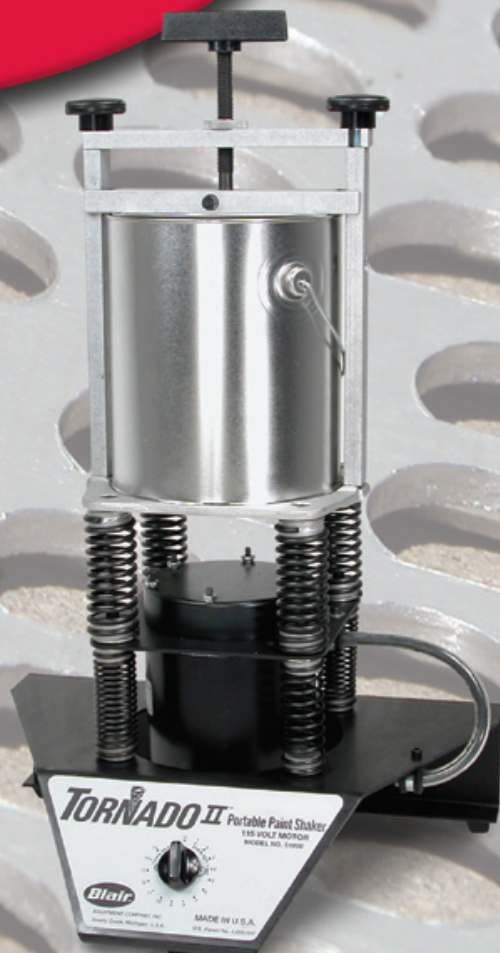

NEW!



TORNADO II Portable Paint Shaker
115 VOLT MOTOR
MODEL NO. 1099

Blair
MADE IN U.S.A.

ROTABROACH® CUTTERS



Cut Holes 3x faster & lasts 10x longer than twist drills or hole saws

For precision holemaking in sheet metal and frame materials up to 1/2" thick. Blair Rotabroach Annular Cutters make clean, burr-free, round holes with no deforming of stock or damage to the surrounding material. Ideal for sheet metal fabrication or PDR and rustproofing access holes because the snap-in plugs fit perfectly. Custom builders and aftermarket equipment installers can also count on the superior quality holes.

Rotabroach Cutters are precision ground and made of M2 H.S.S. with a patented tooth geometry that also prevents chip clogging whether cutting steel, sheet metal or plastics. Unlike hole saws and twist drills that push and tear through materials, these cutters will make hundreds of holes with no deforming of stock, jagged edges or out-of-round holes.

Arbors for Rotabroach Cutters fit 3/8" and 1/2" hand held drill chucks and use either spring loaded pilots or skip-proof pilots which eliminate pre-drilling operations. Made in USA.

ARBORS

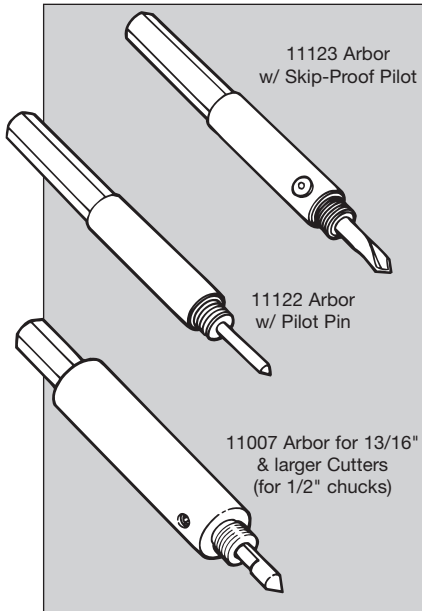

ARBORS

Part Number	Description
For 3/8" and larger drill chucks	
11123	Arbor w/ Skip-Proof Pilot for 3/8" (10mm) to 3/4" (20mm) Cutters
11122	Arbor w/ Pilot Pin for 1/4" (6mm) to 3/4" (20mm) Cutters
For 1/2" and larger drill chucks	
11007	Arbor for 13/16" to 1-1/2" Cutters

PILOTS

Part Number	Description
11097	Pilot for 11123 Arbor (3pk)
11121	Pilot for 11122 Arbor (3pk)
11628	Pilot for 11007 Arbor (3pk)

Kits available with popular sizes for general holemaking, PDR access holes, rustproofing, and spotweld removal. See Page 7.

Diameter (Inches)	Decimal Equivalent	Part Number
Use Arbor 11122 • 1/4" D.O.C.		
1/4	.2500	11100-3
9/32	.2812	11102-3
5/16	.3125	11104-3
11/32	.3438	11106-3
Use Arbor 11122 or 11123 • 1/4" D.O.C.		
3/8	.3750	11108-3
13/32	.4062	11110-3
7/16	.4375	11112-3
29/64	.4531	11113-3
15/32	.4688	11114-3
1/2	.5000	11116-3
17/32	.5312	11118-3
9/16	.5625	11120-3
5/8	.6250	11124-3
11/16	.6875	11128-3
23/32	.7188	11130-3
3/4	.7500	11132-3
Use Arbor 11007 • 1/2" D.O.C.		
13/16	.8125	11336
7/8	.8750	11340
15/16	.9375	11344
1	1.0000	11348
1-1/16	1.0625	11352
1-1/8	1.1250	11356
1-3/16	1.1875	11360
1-1/4	1.2500	11364
1-5/16	1.3125	11365
1-3/8	1.3750	11366
1-7/16	1.4375	11367
1-1/2	1.5000	11368
Diameter (Metric)	Decimal Equivalent	Part Number
Use Arbor 11122 • 1/4" D.O.C.		
6mm	.2362	11206-3
7mm	.2756	11207-3
8mm	.3150	11208-3
8.5mm	.3346	11285-3
9mm	.3543	11209-3
Use Arbor 11122 or 11123 • 1/4" D.O.C.		
10mm	.3937	11210-3
11mm	.4331	11211-3
12mm	.4724	11212-3
13mm	.5118	11213-3
14mm	.5512	11214-3
15mm	.5906	11215-3
16mm	.6299	11216-3
17mm	.6693	11217-3
18mm	.7087	11218-3
19mm	.7480	11219-3
20mm	.7874	11220-3

All cutters ending in (-3) are sold as a 3 pack.

STEP DRILLS

- Premium Cobalt M42 for long tool life
- Faster starting with Blair split point
- Angled double flute for faster penetration
- TiN coated for increased tool life & improved hole quality

Part Number	Description	Depth
35400	1/8" to 1/2"	1/8"
35401	3/16" to 1/2"	3/8"
35402	3/16" to 7/8"	1/8"



SPOTWELD DRILL

Remove Spotwelds Fast on All Types of Metals

- Low Speed 800 RPM - Better for UHSS & Boron
- Manual Feed w/ Leverage Handle Increases Cutter Performance (No air power is consumed to advance the cutter, resulting in more torque and faster spotweld removal)
- Adjustable Cutting Depth
- Two 360° Swivel Frame Clamps (Included)
 - 2-5/16" and 5-5/8" depth
- Low Noise
- Built in Comfort Grip
- Includes (1) 8mm Triple-Fluted Solid Carbide Drill Bit
- Additional Sizes of Carbide Spotweld Drills
 - Part No. 11306 (6.5mm)
 - Part No. 11308 (8mm)
 - Part No. 11310 (10mm)
 - Part No. 11312 (12mm)

Specifications

Cutter RPM:	800
Air Pressure:	90 psi
Air Consumption:	4 CFM (113 L/min)
Length:	13-15/16" (346mm)
Height:	9-1/4" (235mm)
Width:	2" (50mm)
Weight:	5.5 lbs (2.5 kg)
Noise Level:	84dB



Part No. 11300

Patented



PREMIUM SOLID SPOTWELD CUTTERS



Drill out Boron spotwelds fast with the Premium Solid Spotweld Cutter. Made from solid carbide for long tool life in today's high strength, extremely hard body panels. Designed for use on UHSS, Boron and standard automotive steels. It is self centering and has an easy cutting action, leaving no damage to underlying panels. Double coated for maximum durability. For use with the Blair Enforcer™ Spotweld Drill or "gun" type spotweld tools. Made in USA.



Diameter	Part Number
6.5mm	11306
8mm	11308
10mm	11310
12mm	11312

PREMIUM SPOTWELD CUTTERS

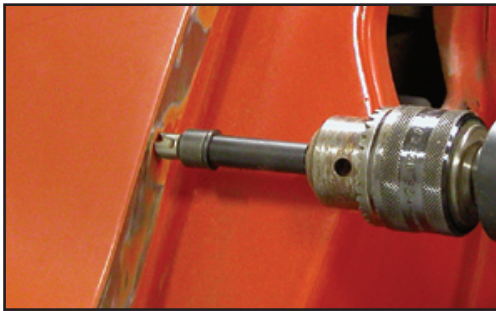

When you have a lot of spotwelds to remove, step up to the Premium Spotweld Cutters for longer life in auto body repair and restoration. These cutters have a heavier wall (.090") for extreme durability and two step geometry that splits the chips and helps clear them. Premium Spotweld Cutters have a fast cutting action and lasts for hundreds of spotwelds. They are for use in 3/8" or larger drill chucks. The spotweld cutters are available individually or in kits containing 3 cutters. (See page 7 for Spotweld Kits). Made in USA.

11093 Replacement Parts: Arbor - 11123, Pilot - 11097

11094 Replacement Parts: Arbor - 11122, Pilot - 11121

3/8" Premium Spotweld Replacement Cutters
Part No. 11108-3



Two types to choose from:

Premium Spotweld Cutter
w/ Standard Pilot
Part No. 11094



Skip-Proof Premium Spotweld Cutter
Part No. 11093

BLAIR SPOTWELD CUTTER



3/8" Double-End Replacement Spotweld Cutters Part No. 13214



Blair Double-End Spotweld Cutters make removing body panels fast and easy. Their hollow design cuts around the spotweld so weld hardness does not affect tool sharpness. When one end becomes dull, simply unscrew the cutter and flip it over using the new teeth on the other side. An adjustable depth rod sets the tool so only the outer panel is cut, leaving the underlying panel undamaged. Made in USA. Replacement Parts: Arbor - 13216, Pilot - 13217.

Blair Double-End Spotweld Cutter
Part No. 13224





Low Cost Sheet Metal Holemaking

When you don't have a lot of holes to make, Blaircutters provide fast, accurate holes in materials up to 3/16" thick. Blaircutters are annular cutting tools that cut around the edge of the hole and eject the center as a slug. Because they're hollow there's no dead zone as with twist drills. And unlike hole saws, that rip and tear through the material, they quickly give you a quality, virtually burr-free hole. Blaircutters are available in seven sizes for 1/4" and larger drill chucks. Spring loaded pilot "pops" the slug from the cutter. Made in USA.

Blaircutters are sold in 3 packs and are available in a kit Part No. 13218

BLAIRCUTTER®

Diameter (Inches)	Decimal Equivalent	Part Number
3/16" D.O.C.		
1/4	.2500	13200
5/16	.3125	13202
3/8	.3750	13204
7/16	.4375	13206
1/2	.5000	13208
9/16	.5625	13210
5/8	.6250	13212

Arbor & Pilot

Part Number	Description
13216	1/4" Blaircutter Arbor w/ retractable pilot
13217	Pilots - 3 Pack



Carbide Holcutters cut smooth, fast, burr-free holes in all types of materials, from soft aluminum to tough-to-cut stainless and cast iron, up to 1/8" thick. Dramatically outlasts bi-metal hole saws and step drills. (All cutters include arbor, pilot and spring.)

HOLCUTTER™

Diameter (Inches)	Decimal Equivalent	Part Number
Replacement Pilot (14701) Spring (14703)		
11/16	.6875	14722
3/4	.7500	14724
13/16	.8125	14726
7/8	.8750	14728
15/16	.9375	14730
1	1.0000	14732
1-1/16	1.0625	14734
1-1/8	1.1250	14736
1-3/16	1.1875	14738
1-1/4	1.2500	14740
1-5/16	1.3125	14742
1-3/8	1.3750	14744

Diameter (Inches)	Decimal Equivalent	Part Number
1-1/2	1.5000	14748
1-5/8	1.6250	14752
1-3/4	1.7500	14756
2	2.0000	14762
2-1/8	2.1250	14766
2-1/4	2.2500	14768
2-3/8	2.3750	14772
Replacement Pilot (14702) Spring (14704)		
2-1/2	2.5000	14774
2-5/8	2.6250	14778
2-3/4	2.7500	14780
3	3.0000	14784



For large holemaking in sheet metal and other materials up to 1/8" thick.

Made from high speed steel with precision cutting teeth, lasts **3x** longer and cuts **10x** faster than bi-metal hole saws or twist drills. All cutters use a single arbor, with a patented Quad-Lead thread mounting system (sold Separately). Made in USA.

Holcutter Kit contains six popular sizes of cutters... Part No.14006

Diameter (Inches)	Decimal Equivalent	Part Number
Use Arbor 14609 • 1/8" D.O.C.		
11/16	.6875	14622
3/4	.7500	14624
13/16	.8125	14626
7/8	.8750	14628
15/16	.9375	14630
1	1.0000	14632
1-1/16	1.0625	14634
1-1/8	1.1250	14636
1-3/16	1.1875	14638
1-1/4	1.2500	14640
1-5/16	1.3125	14642
1-3/8	1.3750	14644
1-7/16	1.4375	14646
1-1/2	1.5000	14648
1-9/16	1.5625	14650
1-5/8	1.6250	14652
1-11/16	1.6875	14654
1-3/4	1.7500	14656
1-7/8	1.8750	14660
2	2.0000	14662

Diameter (Inches)	Decimal Equivalent	Part Number
2-1/16	2.0625	14664
2-1/8	2.1250	14666
2-1/4	2.2500	14668
2-3/8	2.3750	14672
2-1/2	2.5000	14674
2-9/16	2.5625	14676
2-5/8	2.6250	14678
2-3/4	2.7500	14680
2-7/8	2.8750	14682
3	3.0000	14684

Arbors & Pilots

Part Number	Description
14609	Arbor for Quad-Lead Holcutter w/ washer & pilot
14601	Arbor for 11/16" - 1-5/16" Old Style Holcutter
14604	Arbor for 1-3/8" - 3" Old Style Holcutter
14610	Pilot for 14609 arbor
14611	Hex Washer for 14609 arbor
11097	Pilot for 14601 Arbor
13306	Pilot for 14604 Arbor

PAINT SHAKER

Part No. 51000 (120V)
51100 (230V)

Blair Tornado II™, The Truly Portable Paint Shaker That Doesn't Need To Be Bolted Down.

Blair Tornado II™ Paint Shakers can be set on a work bench without being bolted down thanks to its unique design.

- The Tornado II mixes paints completely utilizing three axis of motion, including orbital, side-to-side, and up/down.
- To achieve these multiple motions, the portable shaker spins an eccentric weight rather than using crankshafts, belts, or pulleys which can wear out and break.
- Lightweight at only 24 lbs (10.9 kg).
- Made in USA.

You can use Blair Tornado II Paint Shakers anywhere* it's convenient to mix gallons, quarts, pints, or aerosols.

- The fewer moving parts also minimizes noise while the paint shaker is in operation.
- A quick and easy to use four point clamping system that securely holds containers during mixing.
- Blending cycles can be set to numerous time intervals via the convenient up-front control panel.
- One year warranty
- 26" H x 15-3/8" W x 11-1/2" D (660mm H x 391mm W x 292mm D)
- Can/Paint weight limit: 11 lbs (5kg)



Part Number	Description
51027	Upper Set of (4) Springs
51028	Lower Set of (4) Springs
51032	Top Hold Down Knob
00980	Hold Down Kit (Sidebar, Screw Assy & Top Bar)

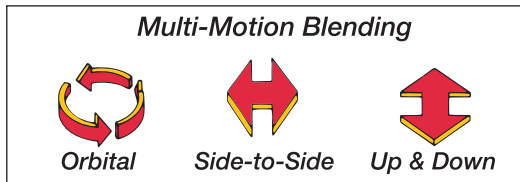

*Tornado II is not explosion proof. Do not use in areas that could be hazardous.

ACCESSORIES

Flanger



Part No. 13229



- Now with 50% additional clearance for producing a radius.
- Repairs made in half the time with absolutely no stretching or distortion of material.
- Makes a perfect joint even through underbody deadener in sculptured contours and high crowns.
- No need to remove parts of the vehicle - with the Blair Flanger, all work is performed from one side.
- Lightweight 7" cam action flanger springs open for quick release and position of next compression.
- Made in USA.

Rotabroach® Stick Lubricant



Part No. 11750

Convenient 1.68 oz. tube is ideal for sheet metal hole cutters. Softer than standard stick lubricants, it provides superior adhesion to the tool and can be used in place of cutting fluids with ferrous and non-ferrous metals, to increase tool life, improve cutting performance, & easier slug removal. Made in USA.

CUTTER KITS



Rotabroach® Cutter Kit

Part Number	Description
11090	5/16, 3/8, 7/16, 1/2, 9/16, 5/8, & 3/4" Cutters, Arbor (11122), Hex Wrench, Center Punch, & Extra Pilot
11092 (Metric)	8, 10, 12, 14, 16, 18, & 20mm Cutters, Arbor (11122), Hex Wrench, Center Punch, & Extra Pilot
11099	16 sizes (1/4 - 3/4") Cutters, Arbor (11122), Hex Wrench, Center Punch, & Extra Pilot
11201 (Metric)	16 sizes (6mm - 20mm) Cutters, Arbor (11122), Hex Wrench, Center Punch, & Extra Pilot



Rotabroach® Large Diameter Cutter Kit

Part Number	Description
11091	7/8, 1, 1-1/8, 1-1/4, 1-3/8, & 1-1/2" Cutters, Arbor (11007), Hex Washer, Center Punch, & Extra Pilot



Rotabroach® Combo Cutter Kit

Part Number	Description
11320	Combines the 11090 & 11091 into one kit. Contains 13 different sizes of cutters, (2) arbors, extra pilots, center punch & hex wrench.



Holcutter™ Kit

Part Number	Description
14006	7/8, 1-1/8, 1-3/8, 1-3/4, 2, 2-1/2" Cutters, Arbor, Hex Washer, & Extra Pilot
14003	3/4, 1, & 1-1/4" Cutters, Arbor & Extra Pilot Drills



Spotweld Cutter Kits

Part Number	Description
11082	(3) 3/8" Cutters, Arbor (11122) w/ Standard Pilot & Extra Pilot
11096	(3) 3/8" Cutters, Arbor (11123) w/ Skip-Proof Pilot, & Extra Pilot
11098	(3) 5/16" Cutters, Arbor (11122) w/ Standard Pilot & Extra Pilot



Rustproof/PDR Kits

Part Number	Description
11080	1/4, 3/8, 1/2, & 3/4" Cutters, Arbor w/ Standard Pilot, & Extra Pilot
11081	(3) 1/2" Cutters, Arbor (11122) w/ Standard Pilot, & Extra Pilot
11095	(3) 1/2" Cutters, Arbor (11123) w/ Skip-Proof Pilot, & Extra Pilot



Blaircutter® Kit

Part Number	Description
13218	1/4, 5/16, 3/8, 7/16, 1/2, 9/16 & 5/8" Cutters, Arbor, & (3) Extra Pilots



Blair body shop tools are used by collision and custom shops around the world to make auto body repairs, aftermarket installations, and custom fabrication easier, faster, more accurate and more profitable. No matter if its Rotabroach® Cutters, Holcutter™, or Spotweld Cutters, Blair makes holes faster and with superior quality. Make body repairs that exceed those off the assembly line, keeping with the high standards of today's automotive market.

The world of custom hotrods and motorcycles is bigger than ever and whether you're a top fabricator or weekend warrior, you need the tools to express your creativity. Blair tools can help turn those ideas into a reality. Holemaking in sheet metal has never been easier. Plus, use the Blair Flanger to make perfect overlapping joints to weld panels, or the Tornado II Portable Paint Shaker to mix your paint to the right consistency.

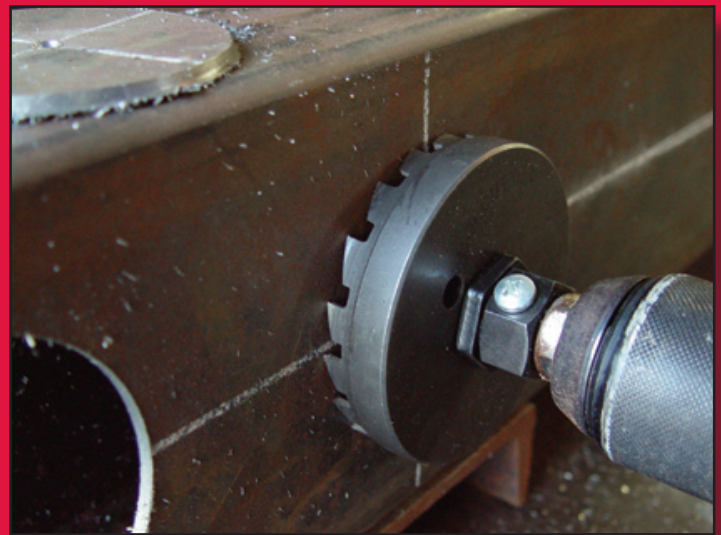

Blair™

Learn more about paint and body repair we have.