

Pulling Post Kit

Operating Instructions & Parts Manual

Model Number B93601B

Items included:

- B93600B • 10 Ton Pulling Post
- B65428 • Air Pump with Hose
- B65444 • 10 Ton 10" Stroke Ram
- B97662 • Chain & Claw Hooks (2pc.)
- B97691 • Chain & Grab Hook

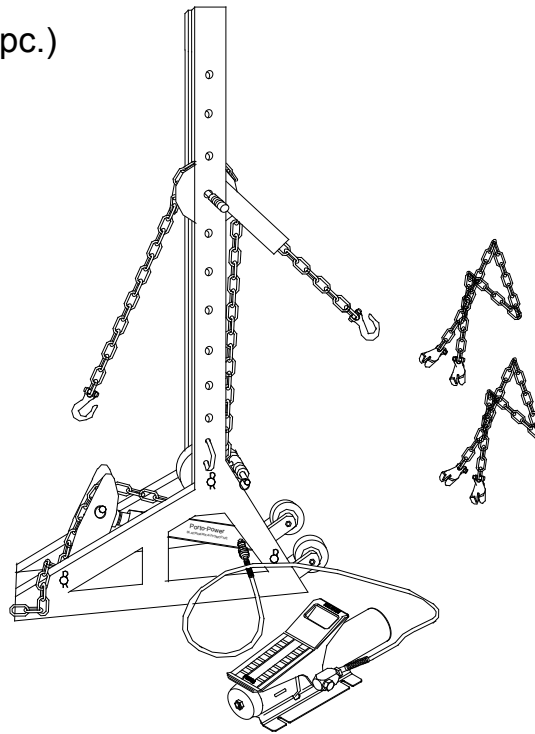

This is the safety alert symbol. It is used to alert you to potential personal injury hazards. Obey all safety messages that follow this symbol to avoid possible injury or death.

Read this manual and follow all the Safety Rules and Operating Instructions before using this product.

SAFETY and GENERAL INFORMATION

Save these instructions. For your safety, read and understand the information contained within. The owner and operator shall have an understanding of this product and safe operating procedures before attempting to use this product. Instructions and safety information shall be conveyed in operator's native language before use of this product is authorized. Make certain that the operator thoroughly understands the inherent dangers associated with the use and misuse of the product. If any doubt exists as to the safe and proper use of this product as outlined in this factory authorized manual, remove from service immediately.

Inspect before each use. It is recommended that, prior to each use, an inspection be done by qualified personnel and that any missing or damaged parts, decals, warning/safety labels or signs be replaced with factory authorized replacement parts only. Any part that appears to be damaged in any way, is worn, leaking or operates abnormally shall be removed from service immediately until such time as repairs can be made. Owners and operators of this equipment shall be aware that the use and subsequent repair of this equipment may require special training and knowledge. If any component of this product has been or suspected to have been subjected to a load dropped suddenly, unexpectedly upon it, discontinue use until checked out by a Porto-Power Blackhawk Automotive Authorized Service Center. Labels and Operator's Manuals are available from manufacturer.

PRODUCT DESCRIPTION

Porto-Power Pulling Post Kit is designed for rated capacity lifting and pulling jobs. This kit includes a pulling post frame (B93600B), a 10,000 psi air pump with hose (B65428), a 10 ton 10 inch stroke threaded ram (B65444), a 9-foot chain with grab hook (B97691), and two 6-foot chain with two claw hooks (B97662). This pulling post can be used with common pot patterns or new chainless anchor system. Building Block design lets users create their own custom pull system. A wide variety of applications exist for this category of product. Special skill, knowledge and training may be required for a specific task and the product may not be suitable for all the jobs described above. Unsuitable applications would include applications that call for a device to move, level or support persons, animals, hazardous materials, mobile homes/ dwellings in general, mirrors and/or plate glass, and/or to connect/secure hatches, components, etc. between bulkheads. The user must ultimately make the decision regarding suitability of the product for any given task and assume the responsibility of safety for himself and others in the work area.

 *Always check connections before using. Alteration of these products is strictly prohibited. Use only those adapters and attachments provided and approved by the manufacturer.*

 **WARNING:** *To reduce the risk of personal injury and/or property damage, ensure that the rated working pressure of each pressurized attachment be equal to or greater than the rated working pressure developed by the hydraulic pump.*

SPECIFICATIONS

Model	Capacity (ton)	Pulling Post frame			Air Pump		Ram				
		Height (in)	Base Size (in)	Floating Pulley Position	Usable Oil Capacity (in ³)	Input Air Pressure (psi)	Stoke (in)	Effective Area (in ²)	Oil Capacity (in ³)	Min. Height (in)	Operating Pressure (psi)
B93601B	10	59	27 x 20	10	36.6	90-175	10	2.24	22.4	15.63	8950

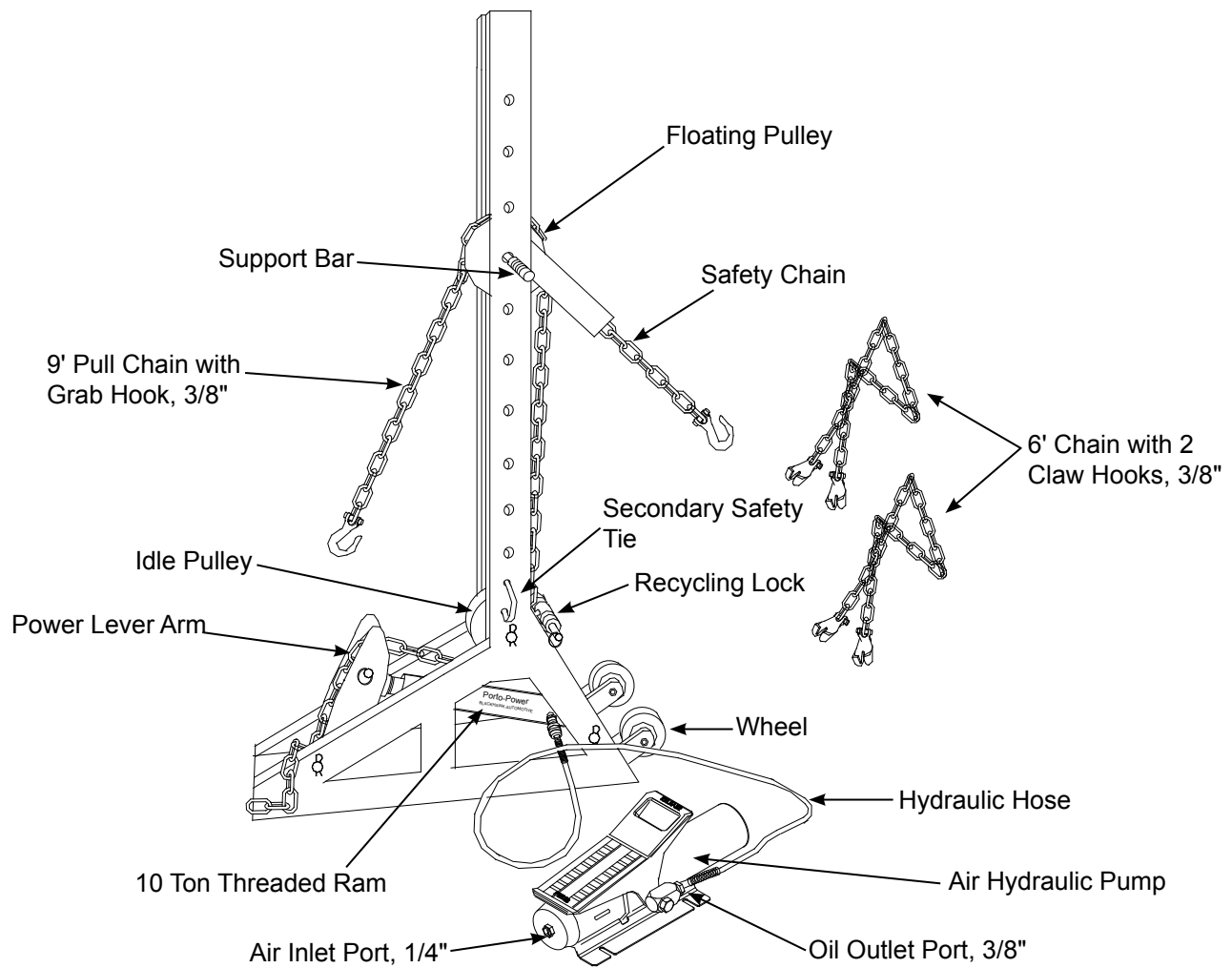

Figure 1 - B93601B Components

BEFORE USE

1. Study, understand, and follow all instructions provided with and on this device before use.
2. Inspect before each use. Do not use if bent, broken, leaking or damaged components are noted.
3. Ensure that product and application are compatible.
4. Ensure that all parts of your kit are included.
5. Connect hose coupler to ram coupler, ensure that there are no fluid leaks.
6. Ram should be stored in the vertical position.

SET UP

⚠ *Install a pressure gauge on your pump to monitor the system pressure. Do not exceed the system rated pressure, 8950 psi.*

1. Secure the threaded ram to bottom of puller post, then connect ram to air pump with hydraulic hose provided.
2. Slide the 9-foot pull chain thru the floating pulley, idle pulley and power lever arm.
3. Secure the safety chain on floating pulley to an anchor pot or between two anchor pots using 6 feet claw hooks chain.

Note: The dual chain helps to divide the pull force exerted by the post and also allows positioning the post between two anchor pots.

⚠ WARNING



- Study, understand, and follow all instructions provided with and on this device before use.
- All WARNING statements must be carefully observed to help prevent personal injury.
- No alteration shall be made to this device.
- Always wear protective gear when operating hydraulic equipment.
- Keep hydraulic equipment away from flames and heat. Hydraulic fluid can ignite and burn. Do not operate if leaks are detected.
- **Crush Hazard.** Keep hands and feet away from loading area. Avoid pinch points or crush points that can be created by the load, cylinder, or any equipment of system.
- To avoid crushing and related injuries: NEVER work on, under or around a lifted load before it is properly supported by appropriate mechanical means. Never rely on hydraulic pressure alone to support load.
- Do not use the safety chain under floating pulley as a "pull" chain.
- On severe pulls, use secondary safety ties, strap and blankets around chains.
- Do not pull chain over sharp corners. Use protective pads.
- Listen for popping noises indicating weld fractures and possible sudden separation.
- Avoid sudden jerks when applying tension to chain.
- Never use chain assemblies not intended for collision repair equipment.
- The chain/hooks must be 3/8" trade size, heat treated, alloy type rated for "collision repair" applications.
- Do not cut chain with cutting torches. Heat will degrade chain.
- Remove damaged, kinked, twisted, stretched or rusty chain from service so it cannot be accidentally reused.
- Monitor pressure and load at all times. Always verify load with calibrated load cell and indicator, or pressure gauge.
- If the load is lifted, use blocking and cribbing to guard against a falling load.
- All personnel must be clear before lowering.
- Never try to disassemble a ram or pump. Refer repairs to qualified, authorized personnel.
- Do not modify this device.
- When the ram is not in use, keep ram fully retracted.
- Failure to heed these markings may result in personal injury and/or property damage.

Pulling Post

- Use only on hard, level surfaces capable of sustaining rated capacity loads.
- For safety, operate equipment at least 6 feet from either side of post and chains.
- Do not stand behind post, chain and clamps when under load.

OPERATION

Note: The pull post is operated by a 10 Ton 10 inch stroke hydraulic ram attains 20,000 pounds of pull on the chain at 8950 psi pressure.

⚠ Operate equipment from at least 6 feet from either side of post and chains.

⚠ ALWAYS monitor pressure, load or position using suitable equipment. Pressure may be monitored by means of an optional manifold and gauge. Load may be monitored by means of a load cell and digital indicator. Correct application position can only be determined by the operator of the equipment.

1. Adjust the floating pulley to desire height to pull using the handle bar. For low pull, pull without floating pulley, just slide thru the idle pulley.
2. Connect air nipple (not included) to air input port before connecting air hose.
3. Connect to suitable air supply, ensure air input pressure range from 110 to 175 psi.
4. Secure the pull chain before pulling object.
5. To operate, press the foot pedal of air pump until desire height or position is reached. Always monitor pressure and load. Do not exceed 8950 psi and use caution when nearing this maximum operating ram pressure.

Caution! Never operate pump with hose disconnected from ram. If operated in this condition, the hose and connections become pressurized. This increases burst hazard. Damage may occur to pump and its components

6. To release, simply press the release valve by stepping on the raised, stirrup shaped portion of the foot pedal.
7. Figure 2 below shows illustrations of common applications.

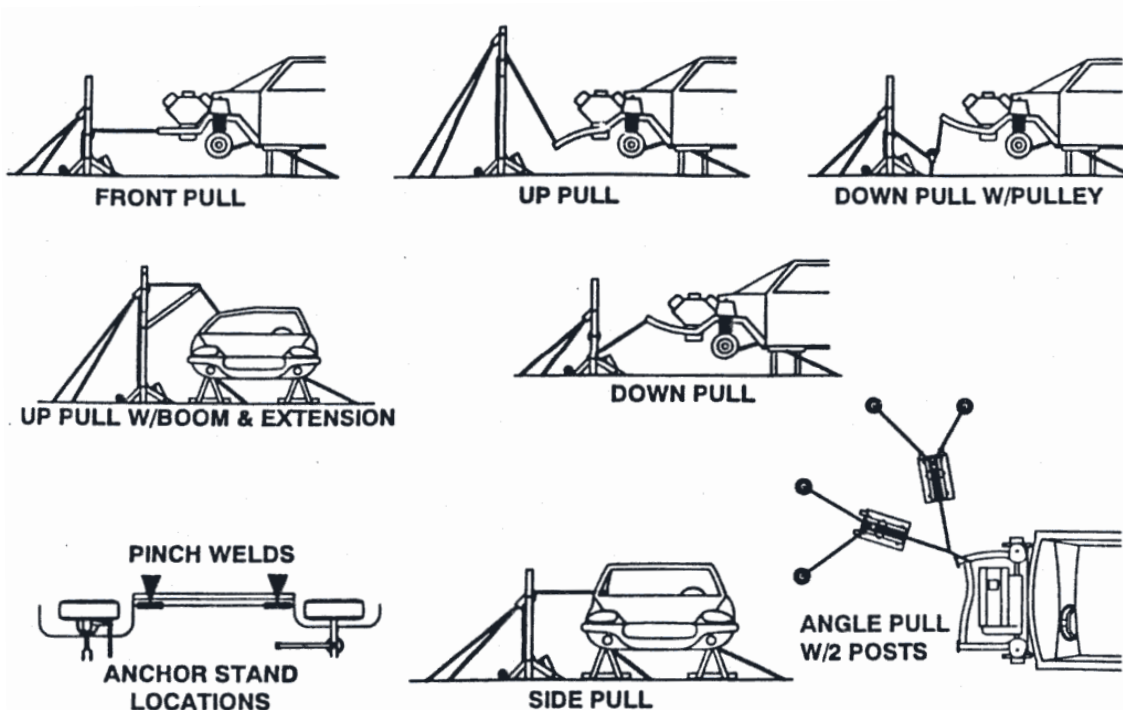

Figure 2 - Illustrations of different methods for pulling application

MAINTENANCE

1. Inspect and replace damaged, kinked, twisted, stretched or rusty chain.
2. Inspect hoses and connections. Replace damage components immediately with Porto-Power Blackhawk replacement parts only.
3. Tighten connections as needed. Use non-hardening pipe thread compound when servicing connections.
4. Use only good quality hydraulic fluid. We recommend Hein-Werner HW93291 or equivalent.

Lubrication

Use a light machine oil to lubricate pivot points, hinges and all joints of post that move under heavy load.

Adding Hydraulic Fluid

1. Depressurize and disconnect hydraulic hose from application.
2. With pump in its vertical position, remove the reservoir cap located on the reservoir.
3. Use a small funnel to fill reservoir to within 3/4" (19mm) of the opening.

Note: Use only a good quality hydraulic jack fluid. **Never** use brake fluid, transmission fluid, turbine oil, motor oil, alcohol, glycerin etc. Use of other than good quality hydraulic oil will void warranty and damage the pump, hose, and application.

4. Wipe up any spilled fluid. Reinstall the reservoir cap.

Changing Hydraulic Fluid

For best performance and longest life, replace the complete fluid supply at least once per year.

1. Depressurize and disconnect hydraulic hose from application.
2. Repeat #2 above, then pour used fluid into a sealable container.
4. Use a small funnel to fill reservoir to within 3/4" (19mm) of the opening.
5. Dispose of fluid in accordance with local regulations.
6. Fill with a good quality hydraulic oil as recommended above. Reinstall reservoir cap.

Storage

1. Depressurize and disconnect hydraulic hoses from ram.
2. Wipe clean and store in dry environment. Avoid extreme temperatures.

TROUBLESHOOTING

Symptom	Possible Causes	Corrective Action
Ram will not extend	<ul style="list-style-type: none"> • Overload condition 	<ul style="list-style-type: none"> • Remedy overload condition
System does not maintain pressure	<ul style="list-style-type: none"> • Hydraulic unit malfunction 	<ul style="list-style-type: none"> • Replace ram and / or pump
Ram does not return fluid to pump (i.e. ram will not retract)	<ul style="list-style-type: none"> • Reservoir overfilled • Ram damage • Malfunctioning coupler, damaged application. 	<ul style="list-style-type: none"> • Drain fluid to proper level • Replace ram • Secure load by other means. Depressurize pump and hose, remove coupler and/or application, then replace with a new one.
Poor performance	<ul style="list-style-type: none"> • Fluid level low • Air trapped in system 	<ul style="list-style-type: none"> • Ensure proper fluid level • With ram fully retracted, remove oil filler screw to let pressurized air escape, then reinstall oil filler screw
Will not lift to full extension	<ul style="list-style-type: none"> • Fluid level low 	<ul style="list-style-type: none"> • Ensure proper fluid level

REPLACEMENT PARTS

Please refer to the Parts drawing when ordering parts. Not all components are replacement items, but are illustrated as a convenient reference of location and position in the assembly sequence. When ordering parts, give model no., serial no. and description below.

Item#	Part#	Description	Qty
1	600-001-100B	Recycling Lock	1
2	600-001-201B	Heel Block	1
3	600-001-203B	Floating Pulley	1
5	600-001-206B	Idle Pulley	1
6	600-001-213B	Bar, D3/4"x5-1/2"	1
7	600-001-208B	Bar with pins, D3/4"x8"	3
8	600-001-209B	Bar with Handle Grip, D3/4"x11"	2
9	600-001-210B	Rubber Wheel Assembly (Dia. 4")	2
10	600-001-214B	Power Lever Arm (for 10" ram)	1
11	600-001-212B	Ram Coupling	1
12	B93652B	Power Lever Arm Assembly	-
13	B93600B	Puller Post Frame	1
14	B65444	Ram, 10 Ton 10" Stroke	1
15	B65582	Ram Coupler, 3/8"	1
16	B65581	Hose Coupler, 3/8"	1
17	B65426	Air Pump	1
18	B65594	Hydraulic Hose, 6' x ID3/8"	1
19	B97691	Chain with Grab Hook, 9' x ID3/8"	1
20	B97662	Chain with 2 Claw Hooks, 6' x ID3/8"	2

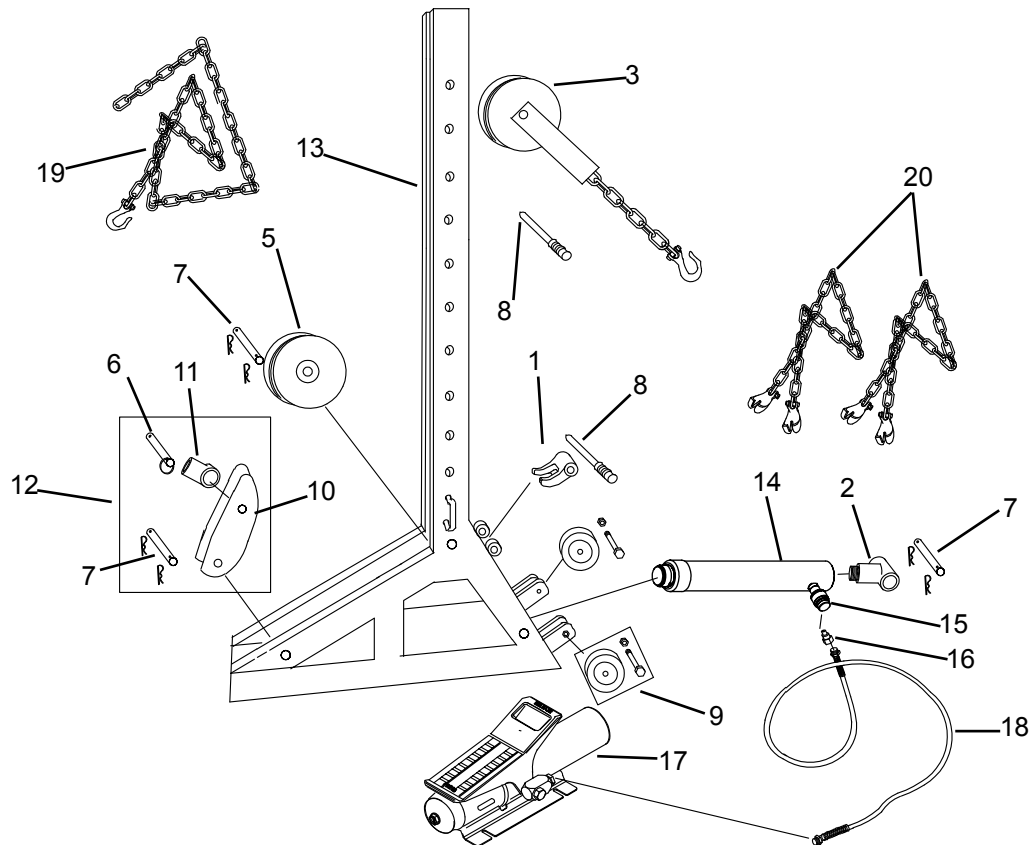

Figure 3 - Replacement Parts Illustration for B93601B

When it comes to quality automotive tools, Blackhawk Automotive is the brand you can depend on.