





Pos	Code	Description	Pcs .
1	055000101	2m workbench	4
	055000102	a) 2m worktop	1
	055000104	b) Plain right leg	1
	055000105	c) Plain left leg	1
	055000103	d) Rear support crossbeam	1
2	055000151	2m pro workbench	4
	055000102	a) 2m worktop	1
	055000154	b) Right leg with built-in roller	1
	055000155	c) Left leg with power sockets	1
	055000103	d) Rear support crossbeam	1
3	019010111	Hose reel	1
4	*	Mobile roller cab	N.d
5	*	Fixed module	N.d
6	015990150	Bench vice	N.d

<p>A</p>  <p>M8 X 16 TCEI (18 pcs.)</p>	<p>B</p>  <p>M12 X 60 (3 pcs.)</p>	<p>C</p>  <p>Washer Wide Band (6 pcs.)</p>	<p>D</p>  <p>Nuts M12 (6 pcs.)</p>
--	---	---	---



For each leg remove the side cover and the front window

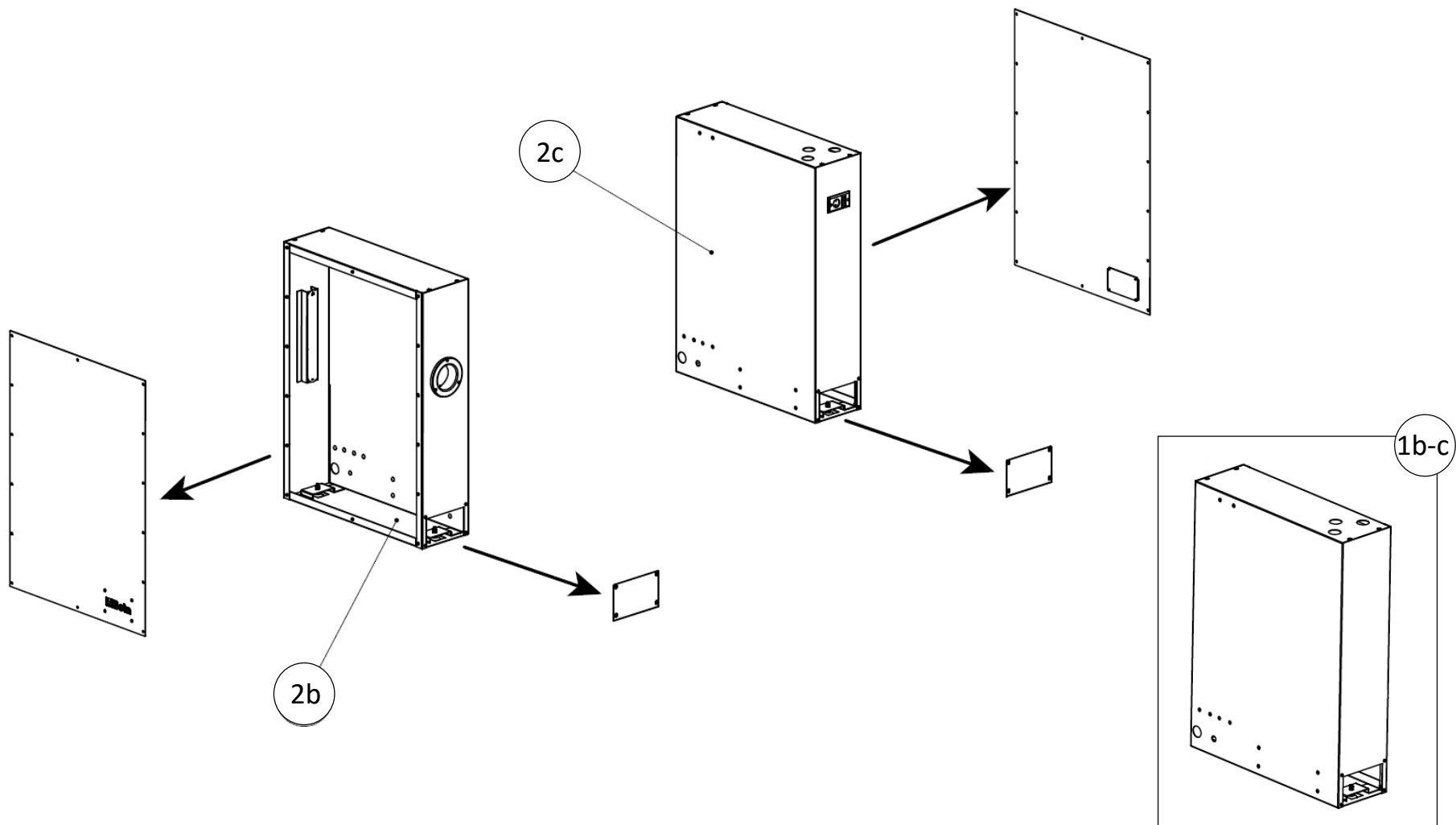
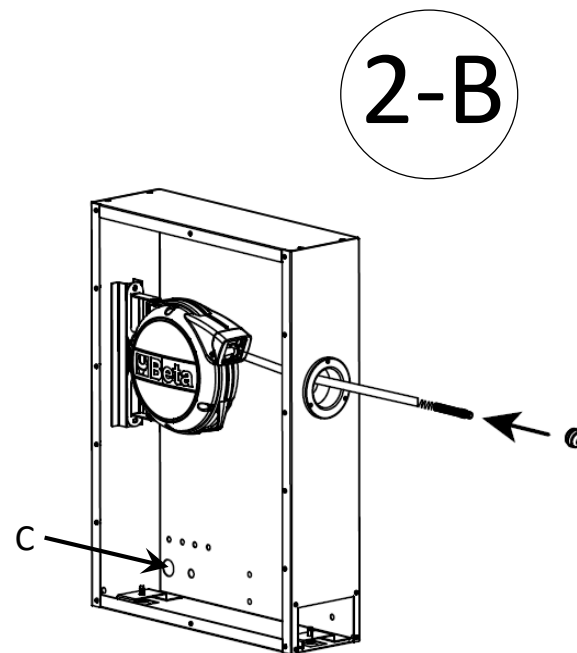
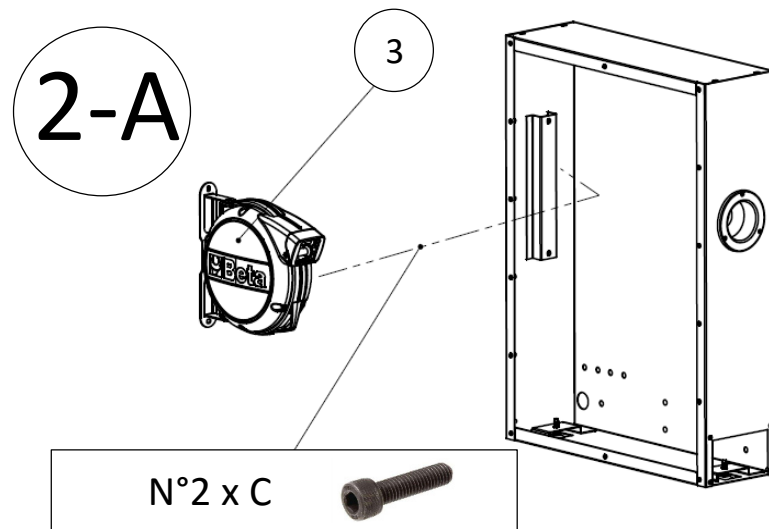

Insert the rollable end of the air hose in the front socket; pass the other one through the hole C

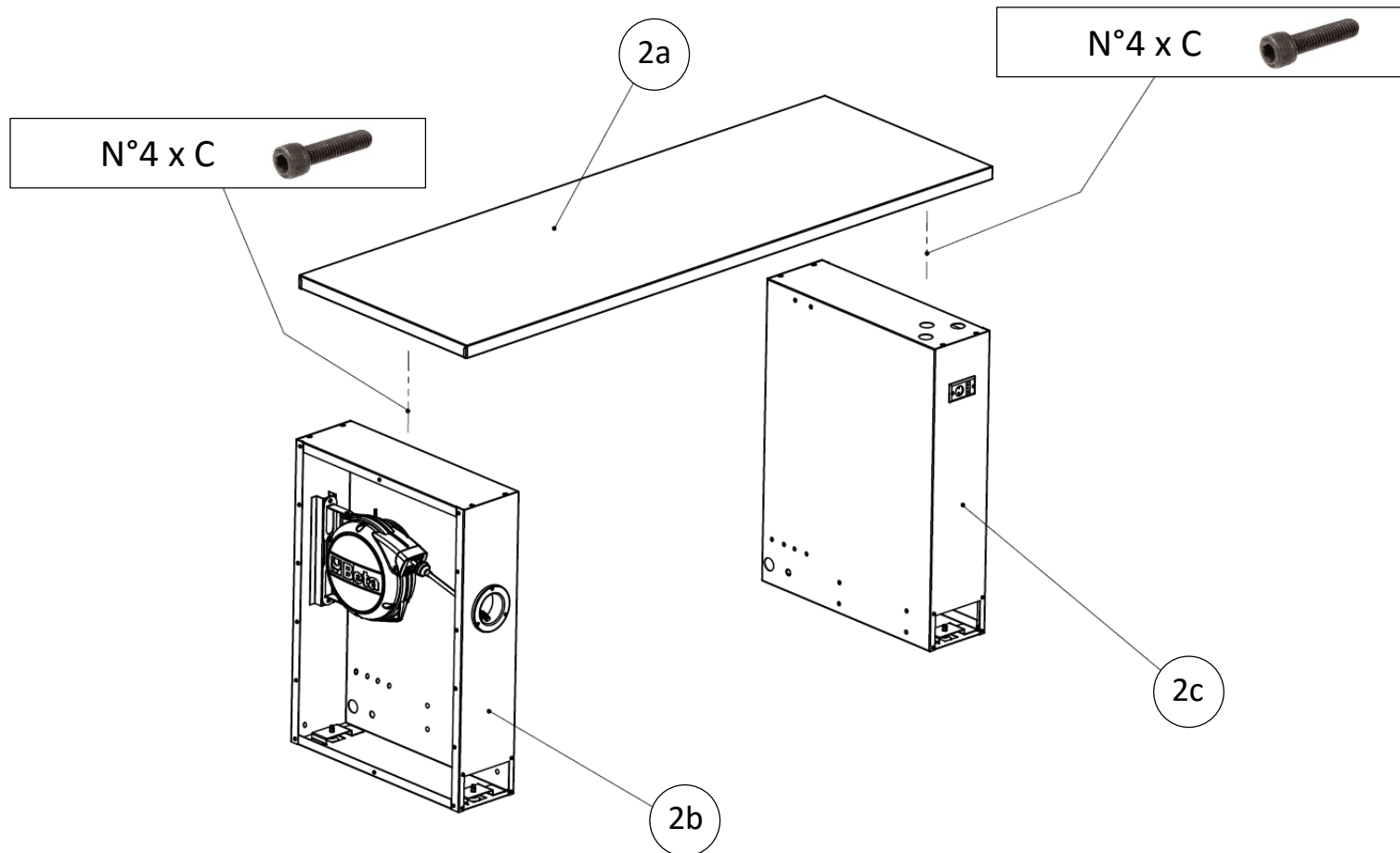

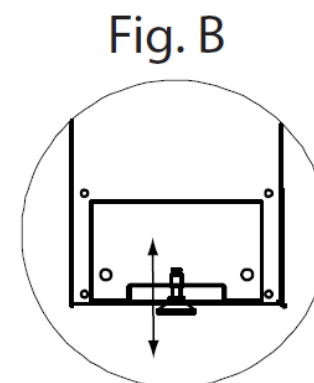
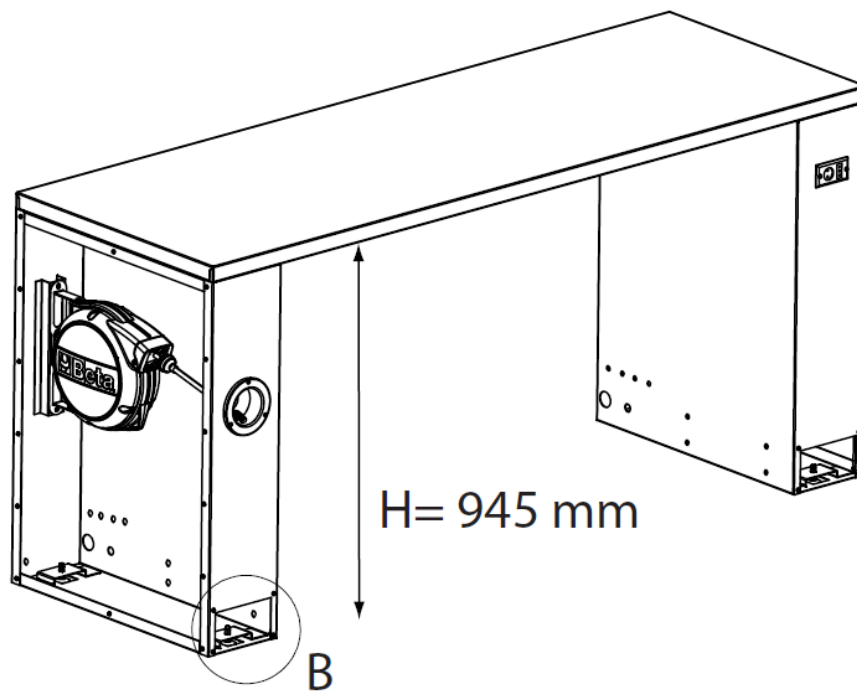

Adjust the 4 adjustable feet (Fig. B) to level the structure at the minimum height of 945 mm from the floor

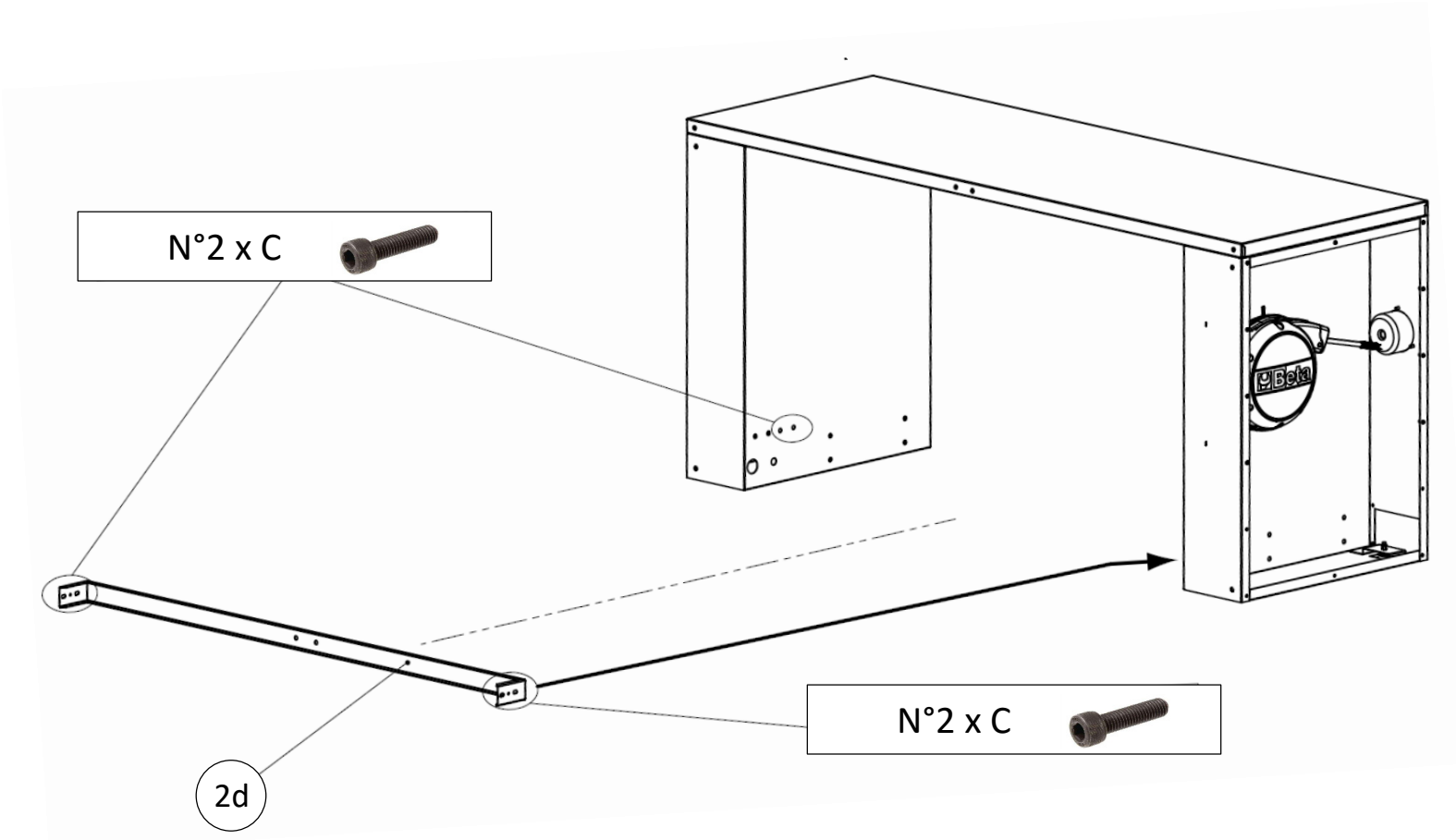

6-A

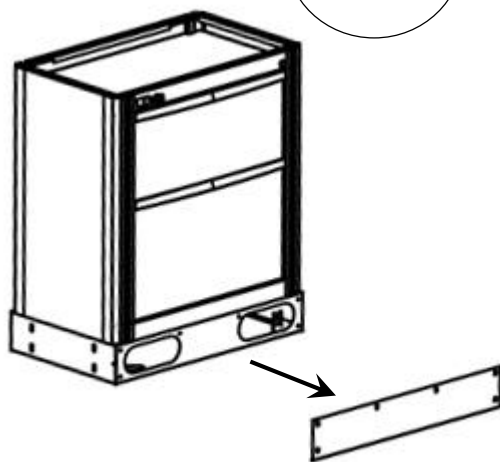

6-B

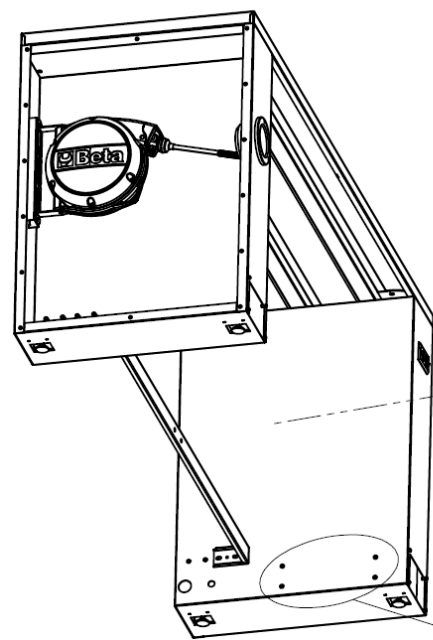

5

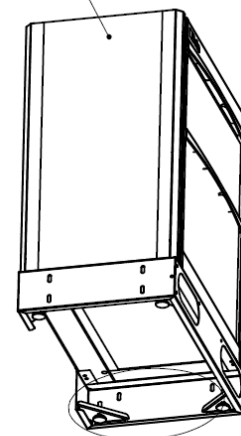

Remove the front cover of the fixed module off (6-A) . Screw it the module to the workbench leg (6-B)

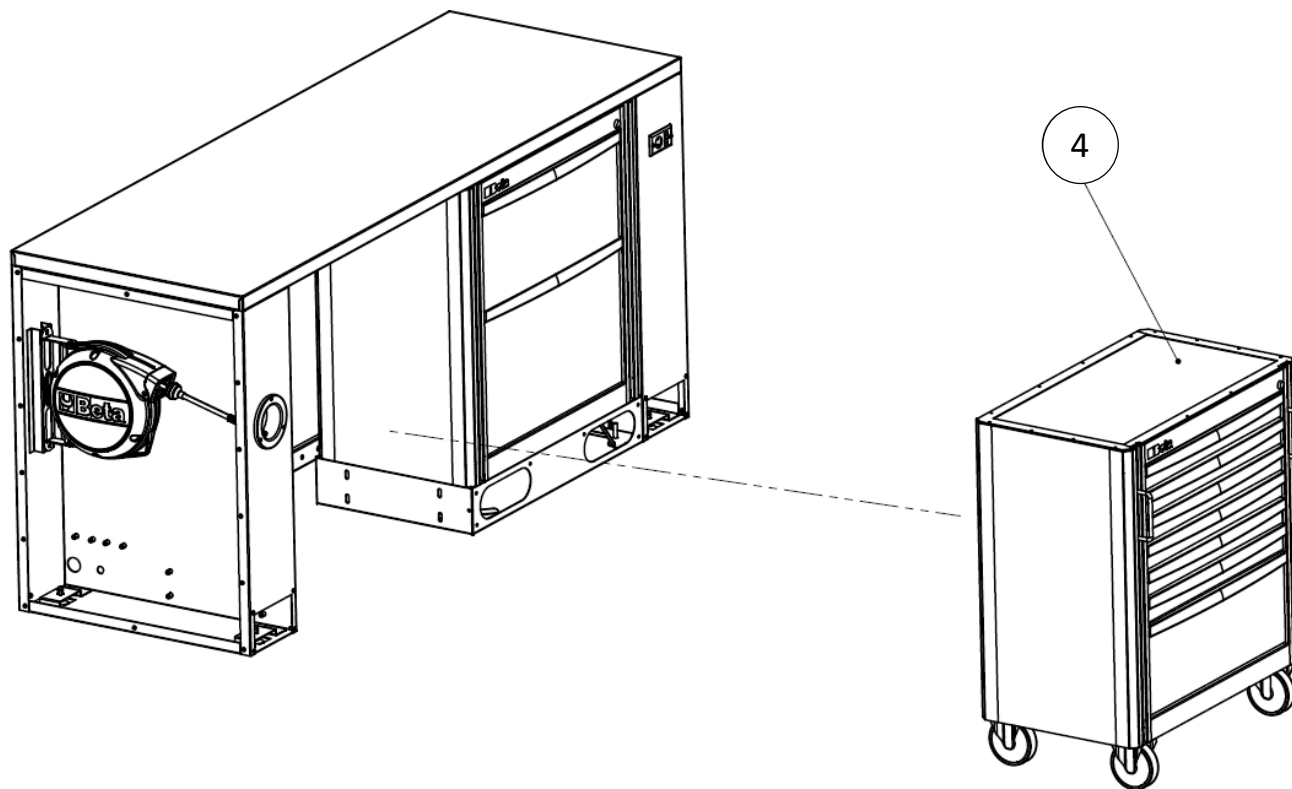

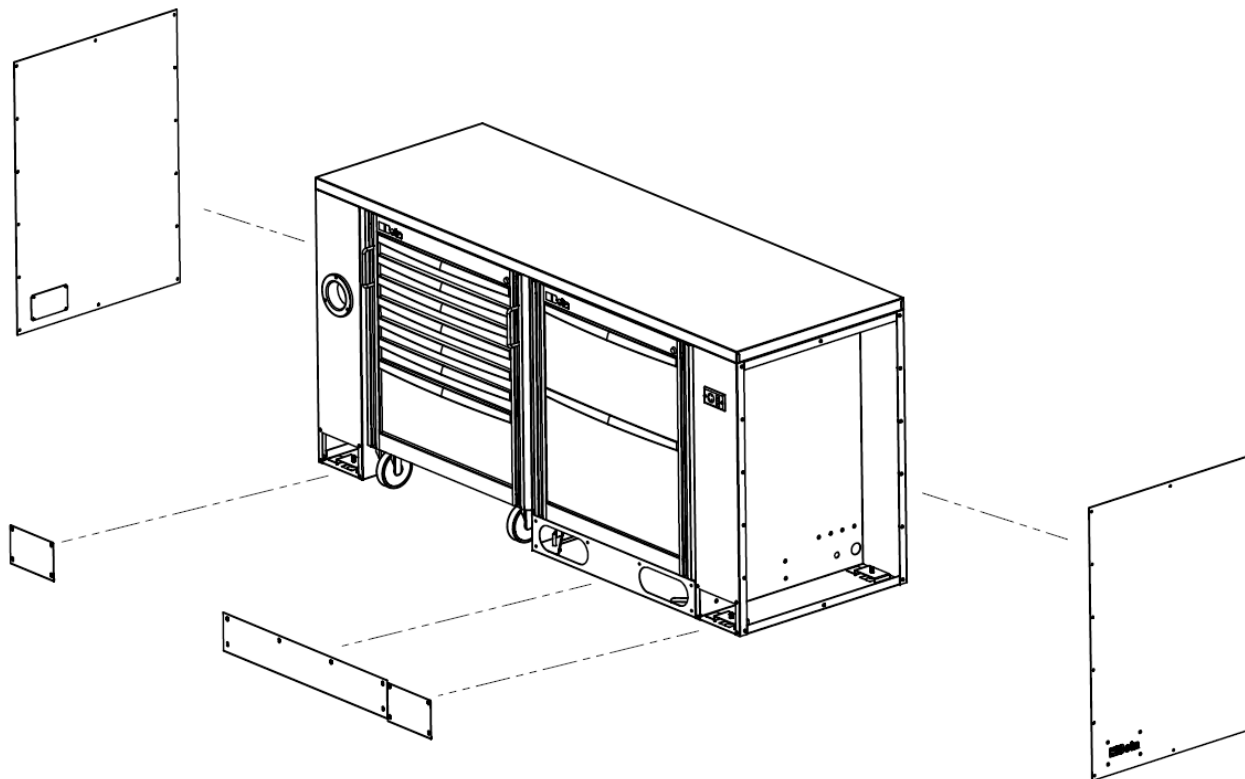

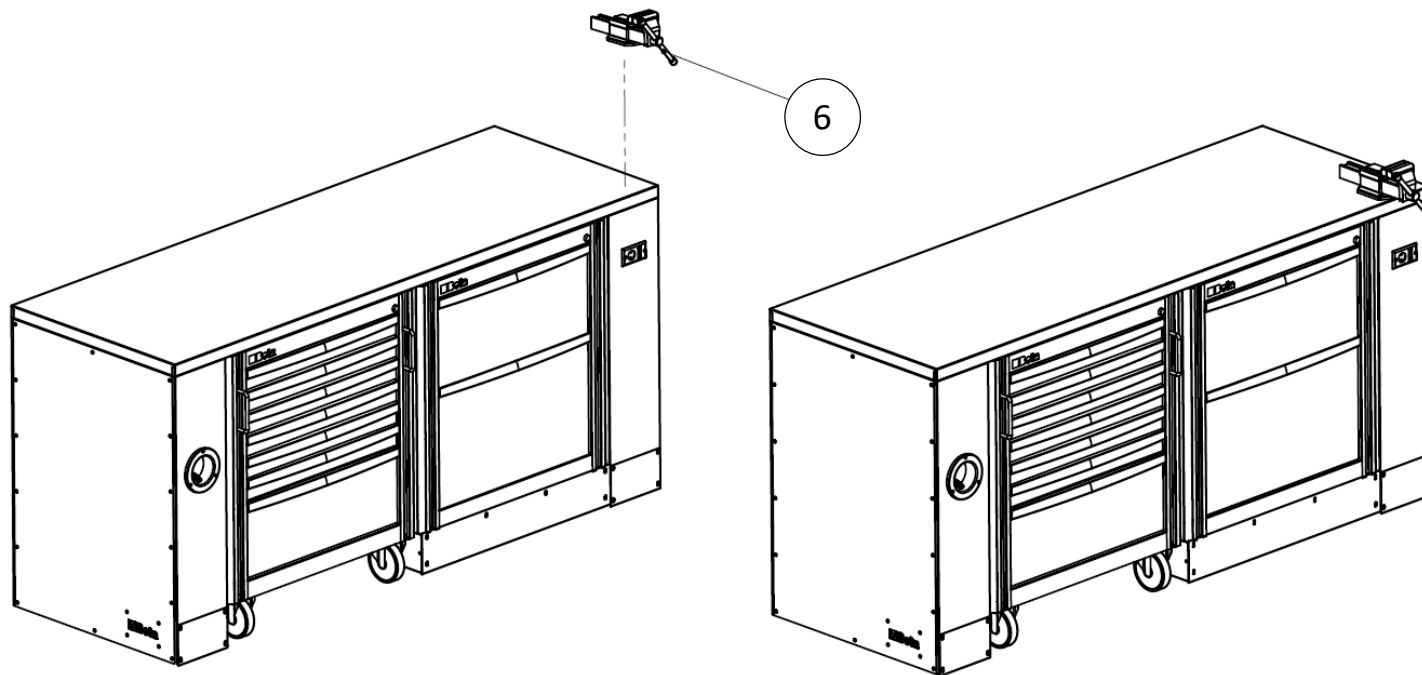

BEFORE

AFTER

9-A

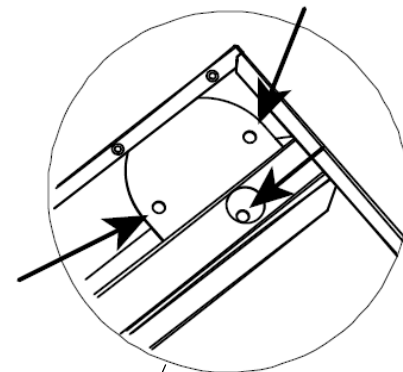
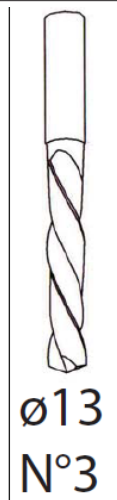
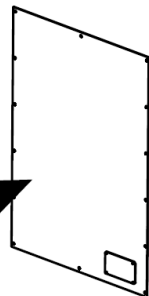
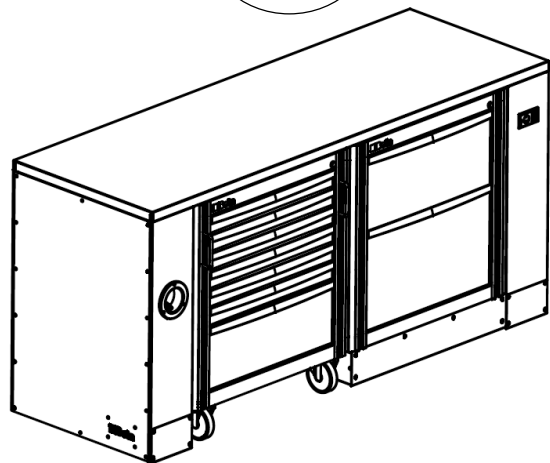

9-B

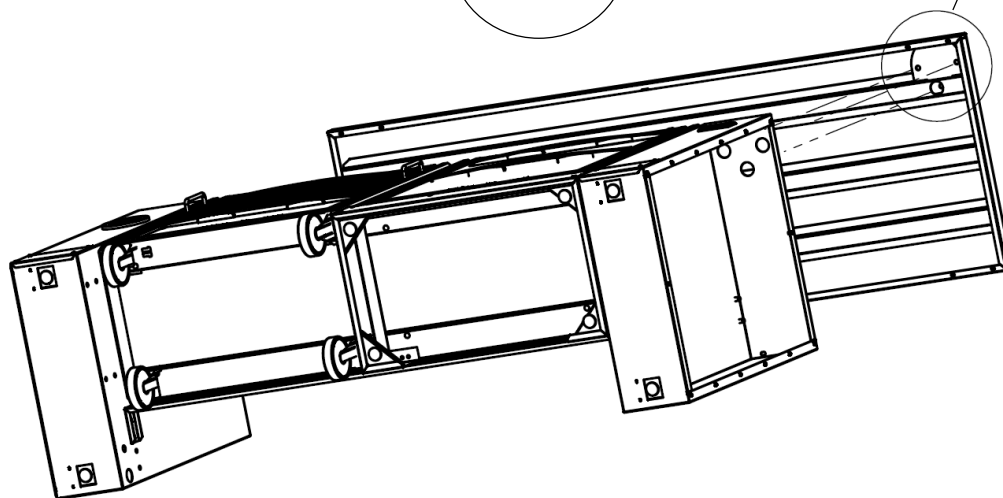

9-C

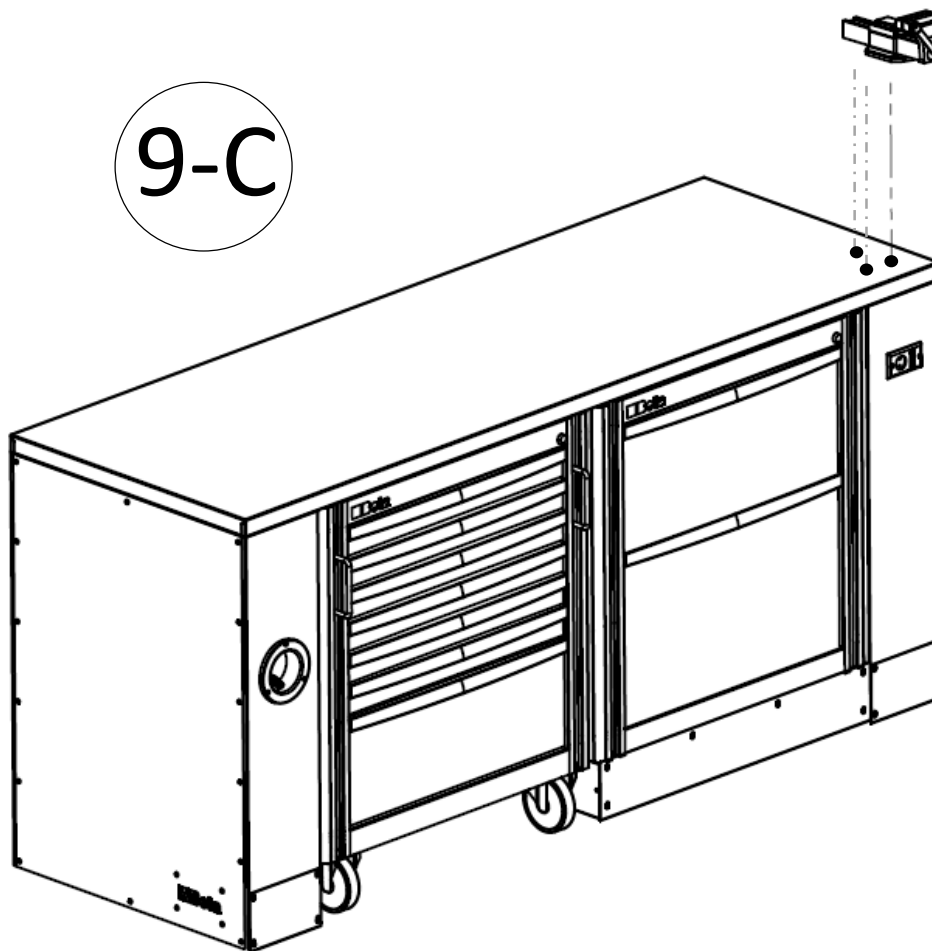

N°3 x B	
N°6 x C	
N°6 x D	