



Beta

1931CD10

Operation manual and instructions



1



2

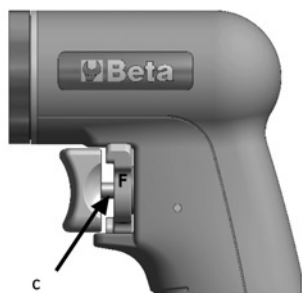

3



4

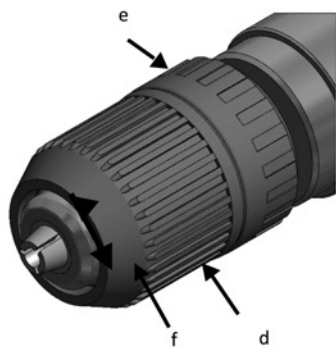

5



6

OPERATION MANUAL AND INSTRUCTIONS

EN

OPERATION MANUAL AND INSTRUCTIONS FOR AIR DRILLS MANUFACTURED BY:

BETA UTENSILI
S.P.A.

Original documentation drawn up in ITALIAN.

CAUTION



IMPORTANT! READ THIS MANUAL THOROUGHLY BEFORE USING THE PNEUMATIC TOOL. FAILURE TO COMPLY WITH THE SAFETY STANDARDS AND OPERATING INSTRUCTIONS MAY RESULT IN SERIOUS INJURY.

Store the safety instructions with care and hand them over to the users.

PURPOSE OF USE

The air drill can be used for the following purposes:

- Drilling and countersinking.
- The air drill can also be used in open places exposed to water and air.

The air drill must not be used for the following operations:

- Threading and/or tapping.
- Screwing and/or unscrewing.
- The air drill must not be used in environments containing potentially explosive atmospheres.
- The trigger must not be locked with adhesive tape or clamps.

WORK AREA SAFETY

- Beware of both surfaces that may become slippery due to the use of the machine and the danger of tripping over the air hose.
- While using the pneumatic tool for jobs performed high from the ground, take all necessary precautions, to eliminate or minimize risk to other workers, following the accidental falling of any tools (for example, isolation of the work area and proper signs).

 Do not operate the pneumatic tool in environments containing potentially explosive atmospheres, because sparks may be generated, which can ignite the dust, fumes or gases.

 Avoid contact with live equipment: the pneumatic tool is not insulated, and contact with live parts can cause electric shocks.

 To find any hidden power supply lines, use suitable search tools or contact the local power supply company. Contact with electric lines can cause fires and electric shocks. Damaging gas lines causes the risk of explosion. Penetrating a water pipe will result in severe material damage.

 Keep children and bystanders away from your workplace while operating the pneumatic tool. Distractions from other people can cause you to lose control over the pneumatic tool.

PNEUMATIC TOOL SAFETY

- Do not point the air flow to yourself or other people. Compressed air can cause serious injury.
- Check the connections and the air supply lines. All units, couplers and hoses should conform to the product specifications in terms of pressure and air volume. Too low pressure impairs the function of the pneumatic tool; too high pressure can cause damage and/or injury.
- Do not bend or tighten any hoses; avoid using solvents and sharp edges. Keep the hoses away from heat, oil and rotating parts. Immediately replace any damaged hose. A defective feed pipe may cause uncontrolled movements of the compressed air pipe. Raised dust or chips may cause eye injury. Make sure that the hose clamps are always secured firmly.

PERSONNEL SAFETY

- Stay alert; watch what you are doing. Do not use the pneumatic tool while tired or under the influence of drugs, alcohol, or medication.

• **Always use the following personal protective equipment:**

- Eye protection
- Safety shoes
- Hearing protection
- Protective gloves against physical agents
- Anti-vibration gloves, to be worn following a specially conducted survey of the daily exposure of the hand-arm system to vibration
- Protective mask against physical agents according to the values found in the environmental/industrial hygiene survey.

- Make sure you are in a safe position, keeping proper balance at all times. A safe working position and a proper body posture enable better control of the pneumatic tool in unexpected situations.
- Do not wear loose clothing or jewellery. Keep your hair, clothing and gloves away from moving parts. Loose clothing, jewellery, and long hair can get caught in moving parts.
- Do not directly inhale the exhaust air, and prevent it from getting into your eyes. The exhaust air of the pneumatic tool can contain water, oil, metal particles and impurities, which may cause hazards.

PNEUMATIC TOOL USE AND CARE

- Use clamping devices or a vice to secure and support the workpiece. Holding the workpiece by hand or against your body will not allow for safe operation of the pneumatic tool.
- Do not overload the pneumatic tool. Use the pneumatic tool intended for your work only.
- Always check that the machine is free from defects. Do not use a pneumatic tool that has a defective On/Off switch. A pneumatic tool that can no longer be stopped or started is dangerous and must be repaired.
- Disconnect the air supply before making adjustments, changing accessories, or placing the pneumatic tool aside. This safety measure prevents accidental starting of the pneumatic tool.
- Store idle pneumatic tools out of the reach of children. Do not allow persons unfamiliar with these instructions to operate the pneumatic tool.
- Maintain the pneumatic tool with care. Check for misalignment or binding of moving parts, breakage or damage of parts and any other condition that may affect the operation of the pneumatic tool. Have damaged parts repaired before using the pneumatic tool.
- Keep cutting tools sharp and clean. Properly maintained cutting tools with sharp cutting edges are less likely to bind and are easier to control.
- Do not modify the pneumatic tool. This can reduce the effectiveness of safety measures and increase operator risk.
- Have the pneumatic tool repaired only through a trained repair person and only using original replacement parts.

AIR DRILL SAFETY

- Make sure that the nameplate is readable; get a replacement nameplate from the manufacturer, if need be.
- If the cutting tool or the workpiece should break, loose parts may be thrown at high speed.
- Operators and maintenance personnel should be physically able to handle the weight and power of the pneumatic tool.
- It is important to be prepared for unexpected movements of the pneumatic tool resulting from a jammed or broken cutting tool. Maintain a firm grip on the pneumatic tool and position your body and arms to allow you to resist such movements. These precautions can prevent injuries.
- **The pneumatic tool may get jammed if:**
 - The pneumatic tool is overloaded
 - The cutting tool gets jammed in the workpiece
 - The cutting tool thoroughly crosses the work material
- Keep your hands away from the chuck and cutting tool: you may hurt yourself.
- Make sure that the direction of rotation of the air drill is fit for the cutting tool being used.
- Turn off the tool in case of air supply failure or low operating pressure. Check the operating pressure; turn on the tool again when optimal operating pressure is resumed.
- When using the pneumatic tool, the operator can experience discomfort in the hands, arms, shoulders, or neck area. Adopt a

OPERATION MANUAL AND INSTRUCTIONS

EN

comfortable posture, and avoid awkward or off-balanced postures, or change posture to help avoid discomfort and fatigue.

 **Caution:** If the pneumatic tool is used over a protracted period of time, part of the tool and the cutting tool may become hot. Wear protective gloves.

 **Dust and fumes hazards:** Depending on the type of material being worked, the fumes generated while operating the pneumatic tool can cause diseases in humans. An appropriate environmental hygiene survey is required to determine the type and degree of protection of the personal protective equipment to use for the respiratory tract.

Using the pneumatic tool on the workpiece generates noise, which may prove harmful to the exposed personnel.





A proper phonometric survey is required to determine the personal hearing protective equipment (hearing protection) to use.

 If a specially conducted survey suggests that the daily exposure to vibration generated from the pneumatic tool exceeds the limit value under the regulations in force in the respective country, anti-vibration gloves must be worn.



- If you notice that the skin of your fingers becomes numb, turns white, tingles or hurts, stop working with the pneumatic tool, inform your employer and seek medical advice.
- Do not make the drill bit jump on the workpiece: this may result in significantly increased vibration.
- Hold the pneumatic tool with a not too firm yet secure grip, compliant with the required hand reaction forces.
- Never carry the pneumatic tool by the hose.

PERSONAL PROTECTIVE EQUIPMENT TO WEAR WHILE OPERATING PNEUMATIC TOOL

 Failure to observe the following warnings may result in physical injury and/or disease.

	ALWAYS WEAR HEARING PROTECTION WHILE OPERATING PNEUMATIC TOOL
	ALWAYS WEAR EYE PROTECTION WHILE OPERATING PNEUMATIC TOOL OR PERFORMING MAINTENANCE JOBS
	ALWAYS WEAR PROTECTIVE GLOVES AGAINST PHYSICAL AGENTS WHILE OPERATING PNEUMATIC TOOL
	ALWAYS WEAR SAFETY SHOES

 **Additional personal protective equipment to wear according to the values found in the environmental hygiene/risk analysis survey if the values exceed the limits under current regulations.**

	WEAR ANTI-VIBRATION GLOVES WHILE OPERATING PNEUMATIC TOOL FOLLOWING A SPECIALLY CONDUCTED SURVEY OF LEVEL OF DAILY EXPOSURE OF HAND-ARM SYSTEM TO VIBRATION
	WEAR PROTECTIVE MASK AGAINST PHYSICAL AGENTS ACCORDING TO THE VALUES FOUND IN THE ENVIRONMENTAL/INDUSTRIAL HYGIENE SURVEY
	WEAR PROTECTIVE HELMET

OPERATION MANUAL AND INSTRUCTIONS

EN

TECHNICAL DATA

CHUCK CAPACITY	1 ÷ 10 mm
SPINDLE THREAD	3/8" 24 UNF
FREE SPEED	1800 rpm
POWER	0,38 kW
AIR INLET	1/4" GAS, cone-shaped
MAXIMUM PRESSURE	6.2 bar
MINIMUM INTERNAL HOSE SIZE (\varnothing)	10 mm
MAXIMUM AIR CONSUMPTION	170 l/min
WEIGHT	1,0 kg
OVERALL LENGTH	182 mm
NOISE (ISO 15744)	
SOUND POWER LEVEL	LWA = 96 dB
SOUND PRESSURE LEVEL	LPA = 85 dB
VIBRATIONS (ISO 28927)	
VIBRATION LEVEL	0.4 m/s ²
UNCERTAINTY	K = 0.53 m/s ²

KEY TO SYMBOLS

- a: Drill trigger
- b: 1/4" GAS air inlet
- c: Chuck reverse lever
- d: Front nut
- e: Rear nut
- f: Chuck opening/closing device
- g: Oil lubrication

Air supply connection

For correct use of the pneumatic tool, always keep to a maximum pressure of 6.2 bar, as measured at the tool inlet.

Feed the pneumatic tool with clean, condensate-free air (**picture 2-b**). Excessively high pressure or humidity in supply air results in shorter life for the mechanical parts and may damage the tool.

USE

Start / Stop

To start the pneumatic tool, press the trigger (**picture 2-a**), and keep it pressed during the job to be performed.

Releasing the trigger will cause the pneumatic tool to stop within 2 seconds.

Check the position of the reverse lever before operating the pneumatic tool, so as to know the direction of rotation.

Setting direction of rotation

The pneumatic tool can rotate both clockwise and anticlockwise. Select the direction of rotation through the reverse lever

(**picture 3c-4c**):

" F " FORWARD  clockwise - seen from the operator's side

" R " REVERSE  anticlockwise - seen from the operator's side

Chuck

The chuck is self-locking. Fit in the drill bit as follows:

- Manually lock the rear nut of the chuck (**picture 5-e**).
- Manually rotate the front nut anticlockwise (**picture 5-d**), and open the chuck until the drill bit fits in.
- Fit in the required drill bit.
- Manually rotate the front nut clockwise, until the chuck is locked.

Replace the drill bit as follows:

- Manually lock the rear nut of the chuck.
- Manually rotate the front nut anticlockwise, to release the drill bit from the chuck.
- Fit in the required drill bit and manually rotate the front nut clockwise, until the chuck is locked.

Always disconnect air supply before fitting in cutting tools or making adjustments; this precaution will prevent the pneumatic tool from being accidentally started.

Lubrication

The pneumatic tool must be connected to a filter-lubricator unit (we recommend Beta item 1919F1/4) provided with an air-oil microfog mixer, set at two drops per minute. This will result in a high-performing tool and wear-resistant mechanical parts.

OPERATION MANUAL AND INSTRUCTIONS

EN

If lubrication is not provided to the line, oil ISO 32 must be periodically poured into the pneumatic tool, through the air supply hole (picture 6-g).

MAINTENANCE

Maintenance and repair jobs must be carried out by trained personnel. For such jobs, you can contact Beta Utensili S.P.A.'s repair centre.

DISPOSAL

The pneumatic tool, accessories and packaging should be sent to a waste disposal centre, in accordance with the laws in force in your country.

WARRANTY

This tool is manufactured and tested in accordance with current EU regulations, and is covered by a 12-month warranty for professional use or a 24-month warranty for nonprofessional use.

We will repair any breakdowns caused by material or manufacturing defects by fixing the defective pieces or replacing them at our discretion.

Should assistance be required once or several times during the warranty period, the expiry date of this warranty will remain unchanged.

This warranty will not cover defects due to wear, misuse or breakdowns caused by blows and/or falls. In addition, this warranty will no longer be valid if any changes are made, or if the pneumatic tool is forced or sent to the customer service in pieces.

This warranty explicitly excludes any damage to people and/or things, whether direct or consequential.

DECLARATION OF CONFORMITY

We hereby declare, assuming full responsibility, that the described product complies with all the relevant provisions of Machine Directive 2006/42/EC and amendments thereto, as well as with the following standard:

- EN ISO 11148-3