

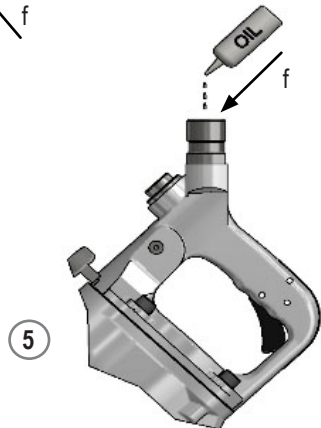

Beta

1930HLA

GB Operation manual and instructions

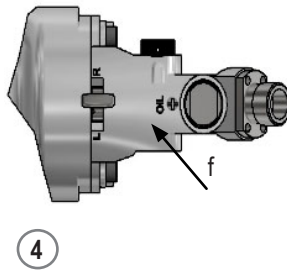
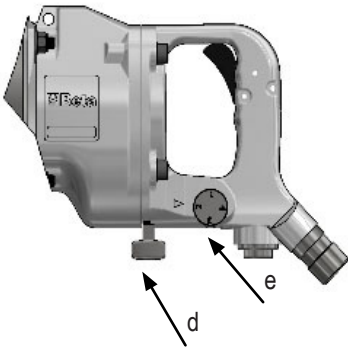
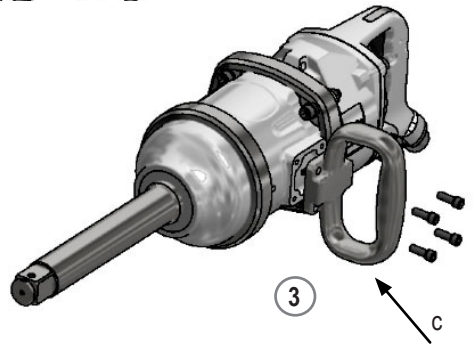
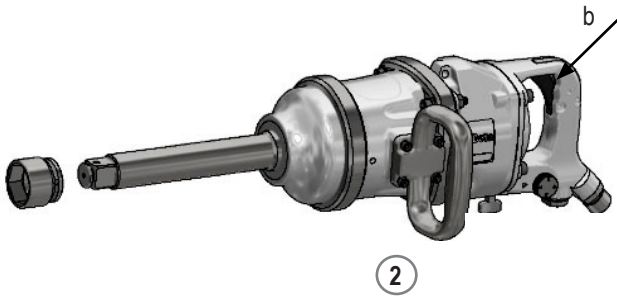
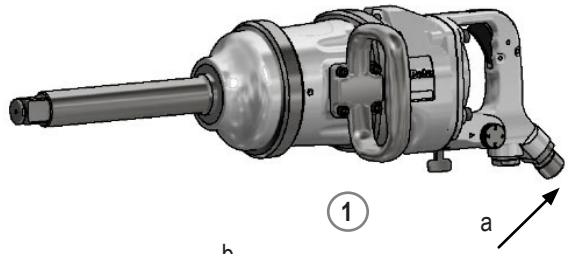

1" REVERSIBLE IMPACT WRENCH ITEM 1930HLA

OPERATION MANUAL AND INSTRUCTIONS FOR REVERSIBLE IMPACT WRENCH MANUFACTURED BY:
BETA UTENSILI S.P.A.

Original documentation drawn up in ITALIAN.



CAUTION



IMPORTANT! READ THIS MANUAL THOROUGHLY BEFORE USING THE PNEUMATIC TOOL. FAILURE TO COMPLY WITH THE SAFETY STANDARDS AND OPERATING INSTRUCTIONS MAY RESULT IN SERIOUS INJURY.

Store the safety instructions with care and hand them over to the users.

PURPOSE OF USE

- **The air impact wrench can be used for the following purposes:**
 - assembling threaded connecting parts
 - screwing and unscrewing by means of impact sockets
 - the impact wrench can also be used in open places exposed to water and air
- **The air impact wrench must not be used for the following operations:**
 - the impact wrench must not be used with any hand sockets
 - the impact wrench must not be used with any couplers or extensions, because these result in reduced power of the impact wrench and increased risk of breakage
 - the impact wrench must not be used in environments containing potentially explosive atmospheres
 - the trigger must not be locked with adhesive tape or clamps

WORK AREA SAFETY

- Beware of both surfaces that may become slippery due to the use of the machine and the danger of tripping over the air hose.
- While using the pneumatic tool for jobs performed high from the ground, take all necessary precautions, to eliminate or minimize risk to other workers, following the accidental falling of any tools (for example, isolation of the work area and proper signs).



Do not operate the pneumatic tool in environments containing potentially explosive atmospheres, because sparks may be generated, which can ignite the dust or fumes.



Avoid contact with live equipment: the pneumatic tool is not insulated, and contact with live parts can cause electric shocks.



Keep children and bystanders away from your workplace while operating the pneumatic tool. Distractions from other people can cause you to lose control over the pneumatic tool.

PNEUMATIC TOOL SAFETY

- Do not point the air flow to yourself or other people. Compressed air can cause serious injury.
- Check the connections and the air supply lines. All units, couplers and hoses should conform to the product specifications in terms of pressure and air volume. Too low pressure impairs the function of the pneumatic tool; too high pressure can cause damage and/or injury.
- Do not bend or tighten any hoses; avoid using solvents and sharp edges. Keep the hoses away from heat, oil and rotating parts. Immediately replace any damaged hose. A defective feed pipe may cause uncontrolled movements of the compressed air pipe. Raised dust or chips may cause eye injury. Make sure that the hose clamps are always secured firmly.

PERSONNEL SAFETY

- Stay alert; watch what you are doing. Do not use the pneumatic tool while tired or under the influence of drugs, alcohol, or medication.
- Always use the following personal protective equipment:
 - eye protection;
 - safety shoes;
 - hearing protection;
 - protective gloves against physical agents;
 - anti-vibration gloves, to be worn following a specially conducted survey of the daily exposure of the hand-arm system to vibration.
- Make sure you are in a safe position, keeping proper balance at all times. A safe working position and a proper body posture enable better control of the pneumatic tool in unexpected situations.
- Do not wear loose clothing or jewellery. Keep your hair, clothing and gloves away from moving parts. Loose clothing, jewellery, and long hair can get caught in moving parts.
- Do not directly inhale the exhaust air, and prevent it from getting into your eyes. The exhaust air of the pneumatic tool can contain water, oil, metal particles and impurities, which may cause hazards.

AIR IMPACT WRENCH USE AND CARE

- Use clamping devices or a vice to secure and support the workpiece. Holding the workpiece by hand or against your body will not allow for safe operation of the pneumatic tool.
- Do not overload the pneumatic tool. Use the pneumatic tool intended for your work only.
- Always check that the machine is free from defects. Do not use a pneumatic tool that has a defective On/Off switch. A pneumatic tool that can no longer be stopped or started is dangerous and must be repaired.
- Make any adjustments while the air impact wrench is not working. Always disconnect the air supply when not in use. This safety measure prevents accidental starting of the pneumatic tool.
- Store idle pneumatic tools out of the reach of children. Do not allow persons unfamiliar with these instructions to operate the pneumatic tool.
- Maintain the pneumatic tool with care. Check for misalignment or binding of moving parts, breakage or damage of parts and any other condition that may affect the operation of the pneumatic tool. Have damaged parts repaired before using the pneumatic tool.
- Always use impact sockets in good condition.
- Do not modify the pneumatic tool. This can reduce the effectiveness of safety measures and increase operator risk.
- Have the pneumatic tool repaired only through a trained repair person and only using original replacement parts.

AIR IMPACT WRENCH SAFETY

- Make sure that the nameplate is readable; get a replacement nameplate from the manufacturer, if need be.
- While the impact wrench is being used, any accidental breakages of individual accessories may cause pieces to be thrown at high speed.
- Operators and maintenance personnel should be physically able to handle the weight and power of the pneumatic tool.
- It is important to be prepared for unexpected movements of the air impact wrench resulting from a jammed or broken work tool. Maintain a firm grip on the pneumatic tool and position your body and arms to allow you to resist such movements. These precautions can prevent injuries.
- Avoid contact with any moving parts of the tool, since these can cause injuries.
- Make sure that the direction of rotation of the air impact wrench is fit for use.
- Turn off the tool in case of air supply failure or low operating pressure. Check the operating pressure; turn on the tool again when optimal operating pressure is resumed.
- When using the pneumatic tool, the operator can experience discomfort in the hands, arms, shoulders, or neck area. Adopt a comfortable position and avoid awkward postures. Changing one's posture may help avoid discomfort and fatigue.



Caution: If the pneumatic tool is used over a protracted period of time, part of the tool and the socket may become hot. Wear protective gloves.



Using the pneumatic tool on the workpiece generates noise, which may prove harmful to the exposed personnel. A proper phonometric survey is required to determine the personal hearing protective equipment (hearing protection) to use.



If a specially conducted survey suggests that the daily exposure to vibration generated from the pneumatic tool exceeds the limit value under the regulations in force in the respective country, anti-vibration gloves must be worn.





- If you notice that the skin of your fingers becomes numb, turns white, tingles or hurts, stop working with the pneumatic tool, inform your employer and seek medical advice.
- Hold the pneumatic tool with a not too firm yet secure grip, compliant with the required hand reaction forces.
- Never carry the pneumatic tool by the hose.

OPERATION MANUAL AND INSTRUCTIONS

GB

PERSONAL PROTECTIVE EQUIPMENT TO WEAR WHILE OPERATING PNEUMATIC TOOL

! Failure to observe the following warnings may result in physical injury and/or disease.

	ALWAYS WEAR HEARING PROTECTION WHILE OPERATING PNEUMATIC TOOL
	ALWAYS WEAR EYE PROTECTION WHILE OPERATING PNEUMATIC TOOL OR PERFORMING MAINTENANCE JOBS
	ALWAYS WEAR PROTECTIVE GLOVES AGAINST PHYSICAL AGENTS WHILE OPERATING PNEUMATIC TOOL
	ALWAYS WEAR SAFETY SHOES

! Additional personal protective equipment to wear according to the values found in the environmental hygiene/risk analysis survey if the values exceed the limits under current regulations.

	WEAR ANTI-VIBRATION GLOVES WHILE OPERATING PNEUMATIC TOOL FOLLOWING A SPECIALLY CONDUCTED SURVEY OF LEVEL OF DAILY EXPOSURE OF HAND-ARM SYSTEM TO VIBRATION
----------------------------------------------------------------------------------	-------------------------------------------------------------------------------------------------------------------------------------------------------------

TECHNICAL DATA

SOCKET DRIVE ANVIL BOLT CAPACITY (8.8) BOLT CAPACITY (12.9) FREE SPEED MAXIMUM TORQUE AIR INLET MAXIMUM PRESSURE MINIMUM INTERNAL HOSE SIZE (ø) MAXIMUM AIR CONSUMPTION WEIGHT LENGTH HAMMER DEVICE TYPE NOISE (ISO 15744) - SOUND POWER LEVEL - SOUND PRESSURE LEVEL VIBRATIONS (ISO 28927) - VIBRATION LEVEL Uncertainty	1" 8" M42 - 65 mm M33 - 50 mm 3000 rpm 3661 Nm 1/2" GAS 6.2 bars 13 mm 460 l/min 16.4 kg 628 mm DOUBLE HAMMER LwA = 113.4 dB LpA = 102.4 dB 69.6 m/s ² K=23 m/s ²
----------------------------------------------------------------------------------------------------------------------------------------------------------------------------------------------------------------------------------------------------------------------------------------------------------------------------------------------------------------------------------	-------------------------------------------------------------------------------------------------------------------------------------------------------------------------------------------------------------------------------------------------

KEY TO SYMBOLS

- a: air inlet 1/2" GAS
- b: impact wrench trigger
- c: side handle
- d: rotation reversal lever
- e: power adjustment
- f: oil lubrication

INSTRUCTIONS FOR INSTALLING DEVICES

Side handle installation

Assemble the auxiliary handle (picture 3-c) by screwing it onto the front body of the air impact wrench (manually tighten the four screws supplied with the impact wrench by means of the hexagon driver). The auxiliary handle can only be mounted on the left side of the impact wrench body. Using the auxiliary handle results in increased ease of handling and firmness.

Air supply connection

For correct use of the pneumatic tool, always keep to a maximum pressure of 6.2 bars, as measured at the tool inlet. Feed the pneumatic tool with clean, condensate-free air (picture 1-a). Excessively high pressure or humidity in supply air results in shorter life for the mechanical parts and may damage the tool.

USE

Start / Stop

To start the air impact wrench, press the start lever (picture 2-b), and keep it pressed during the job to be performed. Releasing the trigger will cause the pneumatic tool to stop quickly.

Check the position of the reverse lever before operating the pneumatic tool, so as to know the direction of rotation.

Setting direction of rotation

The pneumatic tool can rotate both clockwise and anticlockwise. Select the direction of rotation through the reverse lever (picture 4-d) in the lower part of the handle. Four different power levels can be selected, through selection 1-2-3-4 (picture 4-e).

“ L ” LEFT  clockwise – seen from the operator's side

“ R ” RIGHT  anticlockwise – seen from the operator's side

Fit the required impact socket onto the male drive, and make sure that it is inserted correctly.

Always disconnect the air supply before fitting in tools or making adjustments; this precaution will prevent the pneumatic tool from being accidentally started.

Lubrication/Greasing

The pneumatic tool must be connected to a filter-lubricator unit provided with an air-oil microfog mixer (we recommend Beta item 1919F1/2), set at two drops per minute. This will result in a high-performing tool and wear-resistant mechanical parts.

If lubrication is not provided to the line, oil ISO 32 must be periodically poured into the pneumatic tool, through either the air supply hole or the screw (pictures 4-f, 5-f).

MAINTENANCE

Maintenance and repair jobs must be carried out by trained personnel. For such jobs, you can contact Beta Utensili S.P.A.'s repair centre.

DISPOSAL

The pneumatic tool, accessories and packaging should be sent to a waste disposal centre, in accordance with the laws in force in your country.



WARRANTY

This tool is manufactured and tested in accordance with current EU regulations, and is covered by a 12-month warranty for professional use or a 24-month warranty for nonprofessional use.

We will repair any breakdowns caused by material or manufacturing defects by fixing the defective pieces or replacing them at our discretion.

Should assistance be required once or several times during the warranty period, the expiry date of this warranty will remain unchanged.

This warranty will not cover defects due to wear, misuse or breakdowns caused by blows and/or falls. In addition, this warranty will no longer be valid if any changes are made, or if the pneumatic tool is forced or sent to the customer service in pieces.

This warranty explicitly excludes any damage to people and/or things, whether direct or consequential.

DECLARATION OF CONFORMITY CE

We hereby declare, assuming full responsibility, that the described product complies with all the relevant provisions of Machine Directive 2006/42/EC and amendments thereto, as well as with the following standard:

- EN ISO 11148-6