

C55AC
055000360

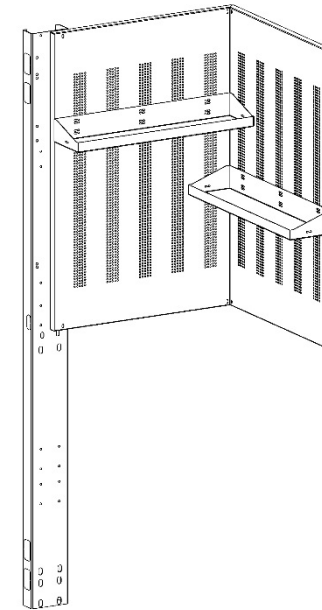

C55KAS
Upper corner

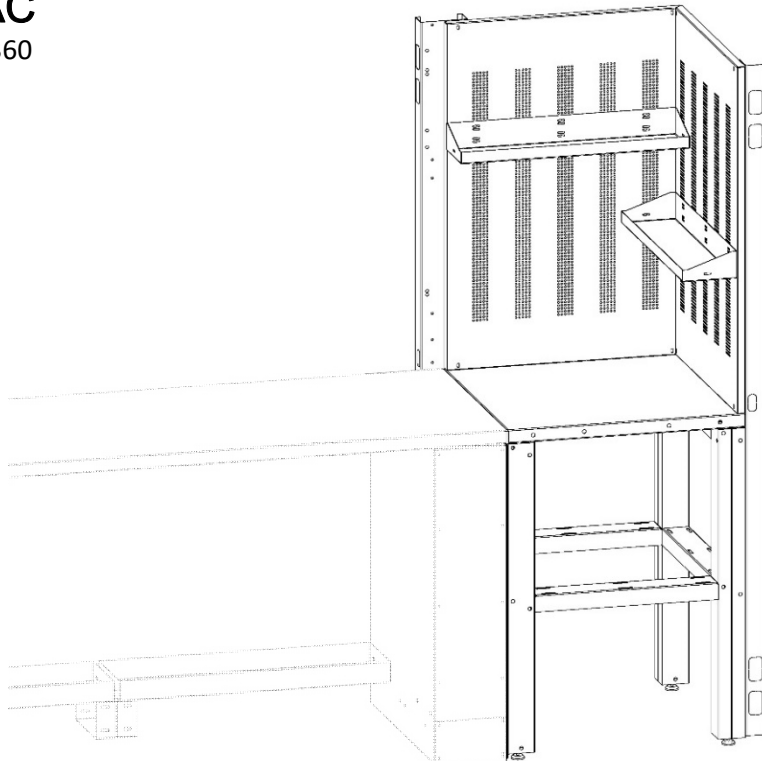

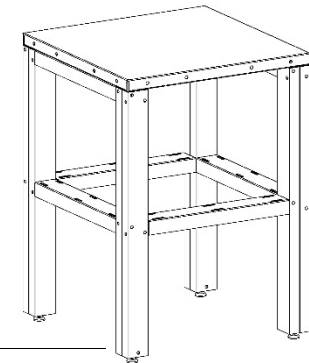

055000370

C55KAI
Corner worktop

055000365

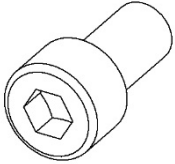
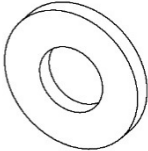
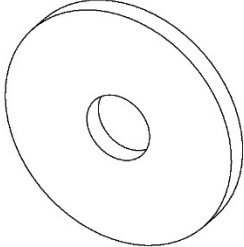
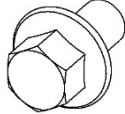

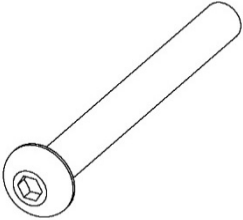
Code	Description	Pcs.
055000371	700x700mm Worktop	1
055000372	Plain leg	2
055000373	Perforated tool panels upper corner	2
055000374	Shelves for tool panels	2
055000257	Intermediate vertical support	1

A 	B 	C 	D 
M8 x 16 screw	washer D.8	washer wide band D.8	M6 x 10 screw
E 	F 	G 	H 
M6 nut	M5 x 45 screw	self-tapping screw	expansion plug

Commercial parts that you can find in the compositions, to fix the elements.

Plain leg

055000372

4x A+B

4x A+B

4x A+B

4x A+B

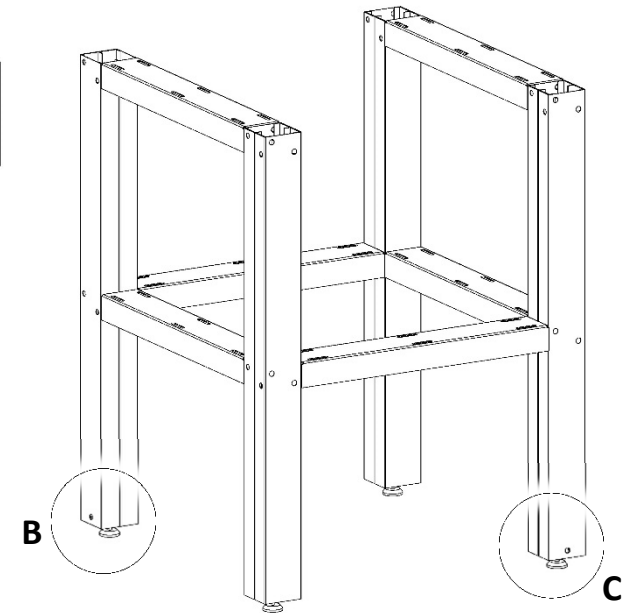
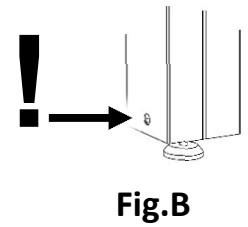
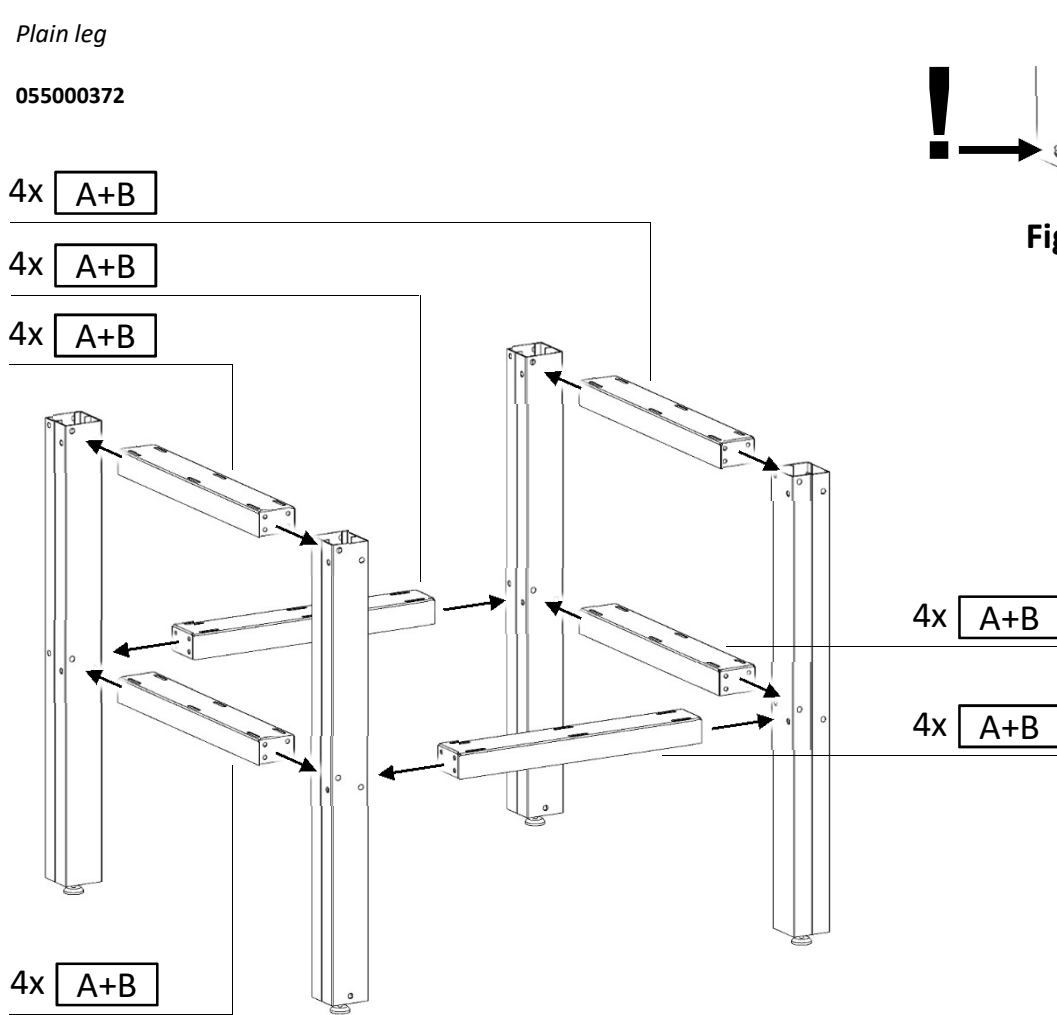

4x A+B

4x A+B

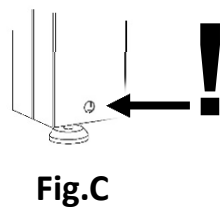

Attention! Keep the holes fig. B and C aligned with the vertical supports.

700x700mm Worktop

055000371

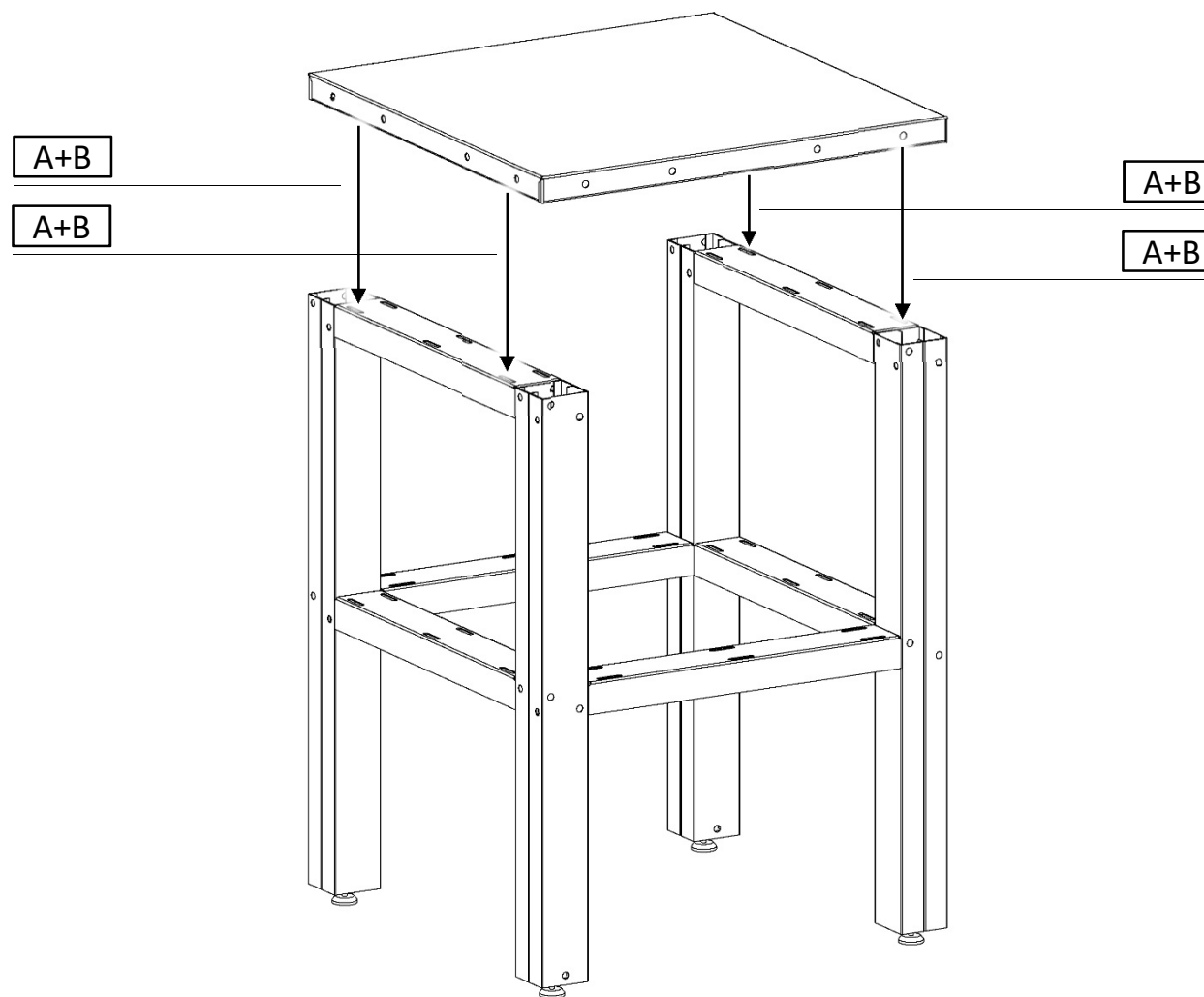

Intermediate vertical support

055000257

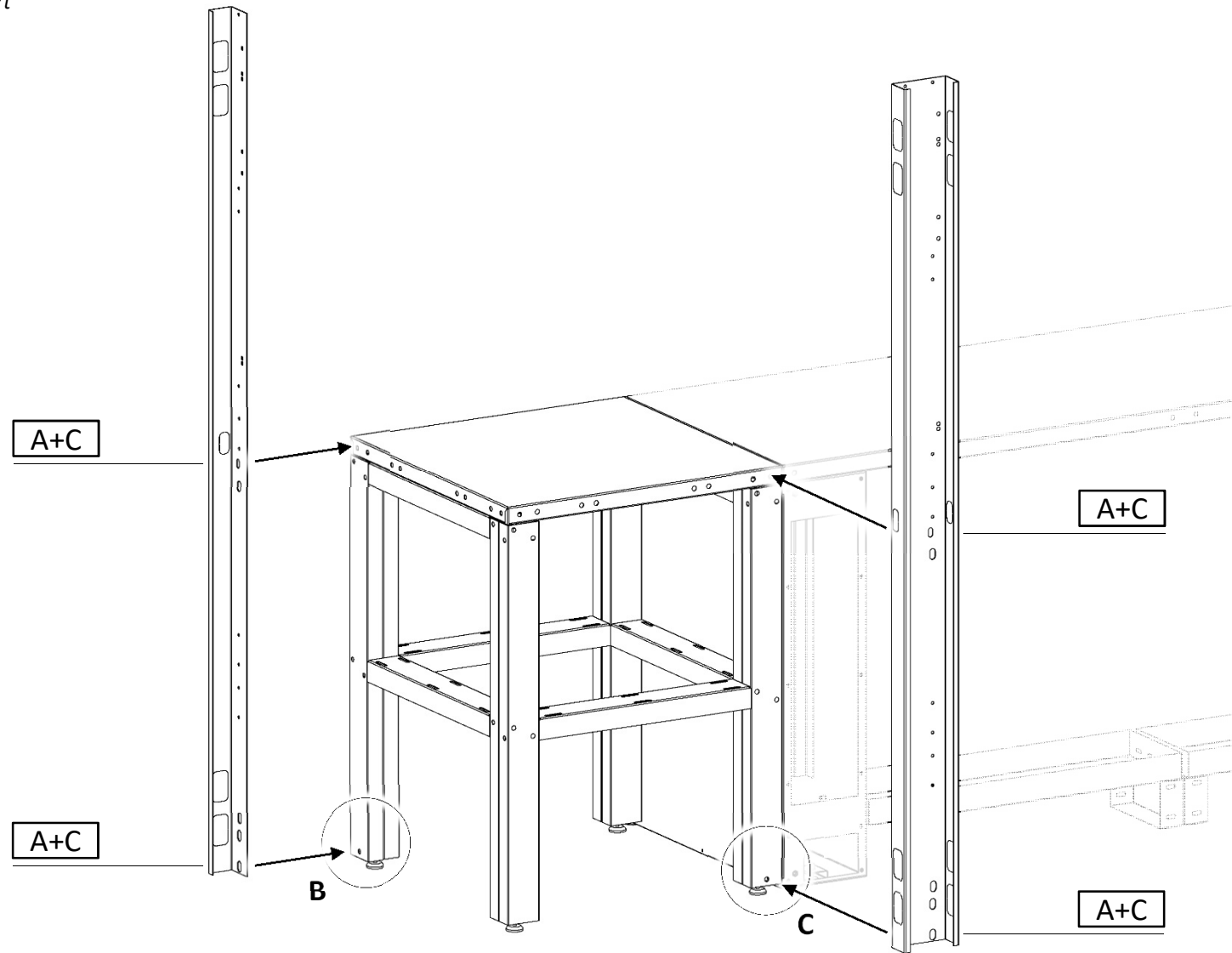

Perforated tool panels upper corner

055000373

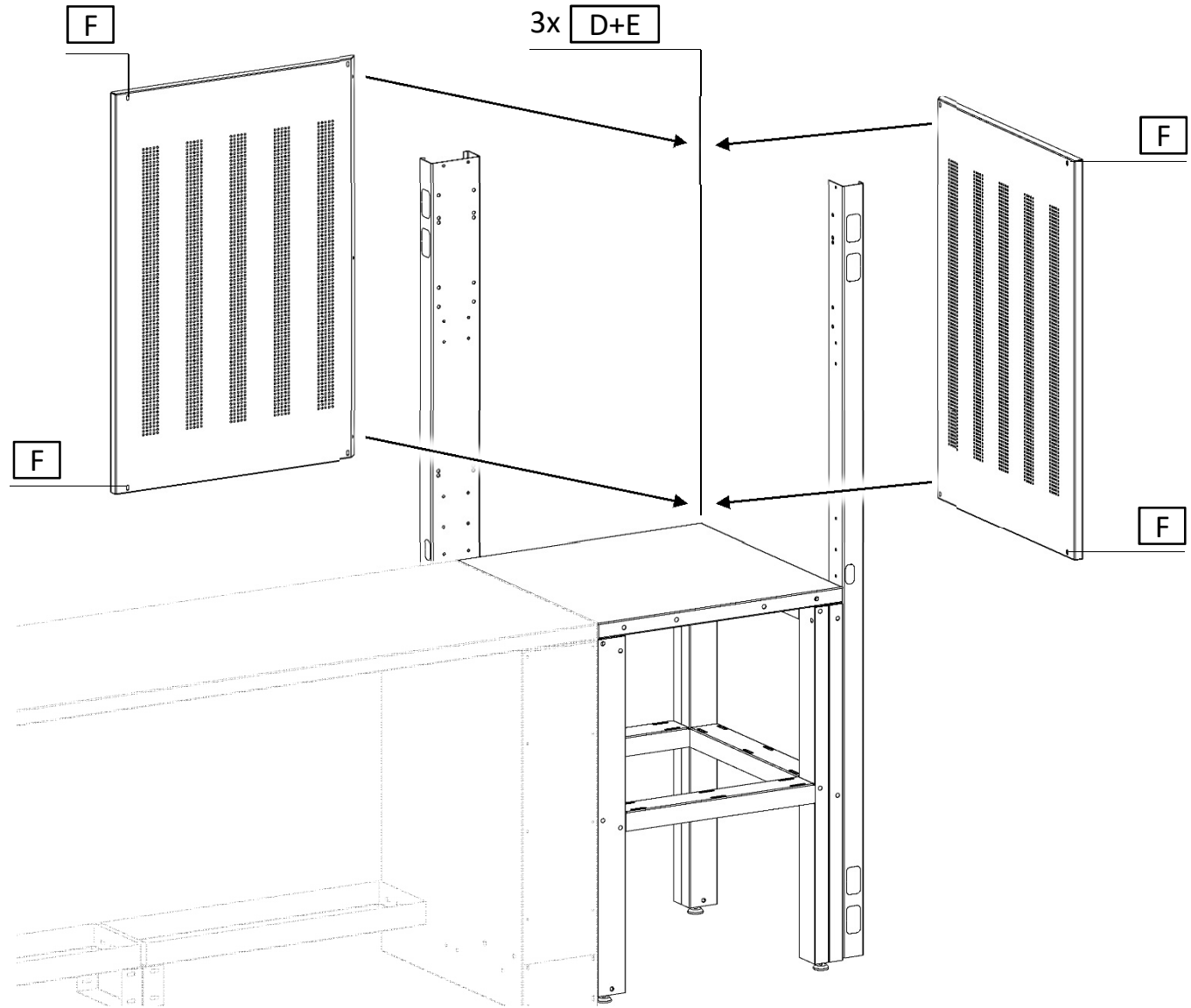

Shelves for tool panels

055000374

