

*BelAir*  
COMPRESSORS

# Air Compressor Manual

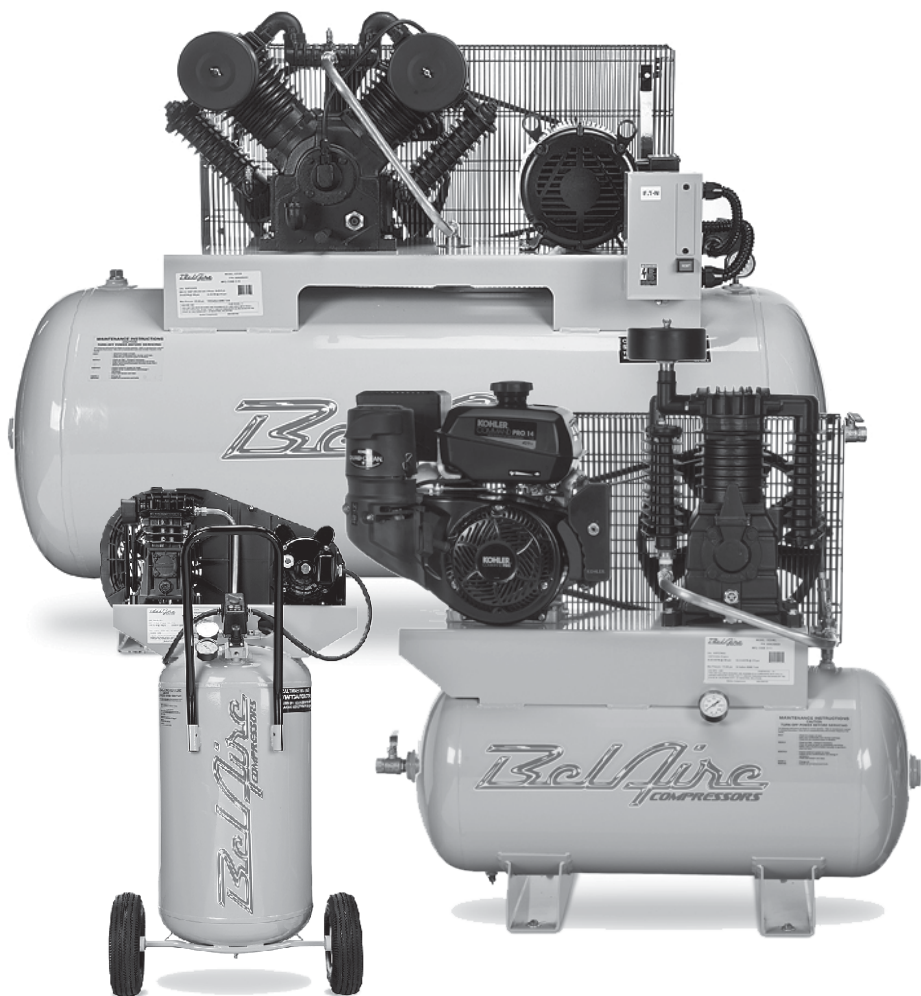

# TABLE OF CONTENTS

## PAGE

1	Safety Guidelines - Definitions Before Using the Air Compressor
2	When Installing or Moving the Compressor Before Each Use
3	Follow Safety Precautions for Electrical Connection Plan Ahead to Protect Your Eyes, Hands, Face & Ears When Operating
4	Spraying Precautions Perform These Maintenance Operations
5	Typical Compressor Installation Glossary
6-9	Wiring
10-11	Starting the Compressor
12	QP Compressor
13-14	Troubleshooting
15	Pump and Tank Specs
16	Tank Warning
17	Parts Reference
18	Single Stage and Contractor
19	Two Stage
20	Gas Drive and Duplex
21	QP
22	Electric Two Stage and Duplex
23-24	B2800 and B3800
25	T29S
26	B5900
27	T39
28-29	C1
30-31	C2

# SAFETY GUIDELINES - DEFINITIONS

Safety is a combination of common sense, staying alert and knowing how your compressor works. Read this manual to understand this compressor.



## DANGER

means if safety information is not followed someone **will** be seriously injured or killed



## WARNING

means if safety information is not followed someone **could** be seriously injured or killed



## CAUTION

means if safety information is not followed someone **may** be seriously injured or killed

# IMPORTANT SAFETY INSTRUCTIONS

## *Save these instructions*

Improper operation or maintenance of this product could result in serious injury and property damage. Read and understand all warnings and operation instructions before using this compressor.

## *Before using the air compressor*

### Things you should know

Air compressors are utilized in a variety of air system applications. Because air compressors and other components (hoses, connectors, air tools, spray guns, etc.) make up a high pressure pumping system, the following safety precautions should be observed at all times.

### Only persons familiar with these rules of safe operation should use the air compressor.

1. Read the instruction manual carefully before attempting to assemble, disassemble or operate your system. Be thoroughly familiar with the controls and the proper use of the equipment.
2. Review and understand all safety instructions and operating procedures in this manual.
3. Review the maintenance methods for this compressor (See "Maintaining Your Compressor" section).

### Inspect your work area

1. Keep work area clean.
2. Cluttered areas and benches invite accidents. Floors must not be slippery from wax or dust.

### Inspect your compressor

1. To reduce the risk of injury from accidental starting, turn switch off and disconnect the power before checking it.
2. If any part is missing, bent or broken in any way, or any electrical part does not work properly, keep the compressor off and disconnected.
3. Check hoses for weak or worn condition before each use, making certain all connections are secure. Do Not use if defect is found.



## WARNING

Do not operate compressor if damaged during shipping, handling or use. Damage may result in bursting and cause injury or property damage.



## DANGER

This compressor is Not designed for and should not be used in breathing air applications.

## When installing or moving the compressor

### **WARNING**

This compressor is extremely top heavy. The compressor must be bolted to the floor with vibration pads before operating to prevent equipment damage, injury or death. **Do Not** tighten bolts completely as this may cause stress to the tank welds. **Chart 1a**.

#### To reduce the risk of a dangerous environment

1. Keep work area well lit.
2. Operate compressor in a well-ventilated area free from flammable liquids and vapors.
3. Operate compressor in a ventilated area so that compressor may be properly cooled and the surrounding air temperature will not be more than 100°F.
4. Never use a compressor in a wet environment.
5. Protect material lines and air lines from damage or puncture. Keep hose and wires away from sharp objects, chemical spills, oil, solvents and wet floors.

### **WARNING**

**Do Not** secure compressor with toggle bolts into drywall. Drywall sheeting or plaster will not support the weight of the compressor.

Always Shut Off Gas Valve before moving Gas Drive Compressors

6. A minimum clearance of 18 inches between the compressor and a wall is required because objects could obstruct airflow.
7. The compressor should be located where it can be directly wired to a circuit breaker. The compressor should be wired by a qualified electrician.
8. Never store flammable liquids or gases in the vicinity of an operating compressor.
9. **Do Not** locate the compressor air inlet near steam, paint spray, sandblasting areas or any other source of contamination. The debris could damage the motor and pump.

### **WARNING**

Never use plastic (PVC) pipe for compressed air. Serious injury or death could result.

### **CAUTION**

Never use the shipping skid for mounting the compressor.

### **NOTICE**

Electric Compressors are not suitable for outdoor installation.

### **NOTICE**

Gasoline Compressors must be operated outdoors, sheltered from the weather.

### **WARNING**

Never install a shut off valve between the compressor pump and tank. Personal injury and/or equipment damage could occur.

## Before each use

### Inspect your work area

1. Keep work area clean. Cluttered areas and benches invite accidents.
2. The floor must not be slippery from wax or dust.

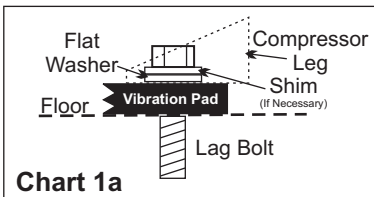

Chart 1a

### Inspect your compressor

1. To reduce the risk of injury from accidental starting, turn the switch off and disconnect power.
2. If any part is missing, bent or broken in any way, or any electrical part does not work properly, keep the compressor off and disconnect power. **Do Not** use if defect is found.
3. Check hoses for weak or worn condition before each use, making certain all connections are secure. **Do Not** use if a defect is found.

## ***Follow the safety precautions for electrical connections***

1. Follow all local electrical and safety codes, as well as the National Electric Code (NEC) and the Occupational Safety and Health Act (OSHA).
2. Wiring and fuses should follow electrical codes, current capacity and be properly grounded.
3. Protect wires from contact with sharp objects.



### **CAUTION**

All electrical connections should be made by a qualified electrician.

## ***Plan ahead to protect your eyes, hands, face and ears***

### **Dress for safety**

1. Wear safety glasses (meeting ANSI Z87.1 or in Canada CSA Z94.3-99) and use hearing protection when operating the unit. Everyday glasses are not safety glasses.
2. Wear shoes to prevent shock hazards.
3. Tie back long hair.



### **WARNING**

Be careful when touching the exterior of compressor, pump, motor and air lines; they may become hot enough to cause injury.



### **WARNING**

Never operate the compressor without a beltguard. The compressor can start automatically without warning. Personal injury or property damage could occur from contact with moving parts.



### **CAUTION**

The compressor may be hot even if the unit is stopped.



### **WARNING**

Use of a mask or respirator per chemical manufacturers' instructions may be necessary if there is a chance of inhaling toxic fumes. Read mask and respirator instructions carefully. Consult a safety expert if you are not sure about the use of certain masks or respirators.

### **Pay attention to your hands**



### **WARNING**

Keep fingers away from running compressor. Fast moving and hot parts may cause injury and/or burns.

## ***When operating***

1. Do not exceed the pressure rating of any component of the system.
2. Release pressure within the system slowly to prevent flying dust and debris.
3. If the equipment starts to abnormally vibrate, STOP the compressor immediately and check for the cause.



### **WARNING**

Never change the safety valve or pressure switch settings. Keep safety valve free from paint and other accumulations. See compressor specification decal for maximum operating pressure. Do not operate with the pressure switch set higher than the maximum operating pressure.

## Spraying precautions



### WARNING

Never point a spray gun at yourself or any other person or animal. Accidental discharge may result in serious injury.

#### Reduce the risk of dangerous environment



### WARNING

Extreme caution should be taken when spraying flammable liquids as the spark from a motor or pressure switch may cause a fire or explosion. Ample ventilation must be provided.



### WARNING

Spray in a well ventilated area to keep fumes from collecting and causing serious injury and fire hazards.

1. **Do Not** spray in the vicinity of open flames or other places where a spark can cause ignition. **Do Not** smoke when spraying paint, insecticides, or other flammable substances.

#### Be informed about the materials you use

1. When spraying with solvents or toxic chemicals, follow the instructions provided by the chemical manufacturer. Consult a safety expert if unsure about the use of masks or respirators.
2. If the material you intend to spray contains trichloroethane and methylene chloride, do not use accessories that contain aluminum or galvanized materials, as these chemicals can react with galvanized components causing corrosion and weakening equipment. Use stainless steel accessories.

## Perform these maintenance operations

1. Do regular maintenance; keep all nuts, bolts, and screws tight, to be sure equipment is in safe working condition.
2. Inspect tank yearly for rust, pin holes or any other imperfections that could cause it to become unsafe.
3. Clean electrical equipment with an approved cleaning agent, such as a dry, non-flammable cleaning solvent.
4. Drain tanks of moisture after each day's use. If unit will not be used for awhile, it is best to leave the drain cock open until such time as it is to be used. This will allow moisture to completely drain out and help prevent corrosion of inside of tank.
5. Always disconnect from power source before working on or near a motor, or its connected load. If power disconnect point is out-of-sight, secure it in the "OFF" position and tag it to prevent unexpected application of power.



### WARNING

NEVER attempt to repair or modify a tank! Welding, drilling or any other modification will weaken the tank resulting in damage from rupture or explosion. Always replace worn, cracked or damaged tanks.

3. Clean electrical equipment with an approved cleaning agent, such as a dry, non-flammable cleaning solvent.



### WARNING

Disconnect power and depressurize system before servicing air compressor. Slightly open drain cock after shutting off compressor.

#### Daily

Check oil level at sight glass. Oil level should be 1/2 to slightly higher in the oil sight glass.

Drain moisture from tank.

Verify the pressure switch unloader is working by listening for a brief hissing sound when the compressor shuts off.

Visually check the compressor for loose parts, excessive noise or vibration. Tighten any necessary part.

#### Monthly

(Make sure the main power is off.) Check the belts for tension. Belts should not move up and down when the compressor runs and when stopped, should not have more than 1/2 in of play when depressed. Be careful not to over tighten belts during adjustment.

Remove and check air filter, replace if necessary.

Change oil every 3 months or 300 hours. A compressor grade 30 wt non-detergent oil should be used. *40 wt non-detergent for single stage.*

# TYPICAL COMPRESSOR INSTALLATION

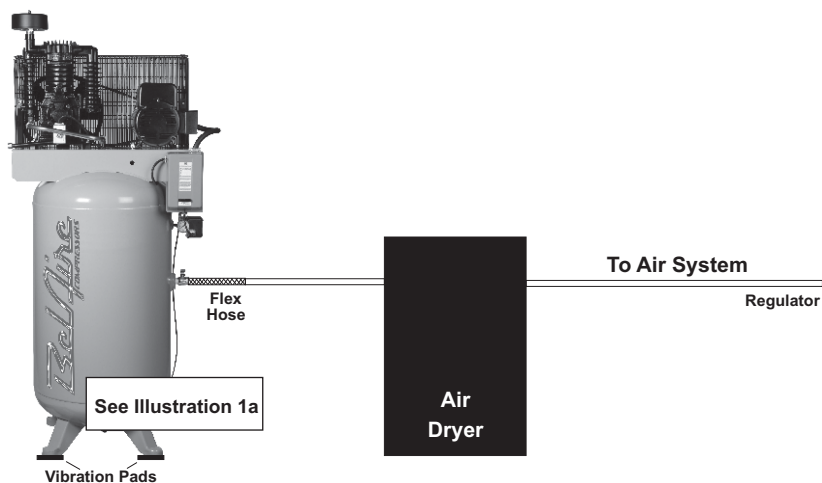

## GLOSSARY OF TERMS

### Air Filter

Porous element contained within a metal or plastic housing attached to the compressor cylinder head which removes impurity from the intake air of the compressor.

### Air Tank

Cylindrical component which contains the compressed air.

### Check Valve

Device which prevents compressed air from flowing back from the air tank to the compressor pump.

### Electric Motor

Device which provides the rotational force necessary to operate the compressor pump.

### Pressure Gauge

Device which shows the tank or regulated pressure of the compressed air.

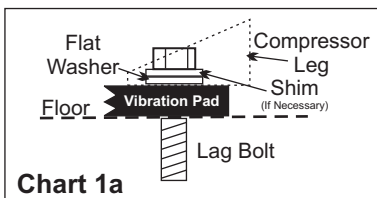

Chart 1a

### Pressure Switch

Device which automatically controls the on/off cycling of the compressor. It stops the compressor when the cut-off pressure in the tank is reached and starts the compressor when the air pressure drops below the cut-in pressure.

### PSI (Pounds per Square Inch)

Measurement of the pressure exerted by the force of air. The actual psi is measured by a pressure gauge on the compressor.

### Pump

Device which produces the compressed air with a reciprocating piston contained within a cylinder.

### Safety Valve

Device which prevents air pressure in the air tank from rising over a predetermined limit.

### Thermal Overload Switch

Device, integrated into the electric motor winding, which automatically "shuts off" the compressor if the temperature of the electric motor exceeds a predetermined limit.



# WIRING

## WARNING

ALL ELECTRICAL WIRING SHOULD BE DONE BY A QUALIFIED ELECTRICIAN

### General Information

Adequate wiring and motor protection should be provided for all stationary compressors. Wiring used for other machinery should not be used. A qualified electrician familiar with local electrical codes in your area should be used. Size supply wiring per NEC (National Electric Code) requirements.

## WARNING

To reduce the risk of electrical hazards, fire hazards or damage to the compressor, use proper circuit protection. Your compressor is wired at the factory for operation using the voltage shown. Connect the compressor to a power source with the correct breaker size.

## WARNING

Electrical connections must be properly grounded. Ground connections should be connected at the grounding screw.

## CAUTION

Overheating, short circuiting and fire damage will result from inadequate wiring.

Incoming power should be connected to L1 and L2 at the Top of the Magnetic Starter.

### Overload Adjustment

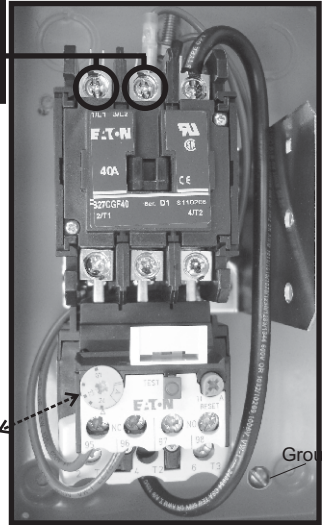
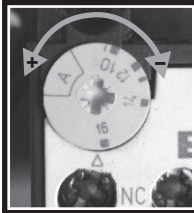

Single Phase

**DO NOT MAKE CONNECTIONS AT THE PRESSURE SWITCH (Units with Magnetic Starters)**

## DUPLEX

Power should be brought into the left hand starter. Do not bring power to both starters.

Incoming power should be connected to L1, L2 & L3 at the Top of the Magnetic Starter.

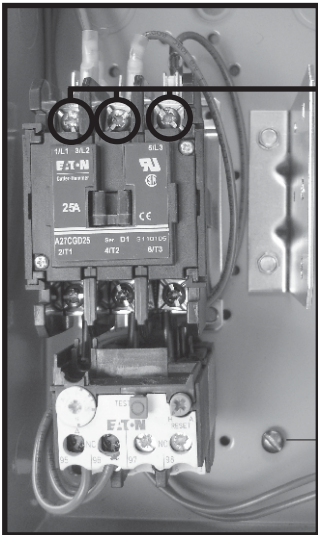

Three Phase

## For Models Without Magnetic Starter

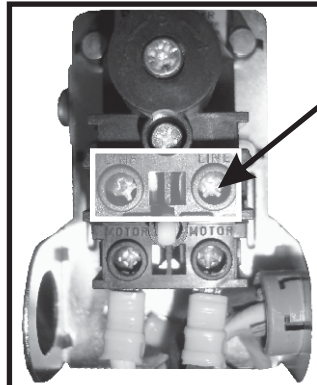

Incoming power should be connected to the posts marked (LINE)



**Do Not Make Connections On Prewired Posts Marked (MOTOR)!**



Electrical connections must be properly grounded. Ground connections should be connected at a grounding screw. 



# WIRING

## 1 PHASE START/STOP CONTROL WIRING SCHEMATIC

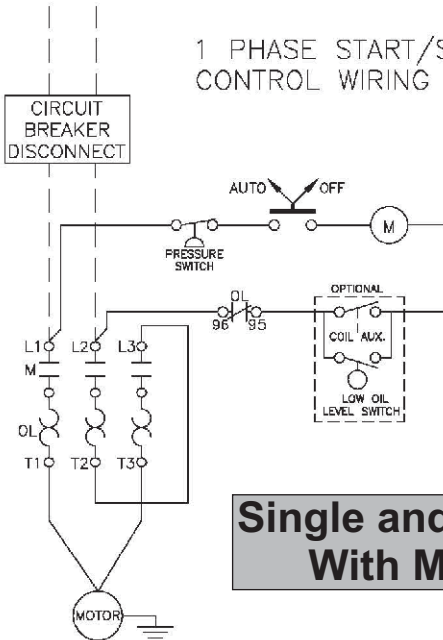

## Single and Three Phase With Mag Starter

## 3 PHASE START/STOP CONTROL WIRING SCHEMATIC

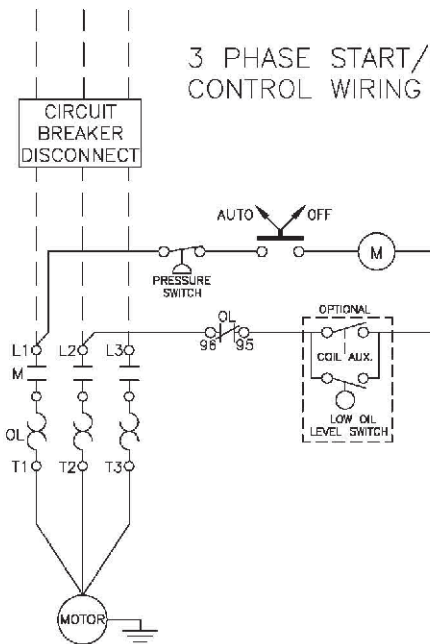

--- Customer supplied

# WIRING

## DUPLEX 1 PHASE START/STOP CONTROL WIRING SCHEMATIC

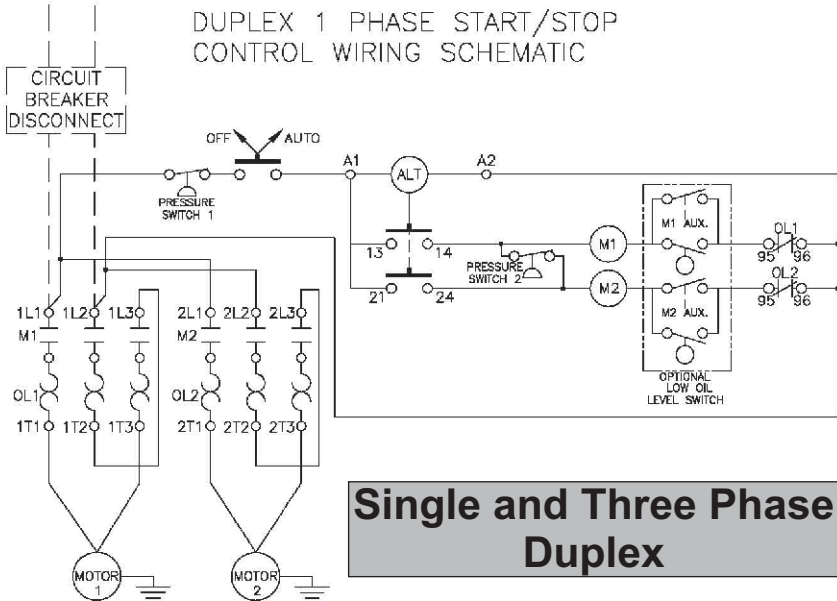

## Single and Three Phase Duplex

## DUPLEX 3 PHASE START/STOP CONTROL WIRING SCHEMATIC

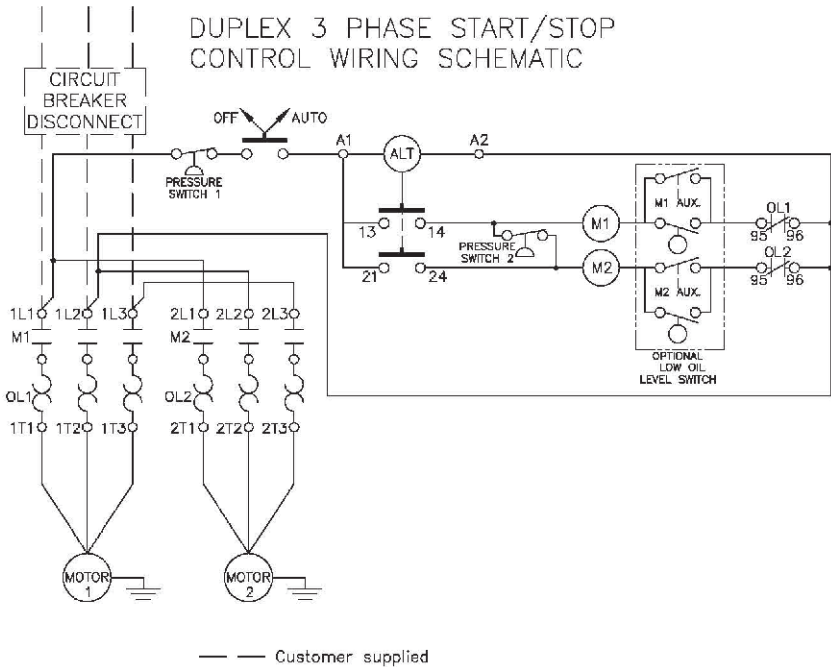

# WIRING

## QP 1 PHASE START/STOP CONTROL WIRING SCHEMATIC

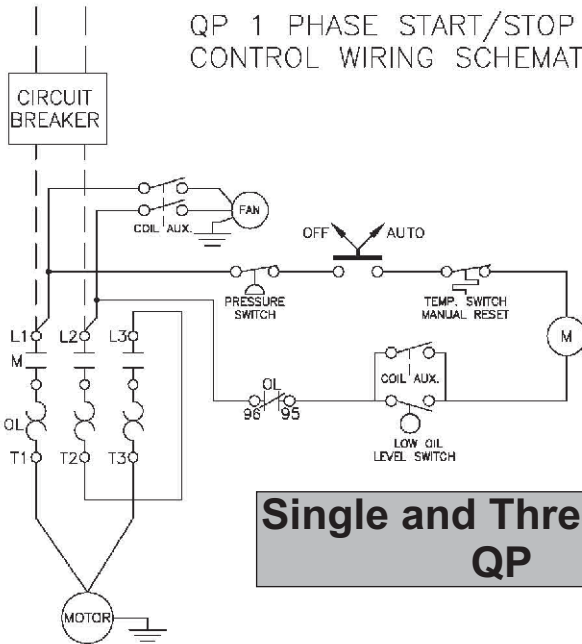

## QP 3 PHASE START/STOP CONTROL WIRING SCHEMATIC

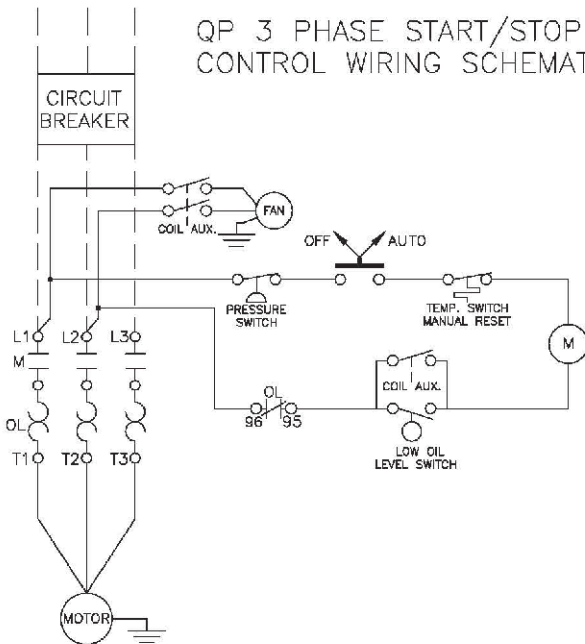

— — Customer supplied

# STARTING THE COMPRESSOR

Prior to actually running the compressor, check the following items:

Crankcase oil - Make sure the sight glass shows  $\frac{1}{2}$  full or slightly above.

Make sure all rags, tools, oil, etc. are away from the unit.

Open the air system to free it of any pressure.

Switch the compressor on for a few revolutions to make sure the rotation is correct. Correct rotation is clockwise when facing the sight glass on the pump.

Operate the compressor for a few minutes unloaded (air system open) then allow the compressor to pump up. Make sure the electrical pressure switch properly switches off the compressor according to the setting desired. 175 for Two Stage. (135 psi - Single Stage or 165 psi - RCP-561VNS)



## CAUTION

Make sure the pressure in the tank does not exceed its rating. Single Stage units - 135 psi Two Stage units at a maximum of 175 psi. (165 for Model RCP-561VNS)  
If the pressure gauge indicates a pressure that is higher than these maximum pressures, shut off compressor immediately and call your distributor.

### *(Gas Drive Models)*

**PLEASE REFER TO YOUR ENGINE OPERATION MANUAL FOR PROPER STARTING INSTRUCTIONS.**

**GASOLINE DRIVEN COMPRESSORS ARE EQUIPPED WITH A COLD START VALVE FOR LOADLESS STARTS.**

**NOTE: IN SOME INSTANCES, IT STILL MAY BE NECESSARY LIFT THE TOGGLE ON THE UNLOADER/PILOT VALVE TO RELIEVE THE HEAD PRESSURE. See Page 11**

### ***Battery Connection Instructions for Electric Start Engines***

Note: Make sure to follow instructions carefully to avoid a short and possible damage to the starter solenoid and/or battery.

1. Connect the positive (+) terminal on the battery to the starter solenoid.
2. Connect the negative (-) terminal on the battery to an engine mounting bolt or other acceptable ground connection.

Always connect the positive(+) battery cable to the starter solenoid before connecting the negative(-) battery cable.

### **NUMBER 2 WIRE OR LARGER IS REQUIRED**

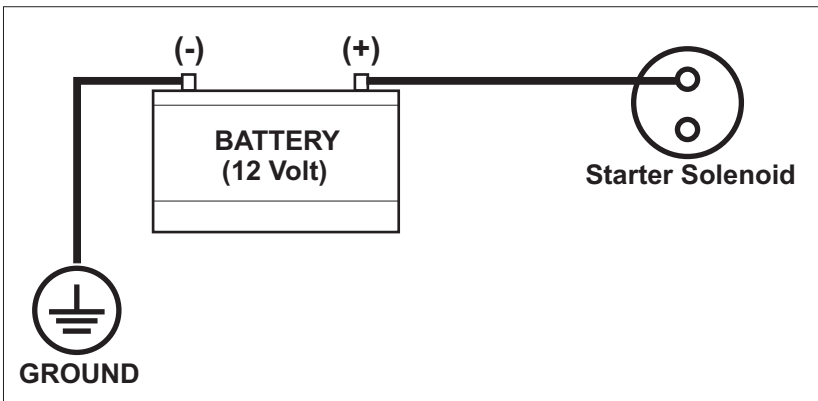

# Cold Start Procedure (Gasoline Engine Units)

## Warning: Do Not Operate Gasoline Engine Units in an Enclosed Area

- Release any remaining tank pressure by slowly opening the manual drain valve.
- Turn on the engine gasoline supply.
- Put the choke in the “On” position
- Close the service valve and put Unloader lever in the “unload” (A) position for Briggs and Stratton and Honda engine driven models, or the “load” (B) position for Kohler engine models.
- Start the engine, release the choke, and allow the engine to warm up for two to three minutes.
- Return the unloader lever to the “load” (B) position on Briggs and Stratton and Honda driven models.

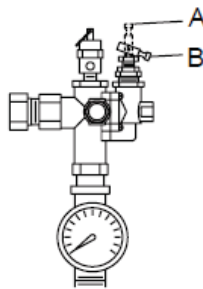

**Note: Turn the gasoline supply off when the compressor is not being used**

## QP Compressors

You have purchased a state of the art BelAire QP compressor. The QP comes equipped with sound attenuating enclosure. For maintenance, the canopy and side foam pieces will need to be removed.

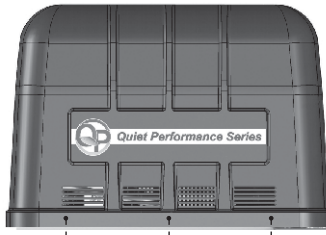

To remove the canopy, simply remove the 6 fasteners and lift the canopy straight up and off.

## QP and Elite Compressors

BelAire *ELITE* and QP models come equipped with low oil level switches and automatic tank drains. The QP models also include protection against over-heating.

## Low Oil Level Switch

The function of the low oil level switch is to keep the air compressor from starting if the oil level drops beyond a certain point.

For compressors outfitted with the low oil level switch, the oil should be in the top 1/3 of the oil sight glass.

When changing or adding oil, it is important to remove the Oil Vent Plug to allow for the oil to flow completely into the switch.

(Please Note: If overfilled, oil will flow out of the oil vent hole)

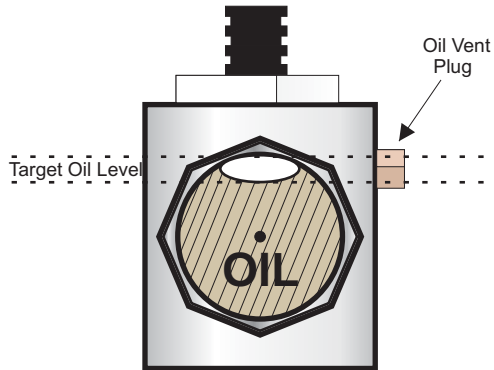

## Thermal Protection - QP Models

If the cooling fan were to fail or internal temperature were to reach 180°F the QP models are outfitted with a thermal fuse.

When tripped, the fuse can be reset. The canopy will need to be removed to reset the thermal fuse.



Press to  
Reset

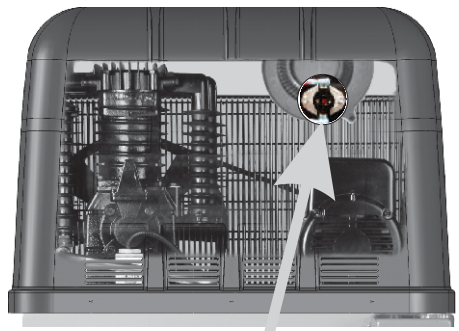

Location of Fuse  
(Inside Canopy  
Behind Fan)

## TROUBLESHOOTING GUIDE

<p>Low discharge pressure</p>	<ol style="list-style-type: none"> <li>1. Compressor too small for application</li> <li>2. Air leaks</li>   <li>3. Restricted intake air</li> <li>4. Blown gasket(s)</li> <li>5. Broken or misaligned valves</li> </ol>	<ol style="list-style-type: none"> <li>1. Reduce air demand or use a compressor with more air capacity.</li> <li>2. Listen for air leaks. Apply a soap solution to all fittings and connections. Bubbles will form at points of leakage. Tighten or replace fittings or connections.</li> <li>3. Clean or replace air filter.</li> <li>4. Replace necessary gaskets.</li> <li>5. Remove head and inspect for broken or misaligned valves. Replace valves, if necessary.</li> </ol> <p><b>⚠ CAUTION</b> Install a new head gasket each time head is removed</p>
<p>Excessive noise "knocking"</p>	<ol style="list-style-type: none"> <li>1. Loose drive pulley or flywheel</li> <li>2. Low on oil</li>   <li>3. Worn connecting rod or connecting rod bearing</li> <li>4. Noisy check valve</li> </ol>	<ol style="list-style-type: none"> <li>1. Tighten drive pulley or flywheel bolt.</li> <li>2. Check for proper oil level. Low or dirty oil may cause bearing damage.</li> <li>3. Replace connecting rod and/or connecting rod bearings.</li> <li>4. Replace check valve.</li> </ol> <p><b>⚠ DANGER</b> Do not remove check valve with air pressure in tank</p>
<p>Excessive oil carryover</p>	<ol style="list-style-type: none"> <li>1. Worn piston rings</li> <li>2. Restricted intake air</li> <li>3. Too much oil in compressor</li> <li>4. Incorrect oil viscosity</li> </ol>	<ol style="list-style-type: none"> <li>1. Replace with new piston rings.</li> <li>2. Clean or replace air filter.</li> <li>3. Drain oil to proper oil level.</li> <li>4. Use a quality non-detergent 30 or 40wt oil specified for each model (Page 4).</li> </ol>
<p>Water in tank and/or discharge line</p>	<ol style="list-style-type: none"> <li>1. Normal. Amount of water will increase as humidity in the air increases.</li> </ol>	<ol style="list-style-type: none"> <li>1. Drain tank at least once per day.</li> <li>2. Add an inline filter to reduce moisture in the air line.</li> </ol>
<p>Will not run or motor hums</p>	<ol style="list-style-type: none"> <li>1. Low voltage</li>   <li>2. Malfunctioning pressure switch</li> <li>3. Malfunctioning check valve</li> </ol>	<ol style="list-style-type: none"> <li>1. Check voltage with volt meter across both legs of incoming power. Check reset button on motor.</li> <li>2. Repair or replace pressure switch.</li> <li>3. Replace check valve or pressure switch.</li> </ol> <p><b>⚠ DANGER</b> Do not remove check valve with air pressure in tank</p>
<p>Breaker or reset repeatedly trips</p>	<ol style="list-style-type: none"> <li>1. Incorrect breaker size</li> <li>2. Low voltage</li>   <li>3. Malfunctioning motor</li> <li>4. Loose electrical connections</li> <li>5. Malfunctioning pressure switch</li> <li>6. Malfunctioning check valve</li> </ol>	<ol style="list-style-type: none"> <li>1. Make sure the breaker is sized properly. See page 6 in this manual.</li> <li>2. Check voltage with volt meter across both legs of incoming power.</li> <li>3. Replace motor.</li> <li>4. Check all electrical connections.</li> <li>5. Adjust or replace pressure switch.</li> <li>6. Replace check valve.</li> </ol> <p><b>⚠ DANGER</b> Do not remove check valve with air pressure in tank</p>
<p>Tank does not hold pressure when not running and shut off valve is closed</p>	<ol style="list-style-type: none"> <li>1. Malfunctioning check valve</li>   <li>2. Loose fittings or connections</li> <li>3. Crack or pin hole in tank</li> </ol>	<ol style="list-style-type: none"> <li>1. Replace check valve.</li> </ol> <p><b>⚠ DANGER</b> Do not remove check valve with air pressure in tank</p> <ol style="list-style-type: none"> <li>2. Tighten or replace fittings or connections.</li> <li>3. Replace tank. Do not attempt to repair tank.</li> </ol>



## TROUBLESHOOTING GUIDE (Continued)

<p>Pressure switch un-loader constantly leaking air</p>	<p>1. Malfunctioning check valve</p>	<p>1. Replace check valve if unloader bleeds constantly.</p> <p><b>⚠ DANGER</b> Do not remove check valve with air pressure in tank</p>
<p>Pressure switch not unloading</p>	<p>1. Malfunctioning pressure switch</p>	<p>1. Replace pressure switch if it does not release air pressure briefly when unit shuts off.</p> <p><b>⚠ DANGER</b> Do not remove pressure switch with air pressure in tank</p>
<p>Excessive vibration</p>	<p>1. Improper installation 2. Loose belts 3. Misaligned flywheel or drive pulley</p>	<p>1. Make sure unit is mounted on a level surface with vibration pads. 2. Replace belts. Align and tighten properly. 3. Align flywheel and drive pulley.</p>
<p>Overheating</p>	<p>1. Compressor too small for application 2. Cooling surfaces dirty 3. Improper cooling</p>	<p>1. Reduce air demand or use a compressor with more air capacity. 2. Clean all cooling surfaces of dirt and dust. 3. Install compressor in an area with adequate cool dry air.</p>

# Pump Specifications

Pump Model	Pump P/N	Cyl. No.	Stages
PAT24	4116091136	2	1
B3800	4116091337	2	1
T39	4116090019	2	2
T29S	4116090112	2	2
B5900	4116090137	2	2
C1	1312100706	2	2
C2	1312202700	4	2

Pump Model	Cyl. Diam. In. (mm)		Stroke in. (mm)	Max rpm	Oil Cap. Qt. (L)	Displacement @ max RPM	
	1st Stg	2nd Stg				CFM	L/M
PAT24	2.48 (63)	N/A	1.50 (38)	1400	.56 (0.53)	11.71	331.59
PAT38	2.48 (63)	N/A	2.36 (60)	1400	.91 (.86)	18.49	523.58
T39	4.13 (105)	2.05 (52)	2.95 (60)	1400	1.09 (1.03)	32.02	906.63
T29S	3.74 (85)	1.97 (45)	1.97 (45)	1400	1.44 (1.36)	17.53	496.50
B5900	4.13 (105)	2.16 (55)	2.16 (55)	1400	1.72 (1.63)	23.44	663.84
C1	4.13 (105)	2.16 (55)	3.5 (89)	1000	1.31 (1.24)	27.13	768.33
C2	4.13 (105)	2.16 (55)	3.5 (89)	900	1.5 (1.42)	48.84	1382.99

Pump Model	Bolt Torque Ft.-Lbs. (NM)				
	Conrod	Head	Cylinder	Bearing Housing	Flywheel
PAT24	N/A	18-20 (24-27)	18-20 (24-27)	5-7 (7-10)	18-20 (24-27)
PAT38	N/A	18-20 (24-27)	18-20 (24-27)	5-7 (7-10)	18-20 (24-27)
T39	20-22 (27-30)	30-33 (40-45)	16-19 (22-26)	19-22 (26-30)	34-37 (46-50)
T29S	18-20 (24-27)	18-20 (24-27)	18-20 (24-27)	5-7 (7-10)	18-20 (24-27)
B5900	18-20 (24-27)	18-20 (24-27)	18-20 (24-27)	5-7 (7-10)	18-20 (24-27)
C1	34-37 (46-50)	34-37 (46-50)	19-27 (26-37)	14-19 (19-26)	47-57 (64-77)
C2	34-37 (46-50)	34-37 (46-50)	19-27 (26-37)	14-19 (19-26)	47-57 (64-77)

# Tank Specifications

Volume		Max Pressure		Discharge Conn.
Gal.	Liter	PSI	Bar	NPT
20H	76	150	10.345	1/4"
26V	99	150	10.345	1/4"
60V	228	170	11.724	1/2"
2X4	2X15.2	200	13.793	3/8"
2X5	2X19	200	13.793	3/8"
80H	228	200	13.793	3/4"
80V	300	200	13.793	3/4"
30H	114	200	13.793	3/4"
120V	456	200	13.793	3/4"
120H	456	200	13.793	3/4"
120D	456	200	13.793	3/4"
200D	760	200	13.793	3/4"



## WARNING

Oil and moisture residue must be drained from the air receiver daily or after each use. Accumulations of oil residue in the receiver can be ignited by embers of carbon created by the heat of compression - causing an explosion, damage to property and injury to personnel



## WARNING

Do not open a manual tank drain valve on any air tank containing more than 30 PSIG of air pressure!



## WARNING

Never attempt to relieve an air tank by removing a pipe plug or any other system component!

### Manually Draining An Air Tank:

- Step 1)** Disconnect & lockout the compressor from the power source (electric models) or disconnect the spark plug wire from the spark plug (gas engine models).
- Step 2)** Tank(s) subjected to freezing temperatures may contain ice. Store the compressor in a heated area before attempting to drain moisture from the tank(s). Reduce the air pressure in the tank to 30 PSIG by pulling the pressure relief valve ring (refer to **Fig. 3-4, Checking Pressure Relief Valves & Relieving System Pressure**).
- Step 3)** Slowly open the drain valve and allow the moisture and air mixture to drain from the tank.
- Step 4)** Once the moisture has been completely drained, close the drain valve.

**Air Tank Inspection**

Tank Capacity	Horizontal or Vertical	Minimum Allowable Wall		Visually Inspect	Hydrostatically Inspect
		HEAD	SHELL		
8 Gal.	Horizontal	0.096	0.094	Yearly	10 Years
8 Gal.	Twin Horz.	0.098	0.098	Yearly	10 Years
10 Gal.	Twin Horz.	0.118	0.118	Yearly	10 Years
20 Gal.	Horizontal	0.094	0.094	Yearly	10 Years
26 Gal.	Vertical	0.094	0.094	Yearly	10 Years
30 Gal.	Horizontal	0.109	0.098	Yearly	10 Years
60 Gal.	Vertical	0.094	0.094	Yearly	10 Years
80 Gal.	Vertical	0.149	0.133	Yearly	10 Years
80 Gal.	Horizontal	0.109	0.133	Yearly	10 Years
120 Gal.	Vertical	0.163	0.199	Yearly	10 Years
120 Gal. & Duplex	Horizontal	0.131	0.159	Yearly	10 Years
200 Gal. Duplex	Horizontal	0.163	0.199	Yearly	10 Years

The factory recommends that all air tanks be inspected at scheduled intervals. Refer to **Recommended Air Tank Inspection Intervals Table** for relative information.

**Refer to federal, state or provincial, or local codes for mandatory air tank maintenance information.**

# Part Callouts

## Electric

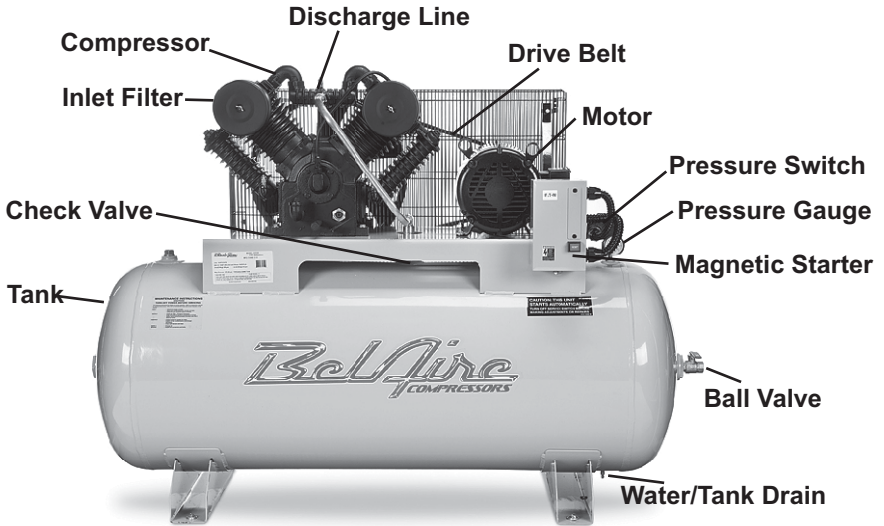

## Gas Drive

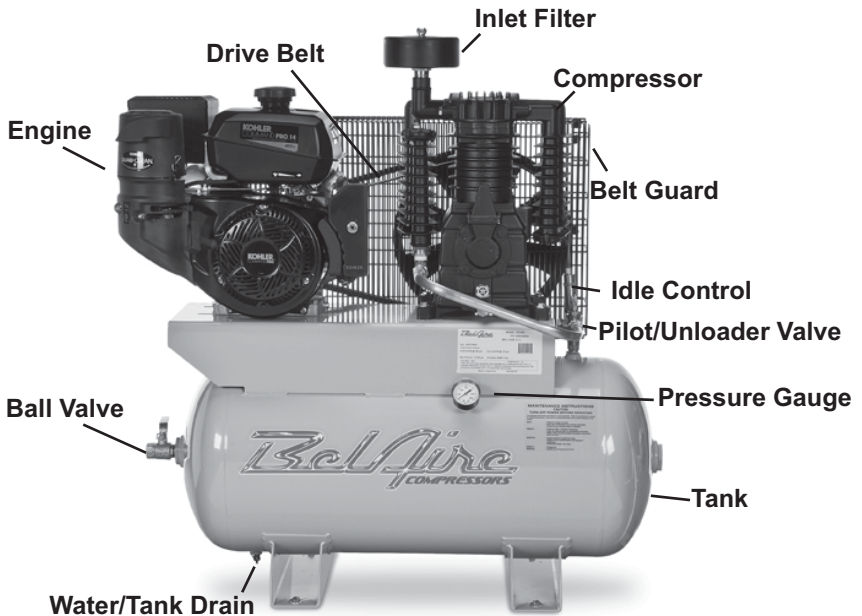

# Single Stage

\*Note: Verify Model and Part Number of Machine Before Ordering  
Change has been made to Compressor Pumps (March-April 2014)

	5020P*	5026VP*	2061V*	6061V*
<b>Compressor</b>	4116091336	4116091336	4116091337	4116091337
<b>Motor</b>	1312100388	1312100388	1312100388	1312100390
<b>Tank</b>	1312100473	1312100475	1312100460	1312100460
<b>Check Valve</b>	1312100170	1312100170	1312100170	1312100170
<b>Pressure Switch</b>	1312100455	1312100455	1312100455	1312100455
<b>Safety Valve</b>	1312100005	1312100005	1312100005	1312100005
<b>Pressure Gauge</b>	1312100006	1312100006	1312100840	1312100840
<b>Discharge Line</b>	1312101048	1312101048	1312101047	1312101047
<b>Inlet Filter</b>	2236111635	2236111635	2236111635	2236111635
<b>Water Drain</b>	1312100360	1312100360	1312100360	1312100360
<b>BeltGuard (front)</b>	6214343100	6214343100	6214343100	6214343100
<b>BeltGuard (back)</b>	2236110472	2236110472	2236110472	2236110472
<b>Drive Pulley</b>	1312100439	1312100439	1312101154	1312101070
<b>Drive Belt</b>	1312101067	1312101067	1312100132	1312100807
<b>Unloader Line</b>	1312100026	1312100026	1312100026	1312100026
<b>Power Cord</b>	1312100007	1312100007	N/A	N/A
<b>Wheel</b>	1312100060	1312100029	N/A	N/A
<b>Handle</b>	2236107285	2236107294	N/A	N/A

\*Model 5020P (Part# 8090254163)  
Model 5026VP (Part# 8090254106)  
Model 2061V (Part# 8090254064)  
Model 6061V (Part# 8090254007)

\*Model T2030 (Part# 8090254239)

## Contractor

\*Model TH5530 (Part# 8090254262)  
Model TR6030 (Part# 8090254296)

ELECTRIC	
	T2030
<b>Compressor</b>	4116091337
<b>Motor</b>	1312100388
<b>Tank</b>	1312100521
<b>Check Valve</b>	1312100170
<b>Pressure Switch</b>	1312100455
<b>Safety Valve</b>	1312100005
<b>Pressure Gauge</b>	1312100845
<b>Discharge Tube</b>	1312101156
<b>Ball Valve</b>	1312100181
<b>Inlet Filter</b>	2236111635
<b>Tank Drain</b>	1312100360
<b>Unloader Line</b>	1312100026
<b>BeltGuard (front)</b>	1312100146
<b>BeltGuard (back)</b>	1312100147
<b>Belt Guard Fastener</b>	1312100076
<b>Drive Pulley</b>	1312101154
<b>Drive Belt</b>	1312100129
<b>Wheel</b>	1312100461
<b>Power Cord</b>	1312100007

GAS DRIVE					
	TH5530	TR6030	TR908	TH908	TK128-I
<b>Compressor</b>	4116091337	4116091337	4116090019	4116090019	4116090019
<b>Engine</b>	1312100219	1312100230	1312100231	1312100221	1312101114
<b>Tank</b>	1312100521	1312100521	1312100520	1312100520	1312100520
<b>Idle Control</b>	1312100382	1312100382	1312100382	1312100382	1312100571
<b>Unloader/Pilot Valve</b>	1312100496	1312100496	1312100495	1312100495	1312100495
<b>Safety Valve</b>	1312100005	1312100005	9710533300	9710533300	9710533300
<b>Pressure Gauge</b>	1312100845	1312100845	1312100845	1312100845	1312100845
<b>Discharge Tube</b>	1312101160	1312101160	1312100204	1312100204	1312100204
<b>Ball Valve</b>	1312100161	1312100161	1312100161	1312100161	1312100161
<b>Inlet Filter</b>	2236111635	2236111635	1312100374	1312100374	1312100374
<b>Tank Drain</b>	1312100360	1312100360	1312100360	1312100360	1312100360
<b>BeltGuard (front)</b>	1312100146	1312100146	1312100150	1312100150	1312100150
<b>BeltGuard (back)</b>	1312100147	1312100147	1312100149	1312100149	1312100149
<b>Belt Guard Fastener</b>	1312100076	1312100076	1312100076	1312100076	1312100076
<b>Drive Pulley</b>	1312101070	1312101070	1312100419	1312100419	1312100419
<b>Drive Belt</b>	1312100131	1312100131	1312100136	1312100137	1312100136
<b>Wheel</b>	1312100461	1312100461	1312100461	1312100461	1312100461

# Two Stage Electric

	216V	218V	318VN	318V	318H	338V/4	338H/4	318VE	318HE	338VE/4	
<b>Pump</b>	411609012	411609012	4116090019	4116090019	4116090019	4116090019	4116090019	4116090019	4116090019	4116090019	
<b>Motor</b>	1312100087	1312100389	1312100389	1312100389	1312100389	1312101602	1312101602	1312100389	1312100389	1312101602	
<b>Tank</b>	1312100460	1312101018	1312101018	1312101018	1312100485	1312101018	1312100485	1312101018	1312100485	1312101018	
<b>Check Valve</b>	1312100170	1312100170	1312100171	1312100171	1312100171	1312100171	1312100171	1312100171	1312100171	1312100171	
<b>Pressure Switch</b>	1312100459	1312100570	1312100570	1312100570	1312100570	1312100570	1312100570	1312100570	1312100570	1312100570	
<b>Safety Valve</b>	1310251870	9710533300	9710533300	9710533300	9710533300	9710533300	9710533300	9710533300	9710533300	9710533300	
<b>Pressure Gauge</b>	1312100840	1312100845	1312100845	1312100845	1312100845	1312100845	1312100845	1312100845	1312100845	1312100845	
<b>Discharge Line</b>	1312100214	1312100200	1312100198	1312100198	1312100199	1312100198	1312100199	1312100198	1312100199	1312100198	
<b>Ball Valve</b>	1312100162	1312100163	1312100163	1312100163	1312100163	1312100163	1312100163	1312100163	1312100163	1312100163	
<b>Inlet Filter</b>	1312100376	1312100376	1312100374	1312100374	1312100374	1312100374	1312100374	1312100374	1312100374	1312100374	
<b>Water Drain</b>	1312100360	1312100360	1312100360	1312100360	1312100360	1312100360	1312100360	1312100360	1312100360	1312100360	
<b>Belt Guard (Front)</b>	1312100146	1312100150	1312100150	1312100150	1312100150	1312100150	1312100150	1312100150	1312100150	1312100150	
<b>Belt Guard (Back)</b>	1312100145	1312100148	1312100148	1312100148	1312100148	1312100148	1312100148	1312100148	1312100148	1312100148	
<b>Belt Guard Clip</b>	1312100076	1312100076	1312100076	1312100076	1312100076	1312100076	1312100076	1312100076	1312100076	1312100076	
<b>Drive Pulley</b>	1312100442	1312100442	1312100418	1312100422	1312100422	1312100422	1312100422	1312100422	1312100422	1312100422	
<b>Drive Belt</b>	1312100133	1312100137	1312100137	1312100140	1312100140	1312100140	1312100140	1312100140	1312100140	1312100140	
<b>Magnetic Starter</b>	No Starter Req.	No Starter Req.	No Starter Req.	No Starter Req.	No Starter Req.	No Starter Req.	No Starter Req.	No Starter Req.	No Starter Req.	No Starter Req.	
Single Phase (208V-230V)	N/A	N/A	N/A	N/A	1312100659	1312100659	N/A	N/A	1312100659	1312100659	N/A
Three Phase (208-230V)	N/A	N/A	N/A	N/A	N/A	N/A	1312100656	1312100656	N/A	N/A	1312100656
Three Phase (460V)	N/A	N/A	N/A	N/A	N/A	N/A	1312100654	1312100654	N/A	N/A	1312100654
<b>AfterCooler</b>	Pump Mounted	Pump Mounted	Pump Mounted	Pump Mounted	Pump Mounted	Pump Mounted	Pump Mounted	Pump Mounted	Pump Mounted	Pump Mounted	
Low Oil Level Switch	N/A	N/A	N/A	N/A	N/A	N/A	N/A	1310711181	1310711181	1310711181	
Auto Tank Drain	N/A	N/A	N/A	N/A	N/A	N/A	N/A	1312100110	1312100110	1312100110	
Beltguard Aftercooler	N/A	N/A	N/A	N/A	N/A	N/A	N/A	N/A	N/A	N/A	

	338HE/4	318VL	318HL	338VL/4	338HL/4	318VLE	318HLE	338VLE/4	338HLE/4
<b>Pump</b>	4116090019	4116090019	4116090019	4116090019	4116090019	4116090019	4116090019	4116090019	4116090019
<b>Motor</b>	1312101602	1312100400	1312100400	1312101601	1312101601	1312100400	1312100400	1312101601	1312101601
<b>Tank</b>	1312100485	1312101018	1312100485	1312101018	1312100485	1312101018	1312100485	1312101018	1312100485
<b>Check Valve</b>	1312100171	1312100171	1312100171	1312100171	1312100171	1312100171	1312100171	1312100171	1312100171
<b>Pressure Switch</b>	1312100570	1312100570	1312100570	1312100570	1312100570	1312100570	1312100570	1312100570	1312100570
<b>Safety Valve</b>	9710533300	9710533300	9710533300	9710533300	9710533300	9710533300	9710533300	9710533300	9710533300
<b>Pressure Gauge</b>	1312100845	1312100845	1312100845	1312100845	1312100845	1312100845	1312100845	1312100845	1312100845
<b>Discharge Line</b>	1312100199	1312100198	1312100199	1312100198	1312100199	1312100198	1312100199	1312100198	1312100199
<b>Ball Valve</b>	1312100163	1312100163	1312100163	1312100163	1312100163	1312100163	1312100163	1312100163	1312100163
<b>Inlet Filter</b>	1312100374	1312100374	1312100374	1312100374	1312100374	1312100374	1312100374	1312100374	1312100374
<b>Water Drain</b>	1312100360	1312100360	1312100360	1312100360	1312100360	1312100360	1312100360	1312100360	1312100360
<b>Belt Guard (Front)</b>	1312100150	1312100150	1312100150	1312100150	1312100150	1312100150	1312100150	1312100150	1312100150
<b>Belt Guard (Back)</b>	1312100148	1312100148	1312100148	1312100148	1312100148	1312100148	1312100148	1312100148	1312100148
<b>Belt Guard Clip</b>	1312100076	1312100076	1312100076	1312100076	1312100076	1312100076	1312100076	1312100076	1312100076
<b>Drive Pulley</b>	1312100422	1312100420	1312100420	1312100420	1312100420	1312100420	1312100420	1312100420	1312100420
<b>Drive Belt</b>	1312100140	1312100139	1312100139	1312100139	1312100139	1312100139	1312100139	1312100139	1312100139
<b>Magnetic Starter</b>									
Single Phase (208V-230V)	N/A	1312100662	1312100662	N/A	N/A	1312100662	1312100662	N/A	N/A
Three Phase (208-230V)	1312100656	N/A	N/A	1312100658	1312100658	N/A	N/A	1312100658	1312100658
Three Phase (460V)	1312100654	N/A	N/A	1312100657	1312100657	N/A	N/A	1312100657	1312100657
<b>AfterCooler</b>	Pump Mounted	Pump Mounted	Pump Mounted	Pump Mounted	Pump Mounted	Pump Mounted	Pump Mounted	Pump Mounted	Pump Mounted
Low Oil Level Switch	1310711181	N/A	N/A	N/A	N/A	1310711181	1310711181	1310711181	1310711181
Auto Tank Drain	1312100110	N/A	N/A	N/A	N/A	1312100110	1312100110	1312100110	1312100110
Beltguard Aftercooler	N/A	N/A	N/A	N/A	N/A	N/A	N/A	N/A	N/A

# Gas Drive and Duplex

## Gas Drive

	59G3HR	59G3HB	3G3HH	3G3HK	3G3HKL	3G3HHL
<b>Compressor</b>	4116090137	4116090137	4116090019	4116090019	4116090019	4116090019
<b>Engine</b>	1312100232	1312100730	1312100223	1312100998	1312100998	1312100224
<b>Tank</b>	1312100479	1312100479	1312100479	1312100479	1312100479	1312100479
<b>Unloader Valve</b>	1312100497	1312100497	1312100497	1312100497	1312100497	1312100497
<b>Safety Valve</b>	9710533300	9710533300	9710533300	9710533300	9710533300	9710533300
<b>Pressure Gauge</b>	1312100845	1312100845	1312100845	1312100845	1312100845	1312100845
<b>Discharge Line</b>	1312100209	1312100209	1312100217	1312100208	1312100217	1312100217
<b>Ball Valve</b>	1312100163	1312100163	1312100163	1312100163	1312100163	1312100163
<b>Inlet Filter</b>	6211471600	6211471600	1312100374	1312100374	1312100374	1312100374
<b>Tank Drain</b>	1312100361	1312100361	1312100361	1312100361	1312100361	1312100361
<b>BeltGuard (front)</b>	1312100150	1312100150	1312100150	1312100150	1312100150	1312100150
<b>BeltGuard (back)</b>	1312100149	1312100149	1312100149	1312100149	1312100149	1312100149
<b>Belt</b>	1312100136	1312100137	1312100120	1312100120	1312100120	1312100121
<b>Beltguard Clip</b>	1312100076	1312100076	1312100076	1312100076	1312100076	1312100076
<b>Unloader Line</b>	1312100373	1312100373	1312100373	1312100373	1312100373	1312100373
<b>Idle Control</b>	1312100382	1312100742	1312100382	1312100099	1312100099	1312100382
<b>Drive Pulley</b>	1312100443	1312100443	1312100419	1312100419	1312100444	1312100421

	4G3HH	4G3HHL	4G3HKL	6G3HV
<b>Cast Iron Units</b>				
<b>Compressor</b>	1312202800	1312202800	1312202800	1312202700
<b>Engine</b>	1312100223	1312100224	1312101114	1312100731
<b>Tank</b>	1312100479	1312100479	1312100479	1312101113
<b>Unloader Valve</b>	1312101115	1312101115	1312101115	1312100497
<b>Safety Valve</b>	9710533300	9710533300	9710533300	9710533300
<b>Pressure Gauge</b>	1312100845	1312100845	1312100845	1312100845
<b>Discharge Line</b>	1312101101	1312101101	1312101101	1312100720
<b>Ball Valve</b>	1312100163	1312100163	1312100163	1312100162
<b>Inlet Filter</b>	1312100374	1312100374	1312100374	1312100374
<b>Tank Drain</b>	1312100361	1312100361	1312100361	1312100360
<b>BeltGuard</b>	1312101093	1312101093	1312101093	1312204300
<b>Belt</b>	1312100993	1312101138	1312101138	1312100736
<b>Beltguard Clip</b>	1312101027	1312101027	1312101027	1312100360
<b>Unloader Line</b>	1312100373	1312100373	N/A	N/A
<b>Idle Control</b>	1312101049	1312101049	1312100099	1312100741
<b>Drive Pulley</b>	1312100711	1312101040	1312101040	1312100711

## Duplex

	3112D	3312D	3312D4	3112DL	3312DL	3312DL4	3120DL	3320DL	3320DL4
<b>Compressor</b>	4116090019	4116090019	4116090019	4116090019	4116090019	4116090019	4116090019	4116090019	4116090019
<b>Motor</b>	1312100399	1312101602	1312101602	1312100400	1312101601	1312101601	1312100400	1312101601	1312101601
<b>Tank</b>	1312100463	1312100463	1312100463	1312100463	1312100463	1312100463	1312100665	1312100665	1312100665
<b>Check Valve</b>	1312100171	1312100171	1312100171	1312100171	1312100171	1312100171	1312100171	1312100171	1312100171
<b>Pressure Switch</b>	1312100570	1312100570	1312100570	1312100570	1312100570	1312100570	1312100570	1312100570	1312100570
<b>Safety Valve</b>	9710533300	9710533300	9710533300	9710533300	9710533300	9710533300	9710533300	9710533300	9710533300
<b>Pressure Gauge</b>	1312100845	1312100845	1312100845	1312100845	1312100845	1312100845	1312100845	1312100845	1312100845
<b>Discharge Line</b>	1312100211(Lt.) 1312100212(Rt.)	1312100211(Lt.) 1312100212(Rt.)	1312100211(Lt.) 1312100212(Rt.)	1312100211(Lt.) 1312100212(Rt.)	1312100211(Lt.) 1312100212(Rt.)	1312100211(Lt.) 1312100212(Rt.)	1312100211(Lt.) 1312100212(Rt.)	1312100211(Lt.) 1312100212(Rt.)	1312100211(Lt.) 1312100212(Rt.)
<b>Ball Valve</b>	1312100160	1312100160	1312100160	1312100160	1312100160	1312100160	1312100160	1312100160	1312100160
<b>Inlet Filter</b>	1312100374	1312100374	1312100374	1312100374	1312100374	1312100374	1312100374	1312100374	1312100374
<b>Filter Element</b>	FE001	FE001	FE001	FE001	FE001	FE001	FE001	FE001	FE001
<b>Water Drain</b>	1312100360	1312100360	1312100360	1312100360	1312100360	1312100360	1312100360	1312100360	1312100360
<b>Belt Guard (Front)</b>	1312100150	1312100150	1312100150	1312100150	1312100150	1312100150	1312100150	1312100150	1312100150
<b>Belt Guard (Back)</b>	1312100149(Rt.) 1312100148(Lt.)	1312100149(Rt.) 1312100148(Lt.)	1312100149(Rt.) 1312100148(Lt.)	1312100149(Rt.) 1312100148(Lt.)	1312100149(Rt.) 1312100148(Lt.)	1312100149(Rt.) 1312100148(Lt.)	1312100149(Rt.) 1312100148(Lt.)	1312100149(Rt.) 1312100148(Lt.)	1312100149(Rt.) 1312100148(Lt.)
<b>Drive Belt</b>	1312100140	1312100140	1312100140	1312100139	1312100139	1312100139	1312100139	1312100139	1312100139
<b>Drive Pulley</b>	1312100422	1312100422	1312100422	1312100420	1312100420	1312100420	1312100420	1312100420	1312100420
<b>Unloader Line</b>	1312100373	1312100373	1312100373	1312100373	1312100373	1312100373	1312100373	1312100373	1312100373
<b>Magnetic Starter</b>	1312100659	1312100656	1312100654	1312100662	1312100658	1312100657	1312100662	1312100658	1312100657
<b>Alternator</b>	1312100111	1312100111	1312100112	1312100111	1312100111	1312100112	1312100111	1312100111	1312100112



# QP

	QP318VE	QP338VE	QP318VLE	QP338VLE
Compressor	4116090019	4116090019	4116090019	4116090019
Motor	1312100399	1312100602	1312100400	1312101601
Tank	1312101018	1312101018	1312101018	1312101018
Check Valve	1312100171	1312100171	1312100171	1312100171
Press. Switch	1312100570	1312100570	1312100570	1312100570
Safety Valve	9710533300	9710533300	9710533300	9710533300
Press. Gauge	1312100845	1312100845	1312100845	1312100845
Mag. Starter	1312100659	1312100656	1312100662	1312100658
Canopy	1312202180	1312202180	1312202180	1312202180
Tank Drain	1312100110	1312100110	1312100110	1312100110
Ball Valve	1312100163	1312100163	1312100163	1312100163
Disch. Line	1312100198	1312100198	1312100198	1312100198
Inlet Filter	1312100097	1312100097	1312100097	1312100097
Low Oil Switch	1310711181	1310711181	1310711181	1310711181
Blower	1312100088	1312100088	1312100088	1312100088
Belt Guard (Back)	1312100148	1312100148	1312100148	1312100148
Belt Guard (Front)	1312100150	1312100150	1312100150	1312100150
Belt	1312100140	1312100140	1312100139	1312100139
Belt Guard Clip	1312100076	1312100076	1312100076	1312100076
Unloader Line	1312100373	1312100373	1312100373	1312100373
Drive Pulley	1312100422	1312100422	1312100420	1312100420
High Temp Switch	1312100089	1312100089	1312100089	1312100089

# Iron Series

	418VE	438VE/4	418V	438V/4
Compressor	1312100706	1312100706	1312100706	1312100706
Motor	1312100399	1312101602	1312100399	1312101602
Belt Guard	1312100982	1312100982	1312100982	1312100982
Discharge Line (Top)	1312101101	1312101101	1312100994	1312100994
Discharge Line (Btm)	1312101102	1312101102		
Pressure Switch	1312100570	1312100570	1312100570	1312100570
Ball Valve	1312100163	1312100163	1312100163	1312100163
Unloader Line	1312100026	1312100026	1312100026	1312100026
Safety Valve	9710533300	9710533300	9710533300	9710533300
Pressure Gauge	1312100845	1312100845	1312100845	1312100845
Tank	1312101018	1312101018	1312101018	1312101018
Tank Drain	1312100110	1312100110	1312100360	1312100360
Magnetic Starter	1312100659	1312100656 (208-230V) 1312100654 (460V)	1312100659	1312100656 (208-230V) 1312100654 (460V)
Drive Pulley	1312100714	1312100714	1312100714	1312100714
Bushing	1312100445	1312100445	1312100445	1312100445
Belt	1312100993	1312100993	1312100993	1312100993
Check Valve	1312100167	1312100167	1312100169	1312100169
Aftercooler	1312100611	1312100611		
Low Oil Switch	1312100014	1312100014		
LOS - Housing	1312100013	1312100013		
	418VLE	438VLE/4	418VL	438VL/4
Compressor	1312100706	1312100706	1312100706	1312100706
Motor	1312100400	1312101601	1312100400	1312101601
Belt Guard	1312100982	1312100982	1312100982	1312100982
Discharge Line (Top)	1312101101	1312101101	1312100994	1312100994
Discharge Line (Btm)	1312101102	1312101102		
Pressure Switch	1312100570	1312100570	1312100570	1312100570
Ball Valve	1312100163	1312100163	1312100163	1312100163
Unloader Line	1312100026	1312100026	1312100026	1312100026
Safety Valve	9710533300	9710533300	9710533300	9710533300
Pressure Gauge	1312100845	1312100845	1312100845	1312100845
Tank	1312101018	1312101018	1312101018	1312101018
Tank Drain	1312100110	1312100110	1312100360	1312100360
Magnetic Starter	1312100662	1312100658 (208-230V) 1312100657 (460V)	1312100662	1312100658 (208-230V) 1312100657 (460V)
Drive Pulley	1312100938	1312100938	1312100938	1312100938
Bushing	1312100445	1312100445	1312100445	1312100445
Belt	1312100939	1312100939	1312100939	1312100939
Check Valve	1312100167	1312100167	1312100169	1312100169
Aftercooler	1312100611	1312100611		
Low Oil Switch	1312100014	1312100014		
LOS - Housing	1312100013	1312100013		
	6312V/4	6312H/4	6312VE/4	6312HE/4
Compressor	1312202700	1312202700	1312202700	1312202700
Motor	1312101600	1312101600	1312101600	1312101600
Belt Guard	1312100983	1312100983	1312100983	1312100983
Discharge Line	1312100717	1312100717	1312100959 (top) 1312100960 (btm)	1312100959 (top) 1312100961 (btm)
Ball Valve	1312100570	1312100570	1312100163	1312100163
Pressure Switch	1312100163	1312100163	1312100570	1312100570
Unloader Line	1312100026	1312100026	1312100026	1312100026
Safety Valve	9710533300	9710533300	9710533300	9710533300
Pressure Gauge	1312100845	1312100845	1312100845	1312100845
Tank	1312100469	1312100465	1312100469	1312100465
Tank Drain	1312100360	1312100360	1312100110	1312100110
Magnetic Starter	1312100661 (208-230V) 1312100657 (460V)	1312100661 (208-230V) 1312100657 (460V)	1312100661 (208-230V) 1312100657 (460V)	1312100661 (208-230V) 1312100657 (460V)
Drive Pulley	1312100713	1312100713	1312100713	1312100713
Bushing	1312100446	1312100446	1312100446	1312100446

# Compressor Pump 4116091336 (PAT24) and 4116091337 (PAT38)

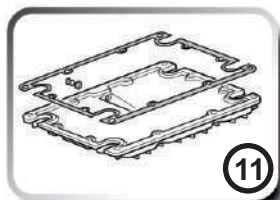
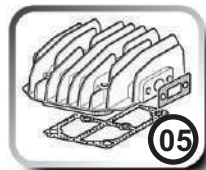
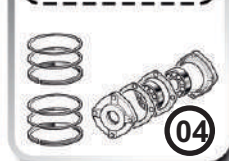
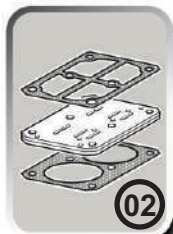
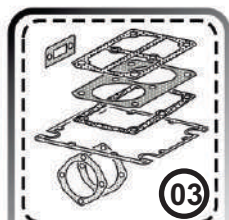
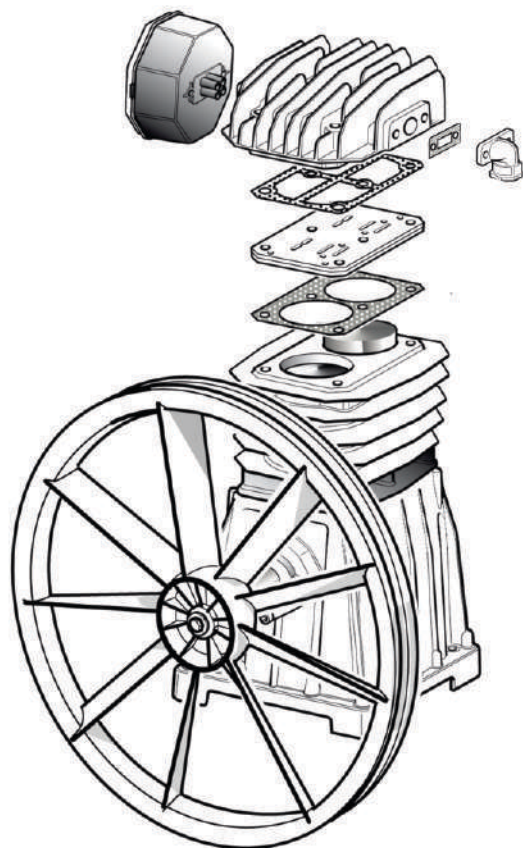

# Compressor Pump 4116091336 (PAT24) and 4116091337 (PAT38)

01	Air Filter Kit	2236111635
02	Valve Assembly Kit	2236112518
03	Gasket Kit	2901325045
04	Bearing and Ring Kit	2901325046
05	Head Kit	2901325044
06	Discharge Elbow Kit	2901325047
07	Cylinder Kit	2236112434(PAT24) 2236112435(PAT38)
08	Oil Level Kit	6229021000
09	Conrod Kit	2236111619(PAT24) 2236111620(PAT38)
10	Flywheel Kit	6229023400(PAT24) 2901325048(PAT38)
11	Crankcase Bottom Kit	2236112437(PAT24) 2236112438(PAT38)

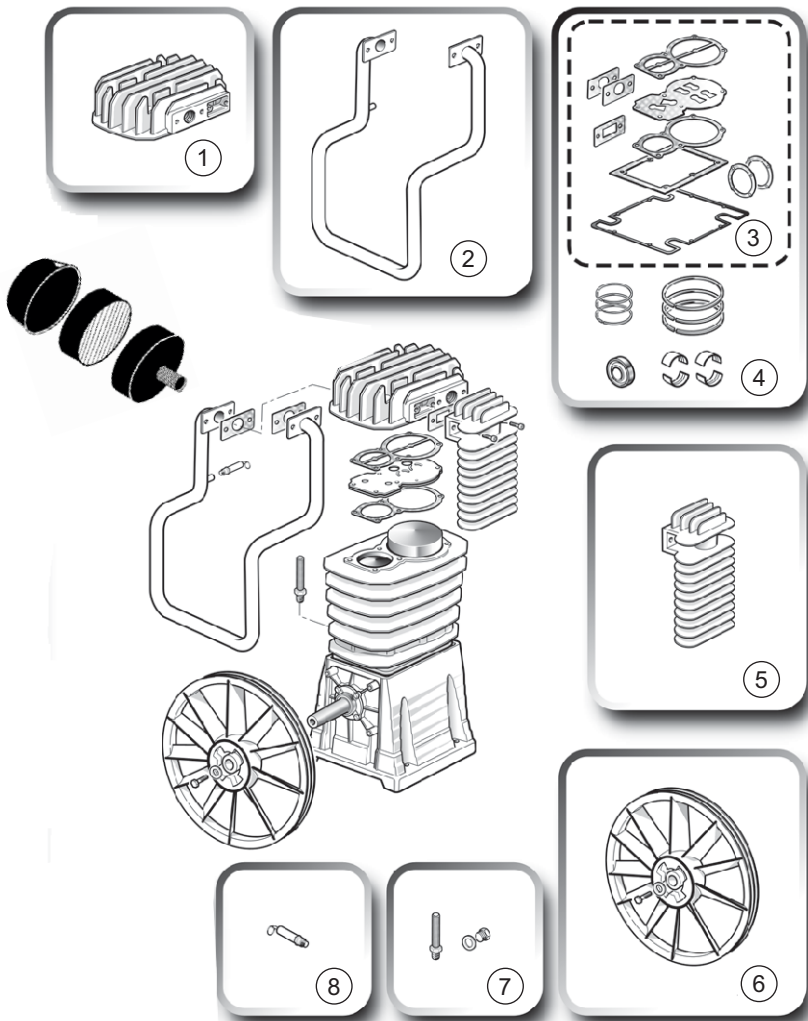

Ill. No.	Part Number	Description
1	2901324960	Head Kit
2	2901324961	Intercooler Kit
3	8973035118	Gasket Kit
4	6229017300	Overhaul Kit
5	2901324962	Aftercooler Kit
6	6229017600	Flywheel Kit
7	2901324950	Oil Level Kit
8	2901324963	65 psi Safety Valve
	1312100376	Filter Assembly
	FE004	Filter Element
	2236102992	Oil Sight Glass
	6211848600	Flywheel Bolt
	6214242800	Flywheel Washer
	6210717280	Valve Assembly

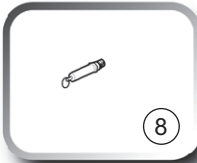
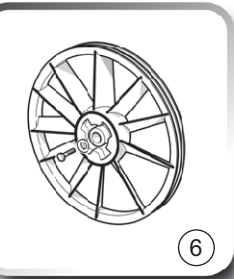
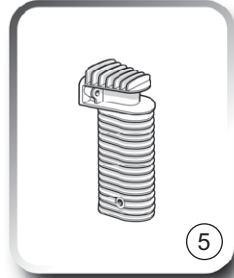
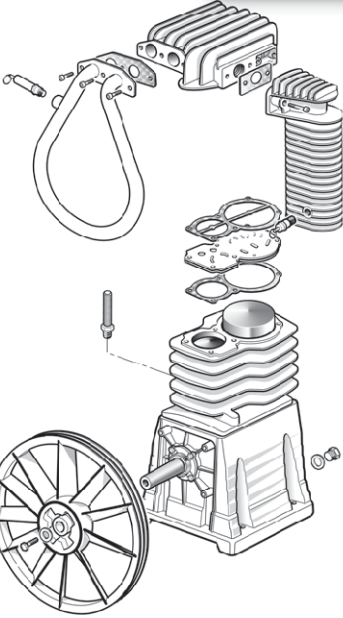
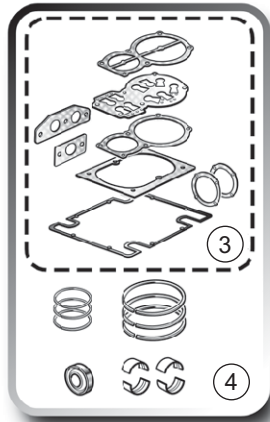
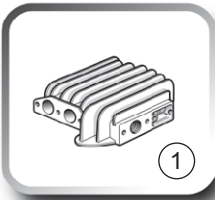

Ill. No.	Part Number	Description
1	2901324964	Head Kit
2	2901324965	Intercooler Kit
3	8973037264	Gasket Kit
4	6229026900	Overhaul Kit
5	2901324966	Aftercooler Kit
6	6229020100	Flywheel Kit
7	2901324951	Oil Level Kit
8	2901324963	65 psi Safety Valve
	2901324974	217 psi Safety Valve
	6211471600	Filter Assembly
	8973035122	Filter Element
	6214341200	Oil Sight Glass
	6211848500	Flywheel Bolt
	6214242700	Flywheel Washer
	6210716900	Valve Assembly

**B5900**  
**(4116090137)**

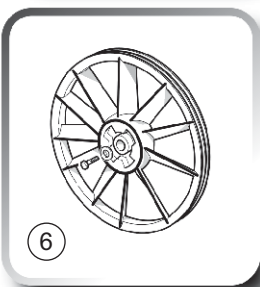
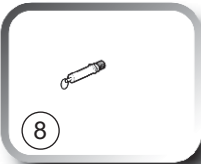
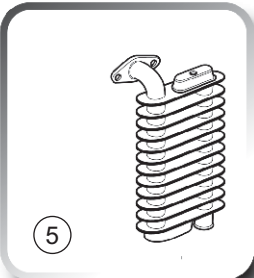
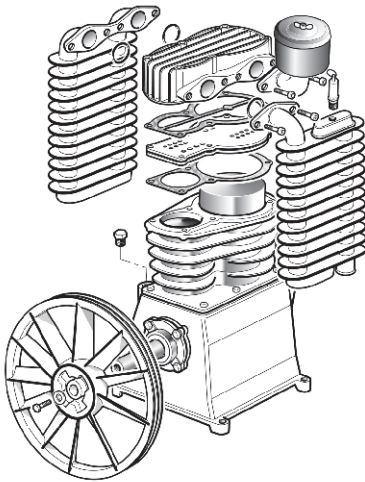
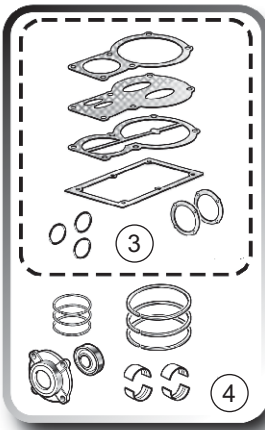
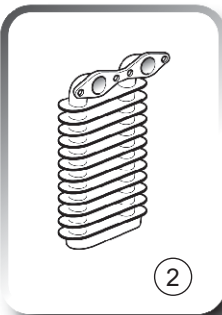
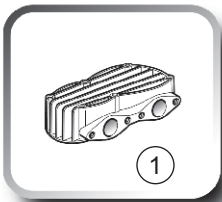

Ill. No.	Part Number	Description
1	2901324971	Head Kit
2	2901324972	Intercooler Kit
3	1310711137	Gasket Kit
4	1310711168	Overhaul Kit
5	2901324973	Aftercooler Kit
6	6229018800	Flywheel Kit
7	2901324954	Oil Level Kit
8	1312100456	225 psi Safety Valve
	1312100374*	Filter Assembly
	FE001*	Filter Element
	2236102992	Oil Sight Glass
	6211848500	Flywheel Bolt
	6214242700	Flywheel Washer
	2901324723	Valve Kit
*QP Models	1312100097	Filter Assembly
	FE004	Filter Element

**T39**  
**(4116090019)**





# CA1

## (1312202800)

Item	Description	Qty	Part #
1	Crankcase	1	1312100876
2	Crank Shaft	1	1312100932
3	Fly Wheel	1	1312100884
4	Cylinder	1	1312100880
5	Head	1	1312100878
6	Oil Sight Glass	1	1312100903
7	Oil Drain Pipe	1	1312100859
8	Oil Drain Pipe Cap	1	1312100861
9	Oil Fill Elbow	1	1312100933
10	Plug	4	1312100866
11	Spacer - Inlet Valve	2	1312100893
12	Spacer Discharge Valve	3	1312100894
13	Breather Body	1	1312100934
14	Copper Connector	1	1312100860
15	Copper Nut	2	1312100856
16	Cover-Centrifugal Unloader	1	1312100899
17	Valve Assy HP/LP Discharge	2	1312100892
18	Retainer Inlet Valve	1	1312100898
19	Capscrew-Hex M8x25	21	0147132503
20	Lockwasher 8	8	0333222500
21	Retainer Inlet Valve	1	1312100895
22	Gasket Rear Cap	1	1312100920
23.1	Shim 0.20 Brg. Adj.	1	1312100930
23.2	Shim 0.10 Brg. Adj.	2	1312100929
24	Retainer Discharge Valve	3	1312100896
25	Copper Elbow	1	1312100857
26	Gasket Side Cover	1	1312100916
27	Cover Crankcase Side	1	1312100858
28	Copper Gasket	14	1312100921
29	Gasket Front Cap	1	1312100915
30	Bearing Cap Rear	1	1312100909
31	Bearing Cone Rear	1	1312100908
32	Bearing Cone Front	1	1312100906
33	Bearing Cap Front	1	1312100907
34	Seal-Shaft	1	1312100911
35	Cap Front	1	1312100868
36	Capscrew-Hex M16x120	1	0147149203
37	Key Fly Wheel C1	1	1312100928
38	Lockwasher 16	1	0333224300
39	Nut - Hex M16	1	0261111403
40	Gasket - Cylinder to Crankcase	1	1312100914

41	Capscrew-Hex M10x30	6	0147136303
42	Copper Gasket 10	6	1312100923
43	Aftercooler	1	1312100875
44	Gasket Valve Cover	3	1312100919
45	Elbow - Street	2	1312100865
46	Valve Assy HP Inlet	1	1312100891
47	Safety Valve 250 psi	1	1312100862
48	Gasket Aftercooler	2	1312100918
49	Elbow Aftercooler	1	1312100873
50	Gasket - Cylinder Head	1	1312100913
51	Capscrew - Skt HD M8x30	2	0211132603
52	Capscrew - Skt HD M8x25	2	0211132503
53	Lockwasher 12	8	0333223600
54	Capscrew-Hex M12x70	8	0147140903
55	Gasket Intercooler	2	1312100927
56	Cover Valve	3	1312100897
57	Safety Valve 75 psi	1	1312100889
58	Capscrew-Hex M8x90	4	0147133803
59	Copper Gasket B8	7	1312100924
60	Intercooler	1	1312100871
61	Aluminum Tube 10x380	1	1312100863
62	Filter Inlet Assembly	1	1312100881
63	Filter Replacement Element	1	FE001
64	Connecting Rod	2	1312100869
65	Dipper-Oil	2	1312100870
66	Insert Half	4	1312100905
67	Bearing- Wrist Pin Needle	2	1312100910
68	Snap Ring - Internal	4	1312100867
69	Wrist Pin LP Piston	1	1312100901
70	Wrist Pin HP Piston	1	1312100902
71	Piston-LP	1	1312100887
72	Piston-HP	1	1312100888
73	Piston Ring Set- LP	1	1312100885
74	Piston Ring Set- HP	1	1312100886
75	Copper Gasket - Valve Seat	5	1312100922
76	Valve Assembly-LP Inlet	2	1312100890
77	Bushing 3/4 x 1 1/4"	1	1312100334
	Gasket Set		1312100925
	Head Rebuild Kit		1312100780
	Overhaul Kit		1312100775

# CA2 (1312202700)

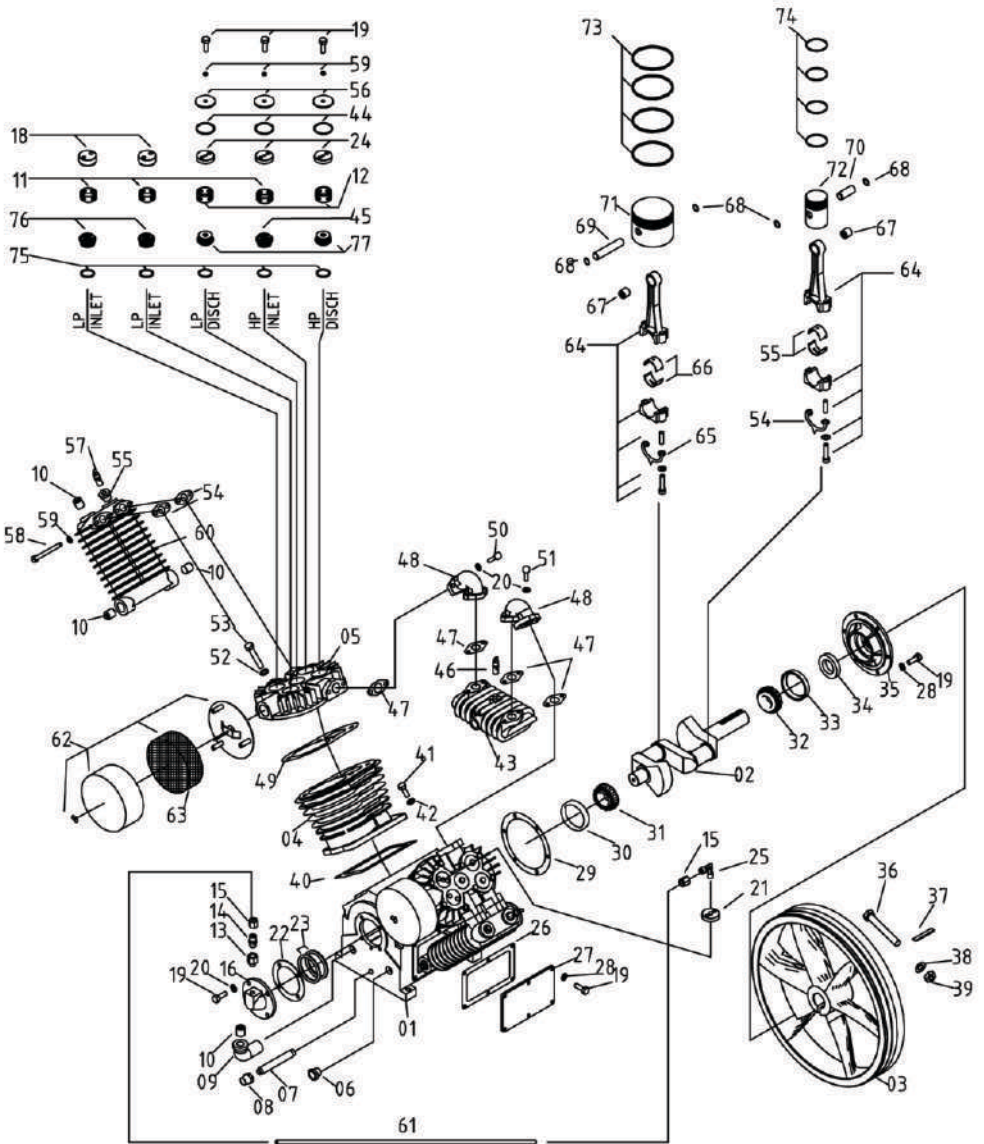

# CA2 (1312202700)

Item	Description	Qty	Part #
1	Crankcase	1	1312100877
2	Crank Shaft	1	1312100931
3	Fly Wheel	1	1312100883
4	Cylinder	1	1312100880
5	Head (Left)	1	1312100878
	Head (Right)	1	1312100879
6	Oil Sight Glass	1	1312100903
7	Oil Drain Pipe	1	1312100859
8	Oil Drain Pipe Cap	1	1312100861
9	Oil Fill Elbow	1	1312100933
10	Plug	4	1312100866
11	Spacer - Inlet Valve	2	1312100893
12	Spacer Discharge Valve	3	1312100894
13	Breather Body	1	1312100934
14	Copper Connector	1	1312100860
15	Copper Nut	2	1312100856
16	Cover-Centrifugal Unloader	1	1312100899
18	Retainer Inlet Valve	4	1312100898
19	Capscrew-Hex M8x25	28	0147132503
20	Lockwasher 8	8	0333222500
21	Retainer Inlet Valve	2	1312100895
22	Gasket Rear Cap	1	1312100920
23.1	Shim 0.20 Brg. Adj.	1	1312100930
23.2	Shim 0.10 Brg. Adj.	2	1312100929
24	Retainer Discharge Valve	4	1312100896
25	Copper Elbow	1	1312100857
26	Gasket Side Cover	2	1312100917
27	Cover Crankcase Side	2	1312100904
28	Copper Gasket	26	1312100921
29	Gasket Front Cap	1	1312100915
30	Bearing Cap Rear	1	1312100909
31	Bearing Cone Rear	1	1312100908
32	Bearing Cone Front	1	1312100906
33	Bearing Cap Front	1	1312100907
34	Seal-Shaft	1	1312100911
35	Cap Front	1	1312100868
36	Capscrew-Hex M16x120	1	0147149203
37	Key Fly Wheel C1	1	1312100928
38	Lockwasher 16	1	0333224300
39	Nut - Hex M16	1	0261111403
40	Gasket - Cylinder to Crankcase	1	1312100914
41	Capscrew-Hex M10x30	12	0147136303
42	Copper Gasket 10	12	1312100923

43	Aftercooler	1	1312100874
44	Gasket Valve Cover	6	1312100919
45	Valve Assy HP Inlet	2	1312100891
46	Safety Valve 250 psi	1	1312100862
47	Gasket Aftercooler	4	1312100918
48	Elbow Aftercooler	2	1312100872
49	Gasket - Cylinder Head	2	1312100913
50	Capscrew - Skt HD M8x30	4	0211132603
51	Capscrew - Skt HD M8x25	4	0211132503
52	Lockwasher 12	16	0333223600
53	Capscrew-Hex M12x70	16	0147140903
54	Gasket Intercooler	4	1312100927
55	Reducing Bushing	2	1312100864
56	Cover Valve	6	1312100897
57	Safety Valve 75 psi	2	1312100889
58	Capscrew-Hex M8x90	8	0147140903
59	Copper Gasket B8	14	1312100924
60	Intercooler	2	1312100871
61	Aluminum Tube 10x380	1	1312100863
62	Filter Inlet Assembly	2	1312100881
63	Filter Replacement Element	2	FE001
64	Connecting Rod	4	1312100869
65	Dipper-Oil	4	1312100870
66	Insert Half	8	1312100905
67	Bearing- Wrist Pin Needle	4	1312100910
68	Snap Ring - Internal	8	1312100867
69	Wrist Pin LP Piston	2	1312100901
70	Wrist Pin HP Piston	2	1312100902
71	Piston-LP	2	1312100887
72	Piston-HP	2	1312100888
73	Piston Ring Set- LP	2	1312100885
74	Piston Ring Set- HP	2	1312100886
75	Copper Gasket - Valve Seat	10	1312100922
76	Valve Assembly-LP Inlet	4	1312100890
77	Valve Assembly HP/LP	4	1312100334
	Gasket Set	1	1312100926
	Head Rebuild Kit		1312100781
	Overhaul Kit		1312100776

Learn more about air compressors we have.