



INS-260-12

## Installation Instructions for Model SL-260 Work Light Replacement

### WARNING: RISK OF ELECTRICAL SHOCK

Unplug the light before replacing the light

Electrical Rating - All models use 125 Volts 60 Hz

**CAUTION** - TO REDUCE THE RISK OF ELECTRIC SHOCK AND FIRE - PULL PLUG WHEN REPLACING THE LED LIGHT HANDLE

#### CAUTION

DO NOT use this cord reel in explosive atmospheres, near flammable liquids, or where explosion proof lamps are required.  
DO NOT use in the proximity of vehicles or equipment when there is a risk of flammable liquids coming into contact with the hand lamp  
DO NOT immerse in water  
DO NOT use in areas where water can accumulate or in rain or mist  
**CAUTION:** Risk of Electric Shock – For Light Duty Dry Location Use Only

**GENERAL USE CORD REEL ONLY. NOT FOR HARD USE. FOR INDOOR DRY LOCATION USE ONLY FOR LIGHT DUTY RESIDENTIAL USE ONLY**

**WARNING: NOT FOR USE ABOVE HAZARDOUS LOCATIONS**  
**CAUTION: DO NOT USE IN HAZARDOUS LOCATIONS AS REQUIRED BY THE CANADIAN ELECTRICAL CODE, PART I**

#### IMPORTANT SAFETY INSTRUCTIONS

This product has a 3 prong polarized plug on the power cord. Do not attempt to bypass this safety feature by removing the round plug and defeat his safety feature. This plug will fit into a grounded outlet only one way. If the plug does not fit fully into the outlet, contact a qualified electrician. Never use with a two wire extension cord.

Thank you for purchasing this Bayco work light. Save these instructions. Please read these instructions before [using your work light](#).



#### OPERATION

To operate, plug into a 120 Volt 60 HZ outlet. The work light has a two position rocker switch to activate the floodlight: or turn it off.

#### SAFETY

**CAUTION BRIGHT LED RADIATION: AVOID DIRECT EYE EXPOSURE.** The light is a Class 2 LED product per IEC 60825-1 Edition 1.2.2001.

#### PRE- ASSEMBLY INFORMATION

##### Tools Required

Wire cutter pliers	Lineman's pliers
Wire Stripper	Small Phillips screwdriver
Electrical connector crimping tool	

##### The SL-260 replacement work light comes with the following items

Two U-shaped metal crimp rings	Flexible strain relief
Two electrical crimp connectors	One magnetic hook
Installation instructions	

If you are missing any of the above materials, contact Bayco to obtain the missing item(s).

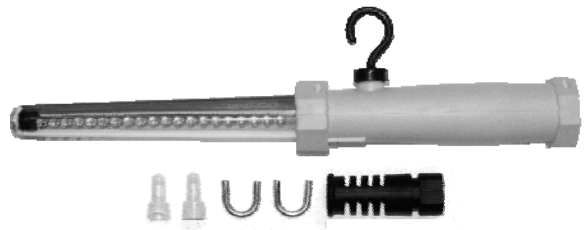

**Crimp connectors**  
Connecteurs à sertir  
Conectores

**U-rings**  
U-anneaux  
U-anillos

**Strain-relief**  
Décharge de traction  
De alivio de tensión

#### WORK LIGHT REPLACEMENT

The SL-260 is a replacement LED work light handle assembly. Unplug the light before replacing the light

##### Prepare the existing cord

- Cut the existing work light off of the cord reel cord.
- Slip the black strain relief over the cord with the wide end facing the end of the wires. Slide it a few inches away from the end of the cord.
- Strip the white and black wires per the drawing. Position the 2 U-shaped clamp rings per the drawing and crimp them tightly with the lineman's pliers. The clip should be tight enough so that it cannot be moved along the cord.

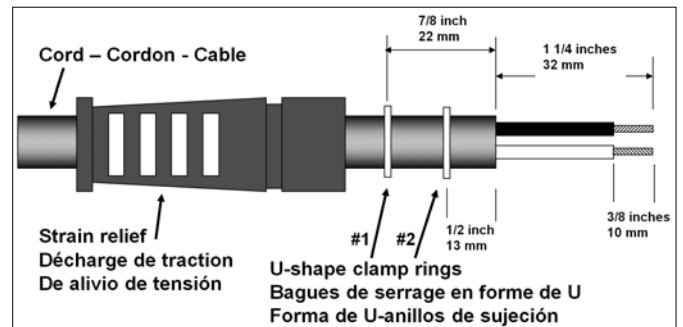

##### Attaching the cord to the handle

- Open the handle by removing 4 screws. Set these aside. Carefully separate the handle halves starting at the switch end. Place the empty handle half on the side. Remove the plastic cord clamp.
- Take the white wire from the work light circuit and the white wire from the cord and twist their copper conductors together. Then, take the electrical crimp connector and slide it over the twisted conductors as far as it will go. Hold this assembly while crimping the connector with an electrical crimping tool. Repeat this step with the black wires. Test for a secure crimp.
- Slide the strain relief up to the base of the light and lay the strain relief into the end of the light. The strain relief only fits properly when the square sides of the strain relief fit easily into the base of the light.
- Locate the #2 U-shape clamp ring inside the plastic cord clamp location. Attach the plastic cord clamp with 2 screws.
- With the cord and wires tucked into the light housing, replace the handle half and secure with 4 screws (see step a)

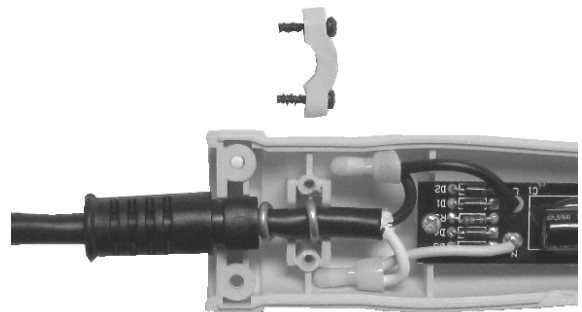
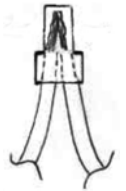

## **WARRANTY**

### **PRODUCTS COVERED UNDER THIS LIMITED WARRANTY:**

This product is warranted to the original purchaser for 1 year and only covers failures due to defects in materials or workmanship. If this product is used for rental purposes, the warranty term is reduced to 90 days from the date of purchase.

### **NOT COVERED**

The warranty does not cover normal wear and tear or cosmetic damage. The Limited Warranty also does not cover damages which occurred in shipment or failures which are caused by accidents, misuse, abuse, faulty installation and lightning damage. Consequential damages, incidental damages or incidental expenses, including damage to property. Some states do not allow the exclusion or limitation of incidental or consequential damages, so the above limitation or exclusion may not apply to you. This warranty gives you specific legal rights, which may vary from state to state. This warranty does not apply to certain Bayco professional products that carry a specific warranty unique to those products.

### **WARRANTY CLAIMS - USA**

Contact Bayco for USA warranty claims. Call and Bayco Customer Service will provide a Return Goods Authorization (RGA) to facilitate rapid warranty action. After receiving the RGA, send the product (shipping prepaid) to BAYCO. Include a dated proof of purchase and a brief description of the defect with your name, address and phone number. Your product will either be repaired or replaced at the option of Bayco and returned as soon as practical, but no later than 45 days after being received by Bayco.

### **WARRANTY CLAIMS - CANADA**

Return the product to the place where purchased with a dated proof of purchase and a brief description of the defect with your name, address and phone number. Your product will either be replaced or purchase price refunded.

### **REQUEST FOR WARRANTY ACTION**

If you have any questions about this warranty or any other Bayco product inquiries contact BAYCO.