



INS-1003-12

500 Watt Halogen Work Light Important safety instructions

**WARNING: Read all instructions carefully
SAVE THESE INSTRUCTIONS
CAUTION: RISK OF ELECTRICAL SHOCK**

- Do not use with extension cord near water or where water may accumulate.
- Keep plugs and receptacles dry.
- For use only on GFCI protected circuits.
- Risk of burns, do not operate without guard. (See assembly instructions.)
- **Lighted lamp is hot.** Keep away from combustibles. Unplug to change bulb. Do not touch bulb

WARNING RISK OF FIRE, ELECTRIC SHOCK, EXPOSURE TO EXCESSIVE UV RADIATION OR INJURY TO PERSONS

- Unit operates on 120V AC 60 Hz only
- Unplug and allow cooling before replacing bulb.
- Bulb gets HOT quickly
- Do not touch hot lens guard or enclosure.
- Do not remain in light if skin feels warm.
- Do not look directly at lighted lamp.
- Keep lamp away from materials that may burn.
- Use only with a 500 Watt or smaller type T bulb.
- Do not touch the bulb at any time; use a soft cloth or gloves. Oil from skin may damage bulb.
- Do not operate the lamp with missing or damaged guard, lamp containment barrier or UV light filter.



SAVE THESE INSTRUCTIONS

WARNING: When using outdoor use work lights, basic safety precautions should always be followed to reduce the risk of fire, electrical shock, and personal injury, including the following:

- Use only three-wire outdoor extension cords that have three-prong grounding plug and receptacles that accept the appliance's plug.
- Ground Fault Circuit Interrupter (GFCI) protection should be provided on the circuit(s) or outlet(s) to be used for the wet location work light. Receptacles are available having built-in GFCI protection and are able to be used for this measure of safety.
- Use only an extension cord for outdoor use, such as an extension cord of cord type SW, SW-A, SOW, SOW -A, STW, STW-A, STOW, STOW-A, SIW, SIW-A, SIOW, SIOW-A, SJTW, SJTW-A, or SJTOW, SJTOW-A.

**BULB INSTALLATION AND REPLACEMENT
DO NOT TOUCH BULB WITH BARE HANDS**

1. Turn the light off and unplug from the power source.
2. Allow the fixture to fully cool before proceeding.
3. Always wear gloves or use a clean cloth to handle bulb. The natural oil from skin will leave a residue that will cause the light to burn out immediately.
4. To remove the lens cover, remove the retaining screw on the back of the lens cover. The lens cover will then swing open exposing the bulb.
5. To remove the bulb, grip one end of the bulb and gently push towards the other end and pull outward to release the bulb.
6. Using a clean cloth or wearing gloves to hold the bulb, gently insert one end of the bulb into the receptacle and press firmly into place. Place the other end of the bulb into the opposite receptacle and gently press into place. Make sure bulb is seated properly.
7. Close the lens cover and replace the retaining screw.
8. Do not test light without lens cover properly attached.

**WARNING: Read all instructions carefully
SAVE THESE INSTRUCTIONS
CAUTION: RISK OF ELECTRICAL SHOCK**

WARRANTY

PRODUCTS COVERED UNDER THIS LIMITED WARRANTY:

This product is warranted to the original purchaser for 1 year and only covers failures due to defects in materials or workmanship. If this product is used for rental purposes, the warranty term is reduced to 90 days from the date of purchase.

NOT COVERED

The warranty does not cover normal wear and tear or cosmetic damage. The Limited Warranty also does not cover damages which occurred in shipment or failures which are caused by accidents, misuse, abuse, faulty installation and lightning damage. Consequential damages, incidental damages or incidental expenses, including damage to property. Some states do not allow the exclusion or limitation of incidental or consequential damages, so the above limitation or exclusion may not apply to you. This warranty gives you specific legal rights, which may vary from state to state. This warranty does not apply to certain Bayco professional products that carry a specific warranty unique to those products.

WARRANTY CLAIMS - USA

Contact Bayco for USA warranty claims. Call and Bayco Customer Service will provide a Return Goods Authorization (RGA) to facilitate rapid warranty action. After receiving the RGA, send the product (shipping prepaid) to BAYCO. Include a dated proof of purchase and a brief description of the defect with your name, address and phone number. Your product will either be repaired or replaced at the option of Bayco and returned as soon as practical, but no later than 45 days after being received by Bayco.

WARRANTY CLAIMS - CANADA

Return the product to the place where purchased with a dated proof of purchase and a brief description of the defect with your name, address and phone number. Your product will either be replaced or purchase price refunded.

REQUEST FOR WARRANTY ACTION

If you have any questions about this warranty or any other Bayco product inquiries contact BAYCO.

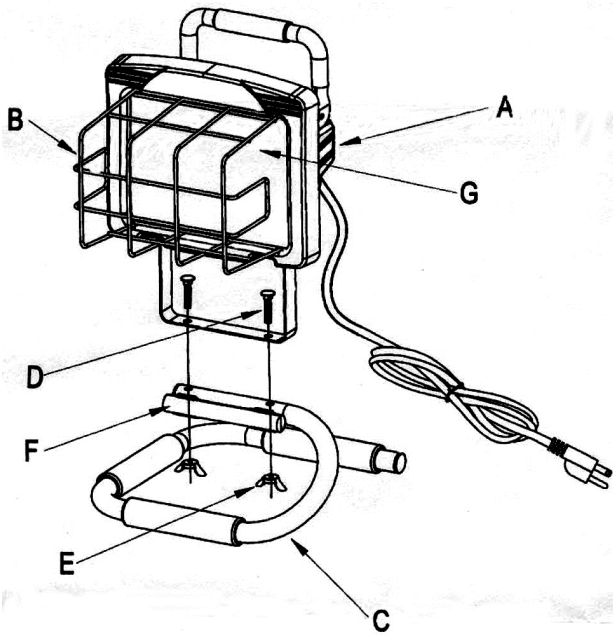

**Model 1003 Assembly Instructions for
Single 500 Watt Halogen Light**

- A - 500 watt halogen light assembly
- B - Grill guard
- C - Stand
- D - Light assembly bolt
- E - Wing nut
- F - Spare bulb holder
- G - Lens

1. Attach halogen light assembly A to stand C using light assembly bolt D and wing nut E
2. Snap grill guard B over the lens on the halogen light assembly A

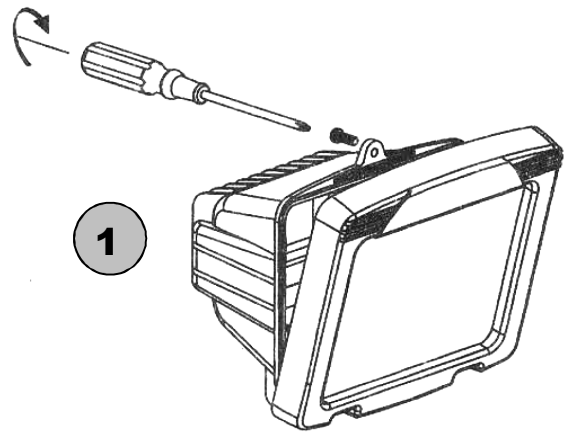

1

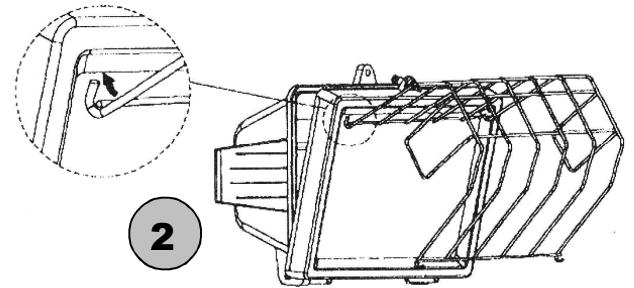

2

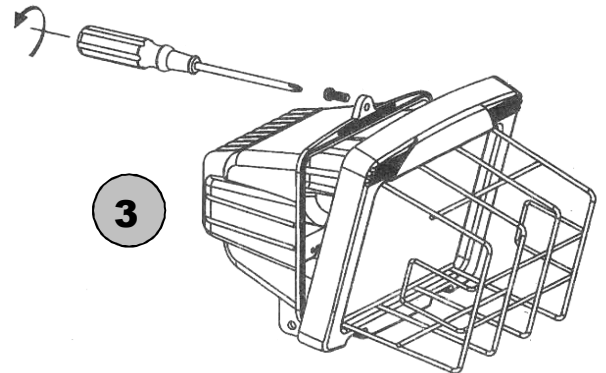

3

BAYCO PRODUCTS LIMITED 1-YEAR WARRANTY

WARRANTY

Bayco Products, Inc. warrants this product to be free from defects in workmanship and materials to the original purchaser for one (1) year from the date of purchase, and includes the LEDs, housing, lenses, electronics, switches, rechargeable batteries and chargers. Bulbs (other than LEDs) are covered for ninety (90) days from the date of purchase. Disposable non-rechargeable batteries are excluded from this warranty. Normal wear and failures which are caused by accidents, misuse, abuse, faulty installation and lightning damage are also excluded.

Consequential damages, incidental damages or incidental expenses, including damage to property are also not covered under this warranty. Some states do not allow the exclusion or limitation of incidental or consequential damages, so the above limitation or exclusion may not apply to you. This warranty gives you specific legal rights, which may vary from state to state.

IN NO EVENT WILL BAYCO PRODUCTS, INC. OR ITS AFFILIATES OR SUPPLIERS BE LIABLE FOR ANY INDIRECT, SPECIAL, INCIDENTAL OR CONSEQUENTIAL DAMAGES OF ANY KIND REGARDLESS OF THE FORM OF ACTION, WHETHER IN CONTRACT, TORT (INCLUDING NEGLIGENCE), STRICT LIABILITY OR OTHERWISE. THE TOTAL CUMULATIVE LIABILITY TO CUSTOMER, FROM ALL CAUSES OF ACTION AND ALL THEORIES OF LIABILITY, WILL BE LIMITED TO AND WILL NOT EXCEED THE PURCHASE PRICE OF THE PRODUCT PAID BY CUSTOMER.

If this product is used for rental purposes, the warranty term is reduced to 90 days from the date of purchase.

WARRANTY CLAIMS – USA

Return the product to the place of purchase for all warranty related issues. If this is not possible, contact Bayco Customer Service for a Return Goods Authorization (RGA). Do not return this product to Bayco without first receiving an RGA Number from Bayco Customer Service. When returning the product, the RGA Number must be written on the outside of the shipping box.

WARRANTY CLAIMS – OUTSIDE OF USA

Return the product to the place where purchased for all warranty related issues.

EXTENT OF COVERED WARRANTY WORK

Bayco will repair or replace this product at our option. If it is determined that the warranty is no longer in effect, Bayco will contact you with a repair estimate before beginning any work.

WARRANTY QUESTIONS

If you have any questions about this warranty or any other Bayco product inquiries, please contact Bayco Customer Service.

**Declaration of Conformity
SL-1003**

The equipment which accompanies this declaration is in conformity with EU Directive(s):
EU Directive 2011/65/EU, concerning the restriction of the use of certain hazardous substances in electrical and electronic equipment (RoHS), as adopted by EU member states on January 2, 2013 (including restrictions on the use of Deca-BDE) ("EU RoHS"). The specifics of this compliance are as follows:

These Products are fully compliant and do not contain the restricted substances above levels noted in EU RoHS.

Including:

- Cadmium (Cd),
- Lead (Pb),
- Mercury (Hg),
- Hexavalent chromium (Cr⁶⁺),
- the following flame retardants:
 - polybrominated biphenyls (PBB)
 - polybrominated diphenyl ethers (PBDE)

Phthalates:

- (DnHP) Di-n-Hexyl Phthalate
- (DnBP) Di-n-Butyl Phthalate
- (BBP) Di-Ethyl Hexyl Phthalate
- (DEHP) Di-n-Octyl Phthalate
- (DINP) Di-Isononyl PHthalate
- (DIDP) Di-Isodecyl Phthalate

Description of Equipment (SL-1003)

This product is a 500w Halogen Single Fixture Work Light.

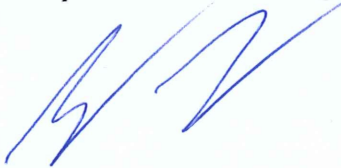

Signature:
Bijan Bayat
President / CEO
11/26/2014