

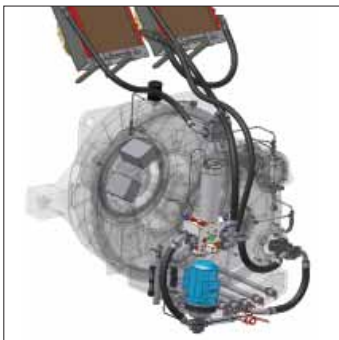

aerospace  
climate control  
electromechanical  
**filtration**  
fluid & gas handling  
hydraulics  
pneumatics  
process control  
sealing & shielding



## Wind Energy

System and Product Solutions  
from Parker Filtration



ENGINEERING YOUR SUCCESS.

# Products and Solutions for the

As the demand and potential for wind energy increases, so does the complexity, size and engineering constraints associated with higher performance, reliability and output demanded from today's generation of wind turbines around the world.

At Parker, we understand the demands facing original equipment manufacturers today for product reliability, innovation and accuracy and through developing effective and affordable system solutions; we aim to provide the answers.

A global presence in the industry makes Parker Filtration an ideal partner for the wind energy industry, providing quality components, service support and added value at every level and at every opportunity.

## System Design



Applying the latest engineering design technologies and CAD software together with more than 50 years experience in filtration and more recently condition and contamination monitoring techniques, Parker engineers are able to work side by side with customers to deliver effective solutions.

Deliverables that incorporate the best technologies combining with space and weight saving solutions that ensure a Parker Filtration design proposal is engineered for your success.

# Wind Energy Market

## System Reliability



As a compliment to its innovative system design and manufacture, Parker Filtration ensures product reliability through the implementation of long established engineering principles.

Quality materials, controlled manufacturing, rigorous testing and evaluation resulting in quality products to be justifiably proud of – all backed by Parker's worldwide service and customer support programme.

## System Performance



'Engineering Your Success' is Parker's way of saying that through striving for product excellence and system performance we aim to be a contributory factor in our customers' success - the best product for the job, delivered on time and delivering the required performance.

Parker systems operate in some of the harshest environments known, providing 'touch of a button' accurate contamination analysis and filtration operation time after time.

## Service and Value



To Parker, adding customer value is as important as adding efficiency and reliability. The opportunity to reduce equipment downtime, extend service life and predict system problems continues to be an engineering and manufacturing focus for Parker Filtration.

Operating in almost every country on every continent, Parker, through its manufacturing locations, Sales Company network, Distributors and Service Centres is geared for fast response with solutions for all your fluid power and filtration requirements.



ENGINEERING YOUR SUCCESS.

# Engineering Success in Renewable Energy

## Integrated Filtration Solutions



Filter Manifold Block

- Manifold design reduces piping, leak points and assembly costs
- 5 and 10 micron filtration
- Low pressure drop
- Magnetic pre-filtration
- Integrated pressure and temperature control valves
- Modular construction to increase capacity



As a leading, global innovator in motion and control, Parker Hannifin provides high-performance components and systems to the wind energy industry. On and offshore, Parker and particularly Parker Filtration is working hard to provide manufactures in this fast expanding industry with cost-effective and efficient hydraulic and lubrication

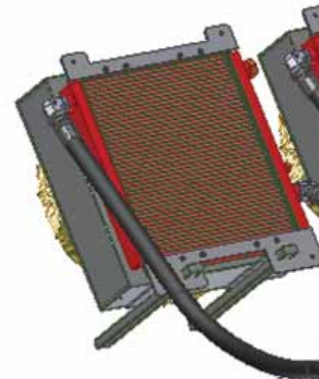

## Cooling Systems

- Critical for heat balance in lube systems
- Oil to air
- Oil to water
- Bypass valves
- Motor speed control
- Mounting brackets

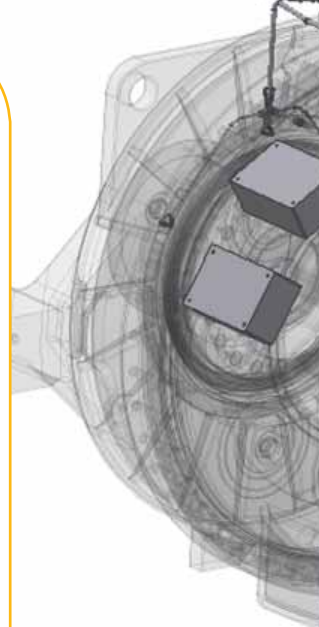
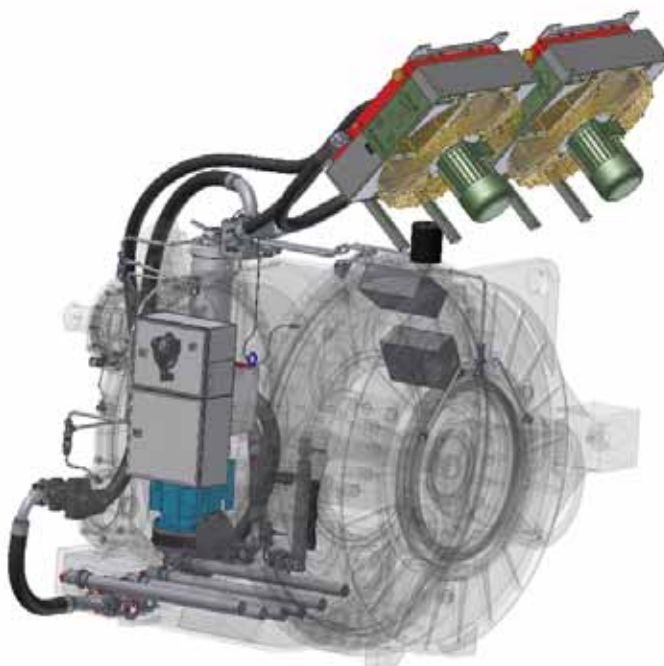
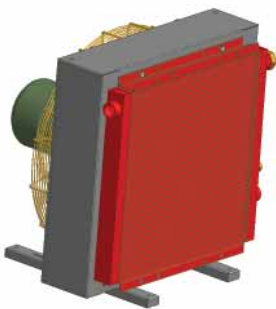



# Energy – Case Study

system solutions and condition monitoring technology. To help explain our 'partnering approach' to development co-operation, we have taken this opportunity to develop a typical partnering application for a wind turbine gearbox application.

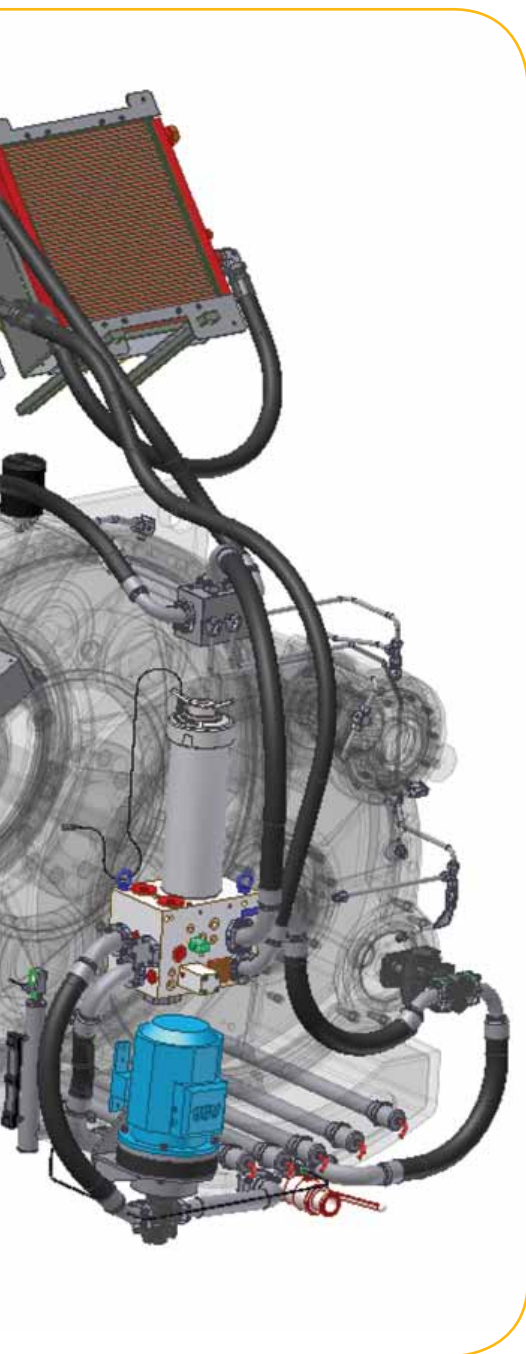

## Condition Monitoring Early Warning

- iCount lubrication and hydraulic oil monitoring system
- Early warning of unwanted changes in oil quality
- Independent monitoring of system contamination
- Continuous performance
- Full PC/PLC integration
- Prolong system life and reduce downtime

## Oil Distribution Blocks

- Customized system blocks
- Simplified installation and servicing
- Pre-assembled and tested
- Provides regulated oil distribution throughout lube oil systems

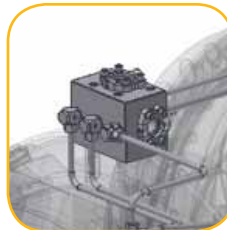

## Lube Oil Tanks and Accessories

- Tanks designed to meet system requirements
- Robust and reliable construction
- Environmental gearbox breathers
- Fluid level gauges
- Cold start heater units
- Moisture Sensors
- Temperature Sensors

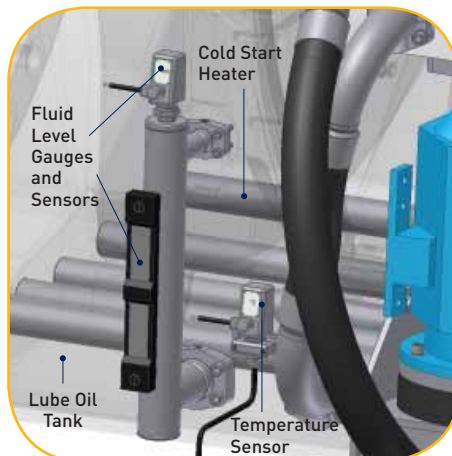

## Pumps and Ball Valves

- A wide range of proven gear pumps and ball valves
- Electrical 2-speed motors as standard. Frequency controlled option available
- Mechanical bi-directional pumps driven by the gearbox
- Cast iron construction

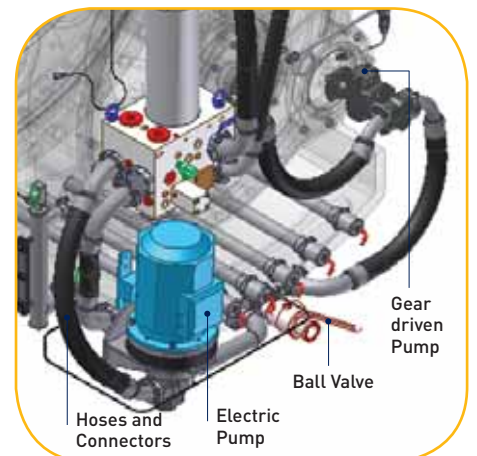

# Hydraulic Filtration and Fluid

At Parker, we are committed to an effective filtration and condition monitoring strategy that will prolong equipment life in wind turbines, while minimising maintenance and downtime costs. As increasing numbers of wind turbines move out of their manufacturers' warranty period, more and more third party maintenance engineers will be required to provide independent advice to wind farm operators. In particular, third party technical capacity will be required for component inspections, repairs and refurbishment, especially for critical parts such as gearboxes and blades.

With hydraulic systems representing a substantial part of each turbine, being used for yaw, pitch and brake control, it is important that operators and prospective maintenance providers are aware of the potential problems that could arise as parts wear, and how to implement an effective predictive maintenance programme.

## Filtration Solutions

Where hydraulic control systems are used, effective filtration technology is especially important, extending maintenance intervals and increasing the reliability of pitch and yaw systems. A comprehensive range of filtration technology has been developed specifically for filtering out particulate and water contamination from hydraulic fluid to just a few microns and PPM of water.



PT Series Low Pressure, Tank Mounted Filters



ABL and EAB, Environmental Air Breathers

## Investing in Technology

Effective filtration technology and hydraulic/lube system cleanliness is essential in the challenge to capture and remove particles before they reach sensitive components in all large capacity turbines. Parker continues to invest in developing products that deliver that technology



EPF (Environmental High Pressure Filter) Series and iProtect® Elements



BGLW Lube filter with optional icountPD Particle Detector and MS Moisture Sensor

# Condition Monitoring Solutions

Parker's global experience in developing the latest generation of hydraulic technology specially developed to meet the specific requirements of a modern wind turbine and proven fluid condition monitoring solutions means we are ideally positioned to meet the industry's drive towards wind turbines that are designed to operate at optimum efficiency, while requiring as little manual intervention as possible.

With global demand for renewable energy on the increase it is essential that turbines function reliably at their full potential so that turbine operators, in partnership with Parker, can ensure that they are meeting the need for wind power while also generating a healthy profit for their business.



## Fluid Condition Monitoring Solutions

The latest generation of compact online detectors, such as Parker's icountPD particle detector, use laser technology to identify particulate contamination and the presence of moisture. Once installed, these devices continuously monitor the cleanliness of hydraulic and lubricating oil, providing warnings of low, medium or high contamination levels through simple onboard LED indicators or via links to remote control systems.



icountPD Particle Detector

The icountPD provides reliable monitoring up to 1000 cSt oil viscosities. Also available as an option is the MS Series moisture sensor that enables the measurement of the oil's relative humidity.

Parker's icountLCM20 and ACM20 represent a proven range of portable particle counters specifically designed for use with diesel fuels in the case of the ACM20 and hydraulic oil

monitoring ideal for predictive maintenance programmes with the icountLCM20.

The icountPD OCI is an Oil Cleanliness Indicator. Portable and robust, it's a particle detector with an on-board pump and motor with features that include an embedded memory as standard with + 250,000 test capability and a 'self-generating' web server for lap-top interaction.

Parker's range of PVS, portable purification units reduce the catastrophic results of water contamination in oil by 'drawing' the water contaminated fluid out of the system.



icountPD OCI (Oil Cleanliness Indicator)



icountLCM20 and ACM20. Oil and Fuel Portable Particle Analysers and MS Moisture Sensors



PVS Range of Portable Purification Units



# Dedicated products and solutions

## Parker – An Experienced Partner in Wind Energy

Parker has dedicated teams of wind turbine specialists working globally to assist our customers in the design of systems, sub-systems and solutions to meet the most demanding requirements, offering unbeatable global product availability and service.



### Electromechanical Blade Pitch Control Systems

Parker's electro mechanical solutions, include DC drives, brushless servo motor, multi axis motion controllers, servo drives and electric cylinders.



### Power Units

Parker supplies the power necessary to operate pitch, yaw and braking systems and provide backup in case of power failure, ensuring a safe stop with no risk of damage.



### Store Energy

Our complete range of CE approved piston, bladder and diaphragm accumulators maintains high pressure for safe braking and dynamic control. Greater system efficiency and reduced pump sizes gives long life, lower costs and reduced noise levels.



### Integrating real-time intelligence in the gearbox filtration system

Parker's engineered filtration solutions for wind turbines have proven to be effective in positively influencing the life of critical components such as gear boxes and bearings. Special designed filter elements extend the life of the filters and reduce the number of filter changes.



### Steel and Stainless Steel Quick Couplings

A complete range of quick couplings for any tough environment application.

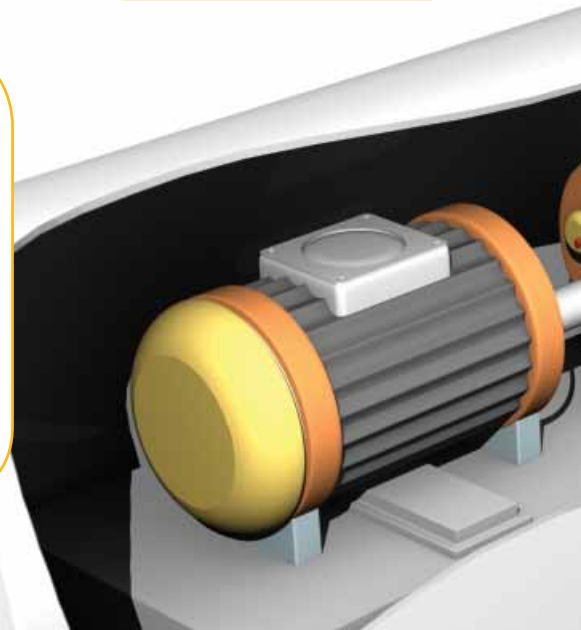



# from Parker

## Parker advantages in short:

- Global presence with over 12,000 service locations
- Outstanding wind turbine experience
- Dry Technology TM
- Complete solutions for motion and control in turbines
- Complete solutions for Power Conversion, transfer and storage
- Time-saving kitting and pre-assembly
- Product availability
- Extended warranty

## Thermoplastic Hoses

Available as single hoses, multiple hoses, hose bundles or preformed hoses, offering superb durability, ozone and UV resistance, non-conductivity, excellent chemical resistance, low volumetric expansion and low pressure drop.

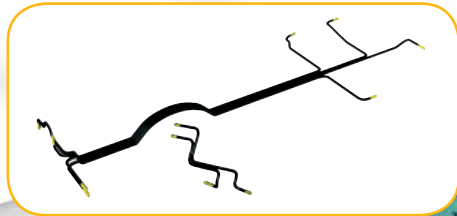

## Pitch Systems

Dynamic pitch systems with specially designed cylinders, with fully protected internal transducers on which integrated blocks containing all necessary valves are mounted, are placed inside the hubs. Parker can supply integrated systems with every component needed, including high performance electronic control valves compatible with any modern wind turbine control system.

## Seal Solutions

A complete range of high quality seals manufactured to International Standards for any tough environment application



## Unique Parflange® Technology

With the new Parflange® F37 system you are signalling the future: from now on, non-welded tube connections for the largest tube dimensions and pressures up to 420 bar (6,000 psi) can be prepared quickly cleanly and with reduced costs. Traditional welding is a thing of the past.



## Hydraulic Fittings

High pressure fittings offering safety, corrosion resistance, leak-free connections and ease of assembly.



## Integrated Functionality

Customized system blocks simplify installation and servicing. These can include threaded cartridges, manifold mounted valves and, in addition, servo proportional valves. Pre-assembled and tested, they offer great value in reducing assembly and installation costs. Save on aftermarket purchasing and servicing!

# Dedicated products and solutions

## Braking Systems

Parker offers a complete range of brake solutions for the wind turbine. Parker's high speed shaft brake solutions are modular – capable of hydraulic or electromechanical actuation, serviceable and adjustable without the need for dis-assembly from the turbine and come complete with the actuation mechanism of your choice. The yaw brakes are self aligning thus increasing the life of the brake and brake liners as well as the slew ring which in turn save thousands of dollars over the turbine life.



## Measuring Devices

A broad range of sensors and adaptors is available in our SensorControl® product offering, all designed to meet global standards. A wide variety of mounting styles, pressure ranges and monitoring systems accommodates all types of application demands. Combined pressure and temperature sensor units are available.



## Specially Designed Cylinders

Parker's hydraulic cylinders for wind turbine applications deliver reliable performance under tough operating conditions. Typically, cylinders incorporate a manifold with control valves and feature a built-in position sensor.

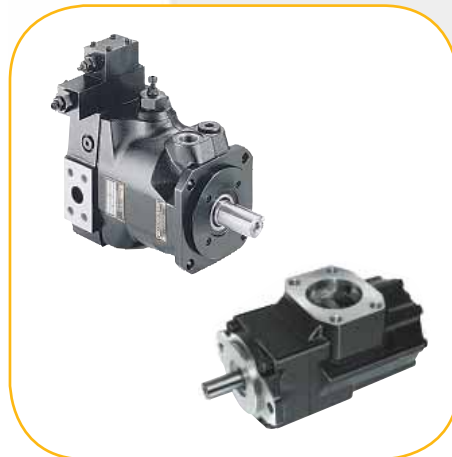

## Quiet Power

Parker offers a range of pumps, from variable piston pumps to fixed displacement vane pumps with high pressure and high speed capacities, low weight and exceptionally low levels of noise.

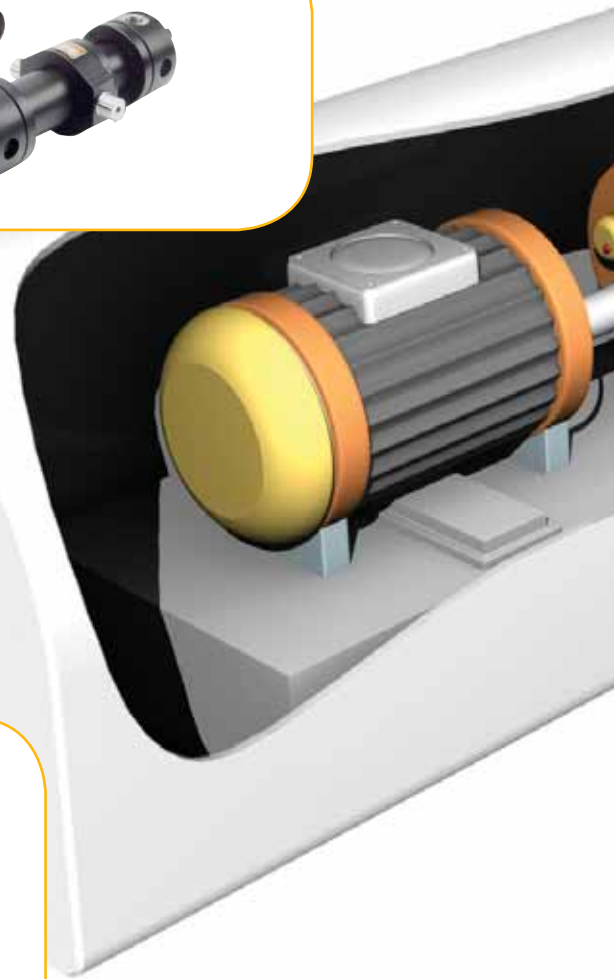

# from Parker

## Subsea Power Cables

Parker Scanrope is a global supplier of Subsea power cables and associated termination equipment to the offshore wind turbine and wave power industry.



## Parker Hoses

The most comprehensive line of hoses and all the fittings and options you'll need, including UV resistance, maximum flexibility, a wide range of media compatibility, and hoses that are made to meet or exceed ISO and EN specifications.



## Racor ECO SE Air Cleaner

Specified for installation on the electrical cabinet of wind turbines to control the inlet air where previously cooling air and dust was able to infiltrate the cabinet through leakage in doors and screw holes.

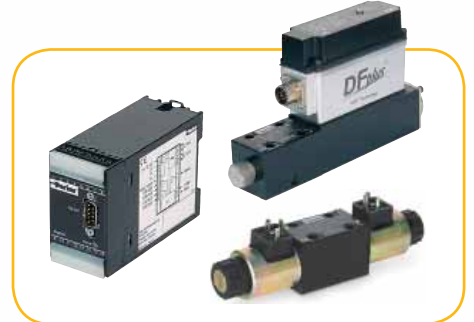

## Precision Hydraulic Valves and Electronics

Proportional valves for accurate and smooth control, high response valves for closed loop applications.

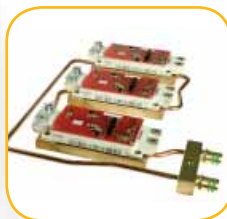

## High Density Electronic Cooling

High performance extreme cooling systems designed into a lightweight, compact system. Advanced Parker Vaporizable Dielectric Fluid cooling technology a 1000 times more effective than air at heat removal with no condensation.

## Grid-Tie Inverter Systems

Parker SSD Drives provides grid-tie inverter systems using innovative filtering and cooling methods to maximise energy recovery and ensure quality power to the grid.



# Parker Interchange Element Range

## PARFIT™

### The one-stop-shop for all your hydraulic filter element requirements

Available immediately and at competitive prices and equivalent or better quality, Parfit interchange elements allow users to acquire all their replacement elements from one quality, single source: regardless of the original equipment specification.

### Together, we can provide over 50,000 quality interchange elements.

The Parker Parfit range offers end users, maintenance engineers and manufacturers a range of over 50,000 quality interchange elements using Microglass III and Ecoglass III media reducing stockholding, cutting costs and ensuring reliable and quality filter performance.

PARFIT elements are manufactured to the same exacting standards as Parker original elements.

#### Features include:

- Manufacturing quality backed by Parker's unrivalled technical resources.
- Reduced stockholding and costs by sourcing all your replacement elements from Parker.
- Interchange elements for Pall, Hydac, Mahle, Internormen, MP Filtri, Donaldson and over 300 other manufacturers.
- Cross reference information available for over 50,000 part numbers.

#### Typical applications include:

- Wind turbines.
- Industrial power units.
- Mobile construction equipment.
- Forestry equipment.
- Marine power plants.
- Agricultural equipment.
- Lorry mounted cranes.
- Waste management trucks.
- Wheeled loaders.

### There's only one solution

When it comes to replacement hydraulic and marine filter elements there is only one solution:

The Parfit interchangeable range. With over 50,000 stocked, off the shelf variations, there's a Parfit element to fit most sizes and makes of filters on mobile, construction, agricultural and industrial plant.



Every Parfit element is manufactured in Europe to the highest standards and is backed by our unrivalled technical support and money back guarantees. That means that you can reduce stockholdings, cut costs and be sure of the ultimate performance, with long, trouble free operating life. Parfit filters are available from ParkerStores and authorized distributors throughout Europe.



# Research and Development

## **We invest in our customers' future**

Development programmes and on-going product improvements are vital for a range that meets market demands for quality, reliability and engineering excellence. We have built a reputation for providing customers with products that ensure that their systems are also up to the highest standards.

## **Scientific research is the foundation for new development.**

R & D resources at the Parker Filtration global manufacturing locations are both complementary and comprehensive, including as examples – Multipass test installations, fatigue test units and cleanliness service (water detection, spectral analysis, particle counting and analysis), 3D ProEngineer and AutoCAD work stations, thermal cycle test chambers, salt spray and humidity chambers.



# Together, we can supply quality Filtration Solutions

Parker Filtration's global reputation as an innovator and manufacturer of reliable, quality filtration solutions is the result of a focused and integrated product development and manufacturing system in addition to many years experience and expertise.

Parker Filtration combines quality filtration products, manufactured by process filtration, air and gas filtration and separation, fuel condition and filtration, hydraulic and lubrication filtration, fluid power products and fluid condition monitoring equipment into one broad-based range that covers many industries and most applications, some of these products are featured here:

## Hydraulic and Lube Filtration and Fluid Condition Monitoring



### icountBS Fluid Quality Bottle Sampler

- Quick sample bottle analysis with variable test time options from 15 seconds and volume capacities from 10ml.
- Repeatable and re-producible result performance to ISO4406:1999 and NAS1638 particle count distributions.



### DF40 Series Duplex in-line filters

- Utilizes a cast iron and steel design. Ideal for marine engine rooms
- Max. pressure 40 bar. Max flow 200 l/min.
- Suitable for fuel, lube and hydraulic fluid systems.



### 10MFP Portable Filtration Trolley

- 10MFP hydraulic trolley is the ideal way to pre-filter & transfer fluids into reservoirs or to clean up a system.
- Maximum flow 38 l/min.
- Par-Gel™ water removal elements available.
- icountPD particle detector option.

## Racor Filtration Solutions



### Racor Fuel Filtration System Solutions

- Racor fuel delivery systems that meet the current and future rigorous diesel emission requirements while protecting vehicle injection systems. Quality products from the leader in fuel filtration.



### Racor Bespoke OEM Solutions

- Integrated fuel delivery systems that continue to forge long term relationships with Global OEM companies to produce sound, cost effective engineered solutions to meet specific application requirements.



### Racor Engine Air Solutions

- Heavy duty air cleaners and pre-cleaners, crankcase ventilation, marine filter/silencers, cabin air filters and replacement filters. High efficiency, application specific media that improves performance as it extends service life.



### Racor Hydrocarbon solutions

- Racor aviation fuel filtration systems are used by customers worldwide to assure the delivery of clean, dry fuel. Filter vessels for refineries, pipelines, bulk storage terminals and airport refuelling equipment.



### Racor Village Marine - Water desalination and purification systems

- Over 30 years manufacturing Reverse Osmosis equipment.
- Meeting fresh water requirements in many industries and applications.
- Built to the highest standards of safety and reliability.

## Parker Dornick Hunter



### High Efficiency Compressed Air Purification

- A complete range of high efficiency OIL-X EVOLUTION filters and PNEUDRII dryers from a single source to remove all compressed air contamination.



### Nitrogen Generators for industrial applications

- Parker nitrogen gas generators produce nitrogen gas from compressed air and offer a cost-effective, reliable and safe alternative to traditional nitrogen gas supplies such as cylinder or liquid.

## Parker Zander



### Drying Technology - The WV Modular Concept

- High-end adsorption by means of vacuum regeneration.
- Savings of 25% are possible compared to conventional systems.
- Active heating under vacuum with ambient air.

## Parker Hiross



### Hyperchill Cooling Solutions

- Parker Hiross' range of Hyperchill water chillers are ideal for water or antifreeze fluid cooling in a closed circuit by means of a refrigeration cycle. They feature superior reliability, high energy efficiency and accurate temperature control of the chilled fluid.



# Parker's Motion & Control Technologies

At Parker, we're guided by a relentless drive to help our customers become more productive and achieve higher levels of profitability by engineering the best systems for their requirements. It means looking at customer applications from many angles to find new ways to create value. Whatever the motion and control technology need, Parker has the experience, breadth of product and global reach to consistently deliver. No company knows more about motion and control technology than Parker.



## Aerospace

### Key Markets

- Aircraft engines
- Business & general aviation
- Commercial transports
- Land-based weapons systems
- Military aircraft
- Missiles & launch vehicles
- Regional transports
- Unmanned aerial vehicles

### Key Products

- Flight control systems & components
- Fluid conveyance systems
- Fluid metering delivery & atomization devices
- Fuel systems & components
- Hydraulic systems & components
- Inert nitrogen generating systems
- Pneumatic systems & components
- Wheels & brakes



## Climate Control

### Key Markets

- Agriculture
- Air conditioning
- Food, beverage & dairy
- Life sciences & medical
- Precision cooling
- Processing
- Transportation

### Key Products

- CO<sub>2</sub> controls
- Electronic controllers
- Filter driers
- Hand shut-off valves
- Hose & fittings
- Pressure regulating valves
- Refrigerant distributors
- Safety relief valves
- Solenoid valves
- Thermostatic expansion valves



## Filtration

### Key Markets

- Food & beverage
- Industrial machinery
- Life sciences
- Marine
- Mobile equipment
- Oil & gas
- Power generation
- Process
- Transportation

### Key Products

- Analytical gas generators
- Compressed air & gas filters
- Condition monitoring
- Engine air, fuel & oil filtration & systems
- Hydraulic, lubrication & coolant filters
- Process, chemical, water & microfiltration filters
- Nitrogen, hydrogen & zero air generators



## Fluid & Gas Handling

### Key Markets

- Aerospace
- Agriculture
- Bulk chemical handling
- Construction machinery
- Food & beverage
- Fuel & gas delivery
- Industrial machinery
- Mobile
- Oil & gas
- Transportation
- Welding

### Key Products

- Brass fittings & valves
- Diagnostic equipment
- Fluid conveyance systems
- Industrial hose
- PTFE & PFA hose, tubing & plastic fittings
- Rubber & thermoplastic hose & couplings
- Tube fittings & adapters
- Quick disconnects

## Hydraulics

### Key Markets

- Aerospace
- Aerial lift
- Agriculture
- Construction machinery
- Forestry
- Industrial machinery
- Mining
- UOil & gas
- Power generation & energy
- Truck hydraulics

### Key Products

- Diagnostic equipment
- Hydraulic cylinders & accumulators
- Hydraulic motors & pumps
- Hydraulic systems
- Hydraulic valves & controls
- Power take-offs
- Rubber & thermoplastic hose & couplings
- Tube fittings & adapters
- Quick disconnects



## Pneumatics

### Key Markets

- Aerospace
- Conveyor & material handling
- Factory automation
- Food & beverage
- Life science & medical
- Machine tools
- Packaging machinery
- Transportation & automotive

### Key Products

- Air preparation
- Compact cylinders
- Field bus valve systems
- Grippers
- Guided cylinders
- Manifolds
- Miniature fluidics
- Pneumatic accessories
- Pneumatic actuators & grippers
- Pneumatic valves & controls
- Rodless cylinders
- Rotary actuators
- Tie rod cylinders
- Vacuum generators, cups & sensors

## Sealing & Shielding

### Key Markets

- Aerospace
- Chemical processing
- Consumer
- Energy, oil & gas
- Fluid power
- General industrial
- Information technology
- Life sciences
- Military
- Semiconductor
- Telecommunications
- Transportation

### Key Products

- Dynamic seals
- Elastomeric o-rings
- EMI shielding
- Extruded & precision-cut, fabricated elastomeric seals
- Homogeneous & inserted elastomeric shapes
- High temperature metal seals
- Metal & plastic retained composite seals
- Thermal management



## Process Control

### Key Markets

- Chemical & refining
- Food, beverage & dairy
- Medical & dental
- Microelectronics
- Oil & gas
- Power generation

### Key Products

- Analytical sample conditioning products & systems
- Fluoropolymer chemical delivery fittings, valves & pumps
- High purity gas delivery fittings, valves & regulators
- Instrumentation fittings, valves & regulators
- Medium pressure fittings & valves
- Process control manifolds

## Electromechanical

### Key Markets

- Aerospace
- Factory automation
- Food & beverage
- Life science & medical
- Machine tools
- Packaging machinery
- Paper machinery
- Plastics machinery & converting
- Primary metals
- Semiconductor & electronics
- Textile
- Wire & cable

### Key Products

- AC/DC drives & systems
- Electric actuators
- Controllers
- Gantry robots
- Gearheads
- Human machine interfaces
- Industrial PCs
- Inverters
- Linear motors, slides & stages
- Precision stages
- Stepper motors
- Servo motors, drives & controls
- Structural extrusions