

# **ES-11 Premium Stand**



## **Assembly Instructions**

The ES-11 Stand is designed to hold securely the equipment shipped with your order. If you have purchased this stand for equipment not designed for mounting to the shelf you will have to secure it by some other means.

*Auto Meter Products Inc.*



- |                               |          |                     |
|-------------------------------|----------|---------------------|
| <b>Tools Needed:</b>          |          |                     |
| • No. 2 Phillips screw driver | • Hammer | • Adjustable wrench |

## 1 Check Contents

Assembly pieces include the following:

### A. 10" Wheel kit:

- 1 - axle
- 2 - wheels
- 2 - wheel caps
- 2 - wheel washers
- 4 - 2 1/2" long bolts with nuts for mounting side brackets
- 4 - 2" hex head bolts with nuts for mounting back side brackets
- 2 - 3/4" long bolts to secure equipment

### B. 4" Caster kit:

- 2 - casters
- 2 - bushings
- 2 sets - 1/2-13 nuts, lock washers and flat washers

### C. Hook kit:

- 1 hook with adhesive pad
- 1 self tapping screw

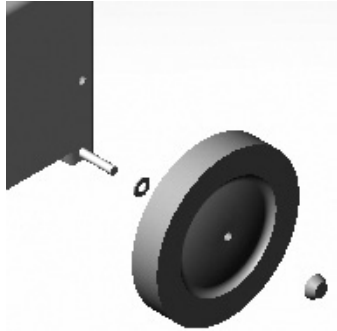

## 2 Wheel Assembly

- Install axle through drilled holes. (A soft hammer will help installing the axle through the drilled holes).
- Slide one wheel washer on each end of the axle.
- Slide one wheel over each end of the axle followed by the wheel cap.
- Place wheel cap squarely and tap with a hammer until seated.

## 3 Casters Assembly

- Align the 2 holes with 2 thread shafts on the bottom 2 holes in the stand.
- Insert the thread shaft as illustrated and attach the flat and lock washer nuts.
- Tighten with wrench until secure.

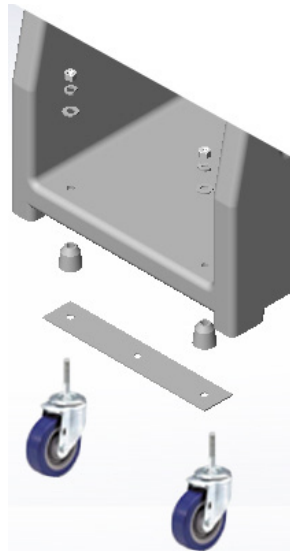

## 4 Bracket Assembly On Left & Back Sides

### A. Left side brackets:

- Align the 2 holes in the bracket with the top 2 holes in the left side of stand.
- Insert 2 1/2" long **PHILLIPS HEAD** screws as illustrated and attach nuts.
- Tighten with a #2 Phillips screw driver and wrench until secure.
- Repeat procedure for the left bottom 2 hole locations.

### B. Back side brackets:

- Align the 2 holes in the bracket with the 2 holes in the back side of stand.
- Insert 2" long **HEX HEAD** bolts as illustrated and attach nuts.
- Tighten with wrenches until secure.
- Repeat procedure for another 2 hole location.

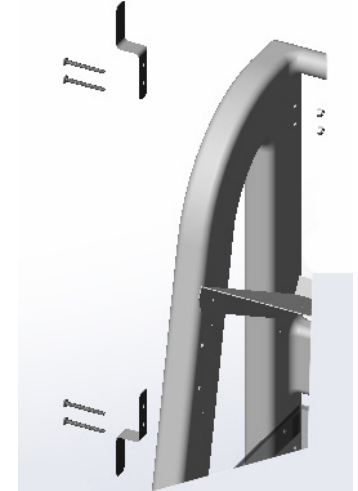

## 5 Hook Assembly

- Peel off the paper of the stick pad on the hook and align the hole in the bracket with the top hole in the right side of the stand.
- Keep the hook horizontal when sticking the pad.
- Insert self tapping Phillips head screw as illustrated.
- Tighten with a #2 Phillips screw driver until secure.

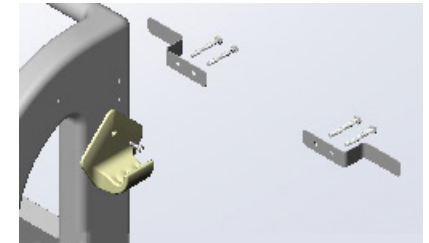

## 6 Mounting the Equipment to the Stand

- Your equipment should have two internal mounting (1/4-20) threaded nuts located on the bottom of the unit. If your equipment does not have internal mounting nuts you will have to secure the equipment by some other means.
- Use the space displaced by the rubber feet, align the 3/4" long bolts with the equipment mounting nuts.
- Tighten with a wrench. Do not over tighten as this will cause the shelf to deform.

