



IS-5700S-S50  
01/05

## ECONOMATIC DRAIN INSTRUCTION SHEET ATD-7815 & ATD-7816

READ CAREFULLY BEFORE ATTEMPTING TO INSTALL, OPERATE OR MAINTAIN ECONOMATIC DRAIN, PROTECT YOURSELF AND OTHERS BY OBSERVING ALL SAFETY INFORMATION. FAILURE TO DO SO COULD RESULT IN PERSONAL INJURY AND/OR PROPERTY DAMAGE! KEEP INSTRUCTION SHEET FOR FUTURE REFERENCE.

### SPECIFICATIONS

Adjustable Cycle Time .....1-60 Minutes  
Adjustable Drain Time .....1-30 Seconds  
Max. Working Pressure .....200 PSIG  
Max. Fluid Temperature .....165°F  
Ambient Temperature .....35°F to 165°F  
Enclosure .....NEMA 1  
Voltage .....115V, 1 Phase, 60 HZ  
Amps .....0.25  
Seals .....Buna-N  
Power Plug .....6 ft. Heavy Duty Grounded

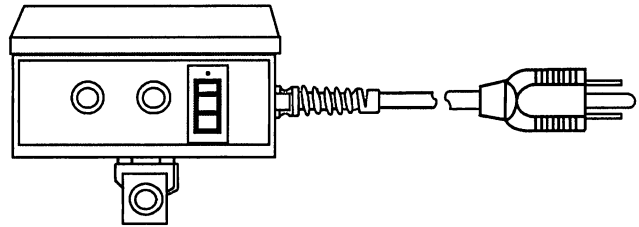

**WARNING!** Do not apply electrical power to the drain unless the unit is fully assembled. Failure to do so could result in personal injury or damage to unit.

**INSTALLATION:** Take care to insure that pipe dope, pipe tape, scale or metal chips are trapped before the solenoid valve seat. Install the Y-strainer (S202 or S204) upstream of the ECONOMATIC drain to trap large debris and sludge, and to extend the life of the ECONOMATIC drain. The ECONOMATIC drain must be installed with the direction of flow (as indicated on the solenoid valve) to atmosphere. The solenoid piping should be pitched downhill. In cases where the normal installation of the ECONOMATIC drain is not possible, it may be piped to a higher discharge point provided that: (a) a trap test port is provided to check for plugging, and (b) the blow down cycle is adjusted to account for increased volume.

**OPERATIONS:** The ECONOMATIC drain may be operated by simply connecting the provided electrical power and adjusting the desired time cycle of 1 to 60 minutes and the open drain cycle of 1 to 30 seconds. **Operation of the drain should only take place when using compressed air. When the compressor is shut down, the ECONOMATIC drain should also be disconnected. Failure to do so could lead to solenoid burn out or premature life failure.** The ECONOMATIC drain is equipped with a manual override switch to check drain performance or excessive water accumulation, do not use as a blow down for the compressed air system. The switch indicator light will be on when the solenoid valve is in the open position during automatic or manual operation.

**When the drain is disconnected from its power source the solenoid valve will remain closed.**

**MAINTENANCE:** Your ECONOMATIC drain will give you years of service if the drain is properly maintained on a regular basis. It is recommended that the maintenance be done monthly. Operating conditions will have to be taken into consideration and the schedule adjusted accordingly.

1. Depressurize the pneumatic system.
2. Disconnect the electrical supply to the ECONOMATIC drain.
3. Remove the drain and flush the solenoid inlet and outlet ports with a safe oil cutting detergent such as Lestoil or Fantastic and water. Make sure water is kept away from all wiring and the ECONOMATIC drain box to prevent damage to the electrical components.
4. Replace the drain in the system and reconnect the power.

## SOLENOID DISASSEMBLY

If the drain is bleeding air, it may be necessary to disassemble the drain solenoid completely. Remove it from the system to clear the seat of foreign materials.

### TOOLS NEEDED

1. Small slot screwdriver.
2. Adjustable crescent wrench.
3. #2 Phillips screwdriver (ATD-7816 only).

### INSTRUCTIONS:

1. Be sure the electrical is disconnected.
2. Remove the cover of the ECONOMATIC drain assembly.
3. Remove the nut which retains the solenoid to the coil and remove the solenoid valve. Observe the direction indicated on the solenoid so that it can be reassembled in the same direction.

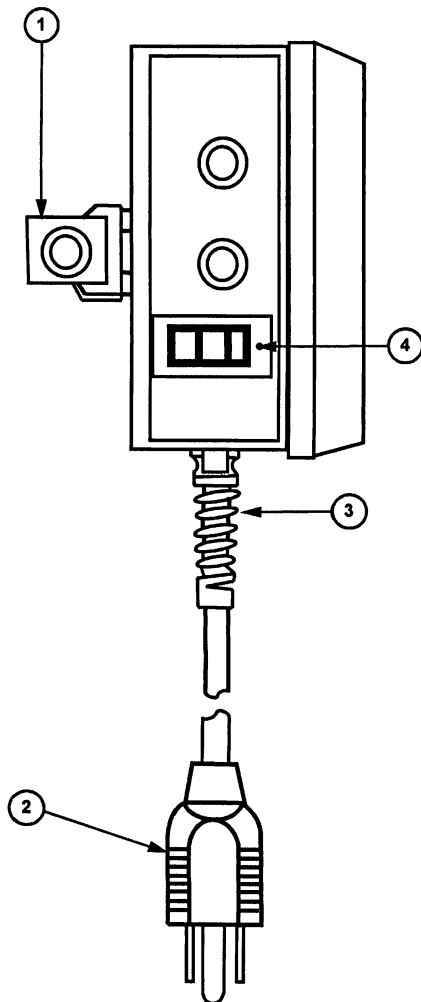

4. Remove the stem assembly.

ATD-7815 Carefully unthread the stem assembly of the solenoid (CCW)

ATD-7816 Remove the 4 Phillips head screw which retain the solenoid actuator.

DO NOT STRIKE OR TWIST THE STEM WITH ANY OBJECT. DOING SO MAY DAMAGE THE ASSEMBLY.

5. Inspect the valve seat and remove any foreign material.
6. Inspect the diaphragm or plunger assembly and remove any foreign material. IF IT IS NECESSARY TO USE A SOLVENT, IT MAY BE USED ONLY ON METAL SURFACES.
7. Reassemble the solenoid and valve reversing the above procedures. On the ATD-7816, be sure the diaphragm and spring are aligned correctly. Be sure that the actuator cover is carefully aligned over the pin and the additional outer cast portion is positioned on the outer side of the solenoid.
8. Reinstall the solenoid into the housing, be sure the inlet and outlet are positioned correctly for the flow.

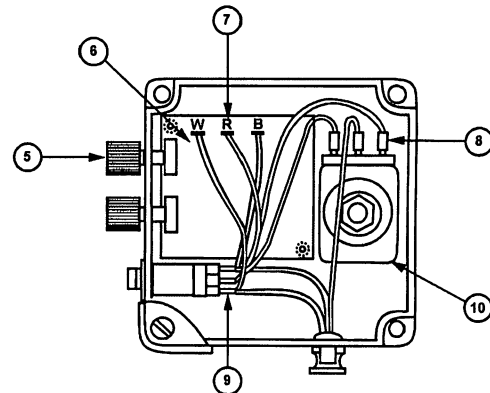

Item	Kit Description	Kit Part Number	Contents
		ATD-5716	
		ATD-5716	
1, 8, 9, 10	Solenoid Valve Kit	VK5702	1/4 Solenoid Valve w/coil, Flag Disconnects, Female Disconnects
		VK5704	1/2 Solenoid Valve w/coil, Flag Disconnects, Female Disconnects
5, 6, 7, 9	Timer Board Kit	TK5700	Timer Board, Knobs, Screws Female Disconnects
4 and 9	Switch Kit	SK5700	Lighted Switch, Female Disconnects
2, 3, 8, 9	Power Cord Kit	PK5700	Power Cord, Cable Restraint, Flag Disconnects, Female Disconnects
11	Y-Strainer	S202-S50	1/4" Y-Strainer
		S204-S50	1/2" Y-Strainer
Not Shown	Y-Strainer Screen	SSK202	Replacement Screen for S202 and S204 Y-Strainers