

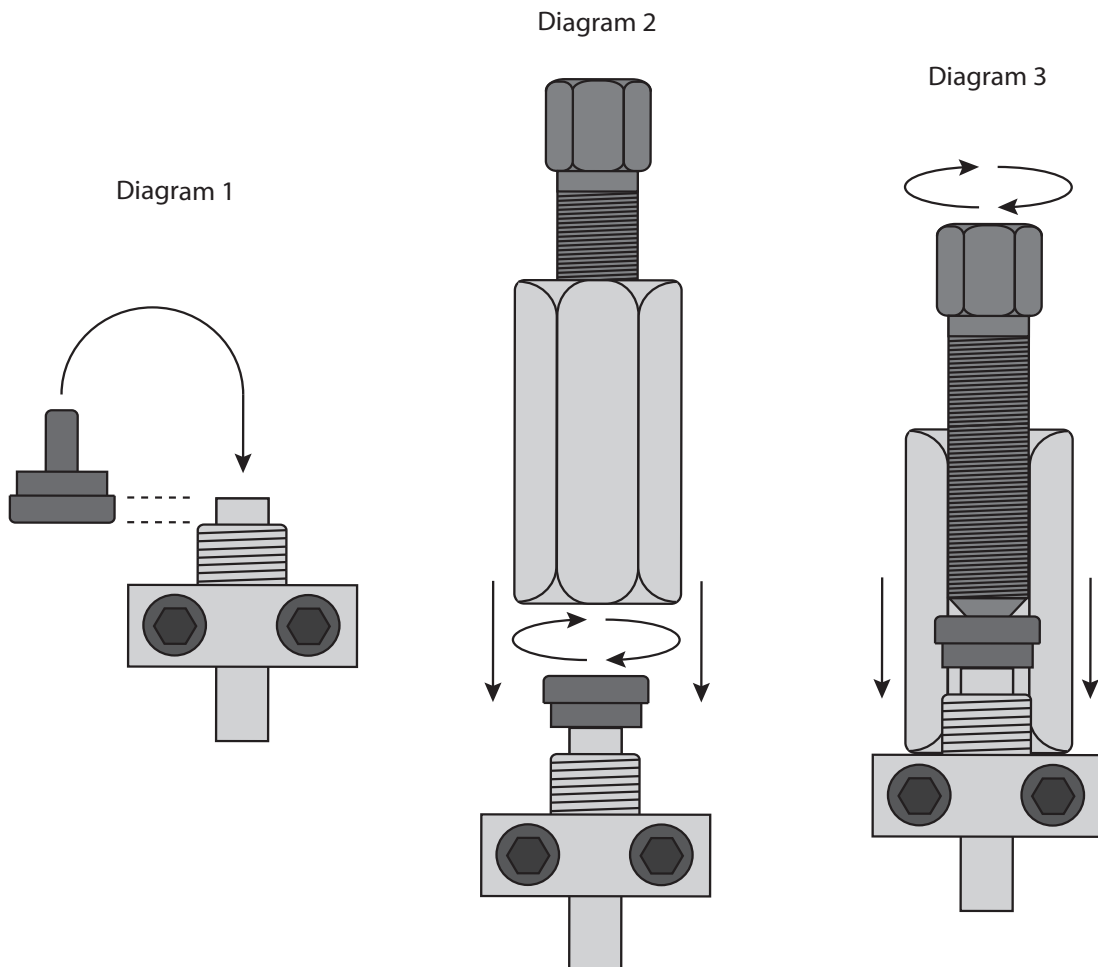

ATD-5481

INSTRUCTIONS FOR IN LINE FLARING

- Make sure tubing is cut off square and burrs removed.
- Chamfer outside of tubing with either a file or grinding wheel.
- Insert tubing through two sides of clamping base using included adapter as guide for proper length.
- Alternate tightening the two cap screws of the clamping base to grip the tubing. Too loose a grip will allow the tubing to push through.
- Insert stem of adapter into end of tubing. (See Diagram 1) Place hex yoke over flaring adapter and hand tighten on to clamping base. (Do not use wrench to tighten) (See Diagram 2)
- Thread flaring screw into Hex yoke. Screw until tight and firm which will produce the first flare. This will form a bell shape in tubing. (See Diagram 3)
- Unthread screw until loose.
- Unthread Hex yoke completely and remove adapter. Check for proper bell shape.
- Replace Hex yoke and tighten to base.
- Thread screw into hex yoke again until completely tight. This should complete the double flare.





PARTS LIST

ATD5481 - SAE In Line Flaring Tool

