



AIR OPERATED OIL/ FLUID PUMP ASSEMBLY

**3:1 RATIO, OUTPUT – 5 GPM.
MIN. AIR PRESSURE – 30 PSI
MAX. AIR PRESSURE – 150 PSI
MAX. OUTPUT PRESSURE – 450 PSI
RECOMMENDED OPERATING PRESSURE 80-100 PSI**

OWNERS MANUAL

RETAIN THIS MANUAL FOR FUTURE REFERENCE TO IMPORTANT WARNINGS AND OPERATING AND MAINTENANCE INSTRUCTIONS.

PROPER USE AND MAINTENANCE OF THIS EQUIPMENT IS THE RESPONSIBILITY OF THE OWNER AND/OR OPERATOR.

DO NOT USE THIS EQUIPMENT UNLESS YOU HAVE CAREFULLY READ AND UNDERSTAND THE INSTRUCTIONS AND WARNINGS IN THIS MANUAL.

! WARNING !

- NEVER** exceed the stated maximum working pressure of the pump or of the lowest rated component in your system.
- NEVER** modify any part of this equipment.
- NEVER** use combustible gas with this equipment.
- NEVER** attempt repairs while the system is under pressure.
- NEVER** attempt to disassemble the equipment while the system is under pressure.
- ALWAYS** tighten fluid connections before using this equipment
- ALWAYS** read/follow the fluid manufacturer's recommendations regarding fluid compatibility.
- ALWAYS** read/follow the fluid manufacturer's recommendations regarding the use of protective clothing and equipment.
- ALWAYS** use an air line filter/moisture eliminator at the air inlet for the pump.
- ALWAYS** use air line lubricator.
- REGULARLY** check all equipment and repair/replace worn or damaged parts immediately.

FAILURE TO HEED THESE WARNINGS INCLUDING OVERPRESSURIZING, ALTERING PARTS, USE OF INCOMPATIBLE FLUIDS, MISUSE, OR USE OF DAMAGED/WORN PARTS MAY RESULT IN EQUIPMENT DAMAGE, PROPERTY DAMAGE, FIRE, EXPLOSION AND/OR SERIOUS PERSONAL INJURY.

SAFETY INSTRUCTIONS

Extreme caution should be used when operating this equipment as it generates very high fluid pressure. Leaks from loose or ruptured components or material from dispensing valve can inject fluid through the skin causing serious bodily injury and possible need for amputation. Always wear protection to prevent material splashing onto skin or into eyes. ***IMPORTANT:*** GET EMERGENCY MEDICAL CARE IMMEDIATELY IF ANY FLUID APPEARS TO PENETRATE THE SKIN! INFORM PHYSICIAN OF EXACTLY WHAT WAS INJECTED. PLEASE DO NOT TREAT THIS INJURY AS A SIMPLE CUT.

! WARNING ! – RELIEF PROCEDURE

DO NOT EVER point the dispensing valve at another person.

DO NOT EVER attempt to stop material from the dispensing valve or a leaking connection with your hand or body. **BEFORE EACH USE**, check equipment for proper operation and to insure safety devices are in place and working properly.

NEVER modify this equipment. Modification could cause equipment malfunction and resulting serious bodily injury.

When flushing the pump with solvents, ALWAYS hold a metal part of the dispensing valve firmly to the side of a grounded metal pail and operate pump at the lowest possible fluid pressure to reduce the risk of injury from splashing or static sparking.

WARNING: This pump can develop 450 PSI working pressure at 150 PSI maximum incoming air pressure. Be sure that all system equipment and accessories are rated to withstand the maximum working pressure of this pump.

NEVER exceed the maximum working pressure of the lowest rated component in the system. **IMPORTANT:** “Whip” hoses for dispensing valve are fluid pressure rated at 270 PSI. **NEVER** exceed 90 PSI, air pressure to pump when using “whip” hoses.

WARNING: Water and even moist air can cause this pump to corrode. To aid in the prevention of this corrosion, **NEVER** leave the pump filled with water or air. After normal flushing, flush the pump once more with mineral spirits or an oil based solvent, relieve pressure and leave the mineral spirits in the pump. It is strongly suggested to put 2-4 fl oz of Lubricating Oil in the Air Motor Inlet every week for Proper Lubrication. **Never use a Synthetic Oil as this will cause irreparable damage to the pump. BE SURE TO CORRECTLY FOLLOW THE PRESSURE RELIEF PROCEDURE.**

PRESSURE RELIEF PROCEDURE

ALWAYS FOLLOW THIS PROCEDURE to reduce the risk of serious bodily injury, including splashing into the eyes. After shutting off the pump; checking/servicing any part of the system; installing/cleaning or changing any part of the system, **ALWAYS** follow this procedure:

1. Disconnect the air supply to the pump.
2. Aim the dispensing valve away from yourself and others.
3. Aim the dispensing valve into an appropriate container and open until all pressure is relieved.

If you believe that the dispensing valve or hose is completely clogged or that pressure in the pump has not been fully relieved after following the above procedure, **VERY SLOWLY** loosen the hose end coupling to relieve the pressure gradually and then loosen completely. Then proceed to clear the valve or hose.

WARNING: ALWAYS follow the Pressure Relief Procedure after shutting off the pump.

WARNING: ALWAYS follow the Pressure Relief Procedure when checking/servicing any part of the system and when installing, cleaning or changing any part of the system.

LUBRICATION: It is recommended to lubricate the Air Motor once a week with 2-4fl oz of Common Lubricating Motor Oil injected into the Airlet port of the Air Motor. This will ensure maximum life of the Air Motor. Never use a Synthetic Oil to Lubricate the Air Motor and this will swell the Buna-N rubber packings and cause irreparable damage.

INSTALLATION

It is recommended that you use an **air line filter/regulator/lubricator** to remove harmful dirt and moisture from the compressed air supply and to provide automatic lubrication to the air motor. Blow-dry the lines and hoses with air before connecting them to the system.

ATD5278 PARTS DIAGRAM

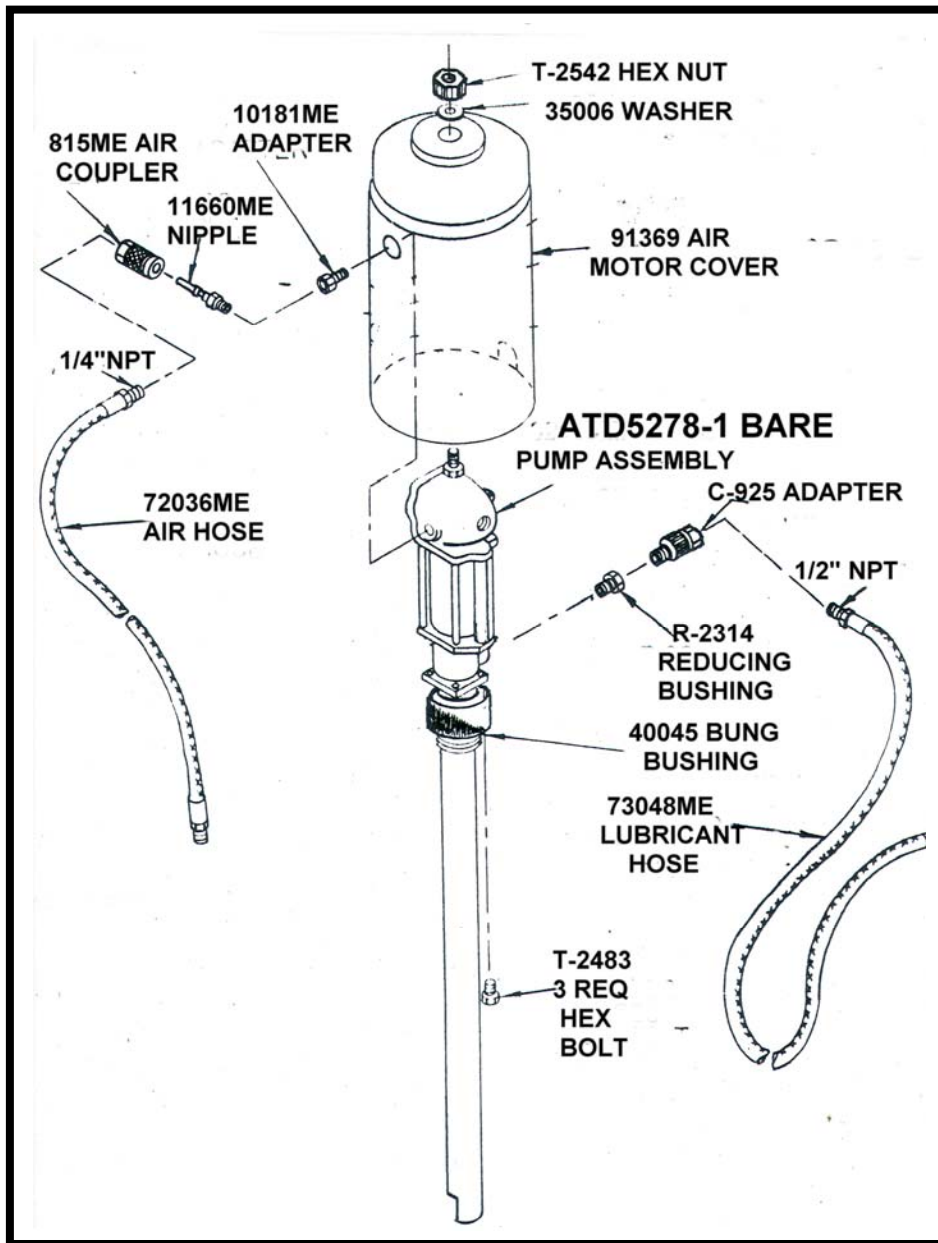

PARTS LIST FOR ATD-5278		
QTY	PART #	DESCRIPTION
1	815ME	QUICK AIR COUPLER
1	11660ME	AIR NIPPLE
1	10181ME	ADAPTER
1	72036ME	AIR HOSE 1/4" NPT X 3FT(.92MTRS)
1	T-2542	HEX NUT FOR MOTOR COVER (11478ME)
1	35006ME	WASHER FOR MOTOR COVER (33034ME)
1	ATD-5278-1	3:1 BARE PUMP ASSEMBLY
1	C-925	HIGH VOLUME SWIVEL ADAPTER 1/2" NPT (M) X 1/2" NPT (F)
1	R-2314	REDUCING BUSHING 3/4 NPT (M) X 1/2" NPT (F)
1	73048ME	OIL HOSE 1/2" NPT (M) X 4FT (1.22MTRS)
1	40045ME	BUNG BUSHING ADAPTER 2" NPT
3	T-2483	HEX BOLT FOR BUNG BUSHING.

PUMP DIMENSIONS AND OPERATION

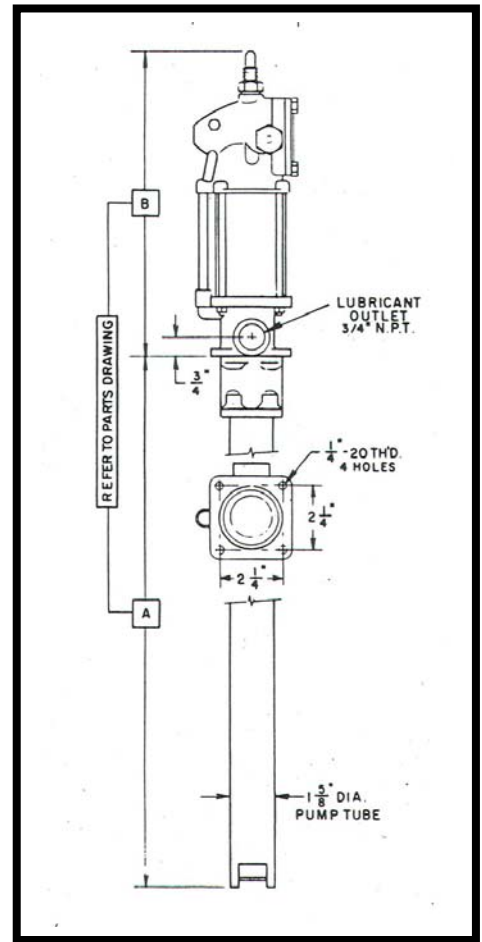
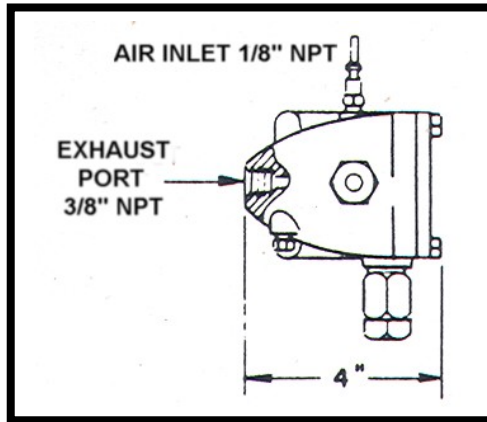

Installation and Operation:

The installations indicated on this sheet are for reference and should be used as a guide only. It is recommended that an air line filter / regulator / lubricator be used to remove dirt & moisture from the air supply line and provide lubrication to the air motor. Before beginning, flush the supply lines & hoses with mineral spirits or a suitable oil base solvent and blow dry with air before connecting the lines to your pump. This is to purge any dirt, metal shavings, contaminants or moisture that might damage the pump or control valves.

This pump has been tested in oil under both a static and dynamic pressure test to ensure the pump operates out of the box. It is recommended that you flush the pump with the fluid you intend to use so as not to contaminate your environment.

Starting: To start the pump, initiate the main air supply line. Open the air regulator slowly until the pump begins to run smoothly. Open the dispensing valve to allow air to be purged from the system. Allow the pump to cycle until all of the air is purged from the system and then release the trigger on the dispensing valve. The pump will continue pumping until it reaches stall pressure. Stall pressure is calculated by multiplying the air pressure on the air regulator by 3; ie 3 x 100 psi so stall pressure is 300 psi of oil pressure. Once the pump reaches stall pressure it will stop automatically, until the trigger on the dispensing valve is pulled releasing fluid under pressure and then the pump will start cycling to build stall pressure again and then stop once stall pressure is reached again.

Use the air regulator to control the speed of the pump and the fluid pressure. The recommended operating air pressure is 80 to 100 psi. Anything above 100 psi up to 150 psi reduces pump life considerably.

If the pump operates rapidly or is running too fast, shut off the air supply immediately and check the fluid lubricant lines for leaks, if necessary.

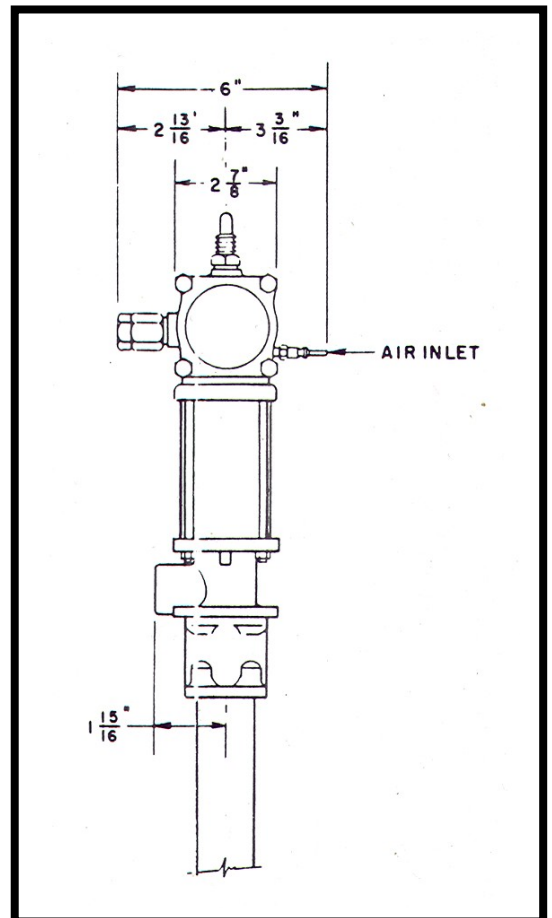

CROSS SECTION DIAGRAM OF TOP PORTION OF FLUID PUMP ATD-5278-1

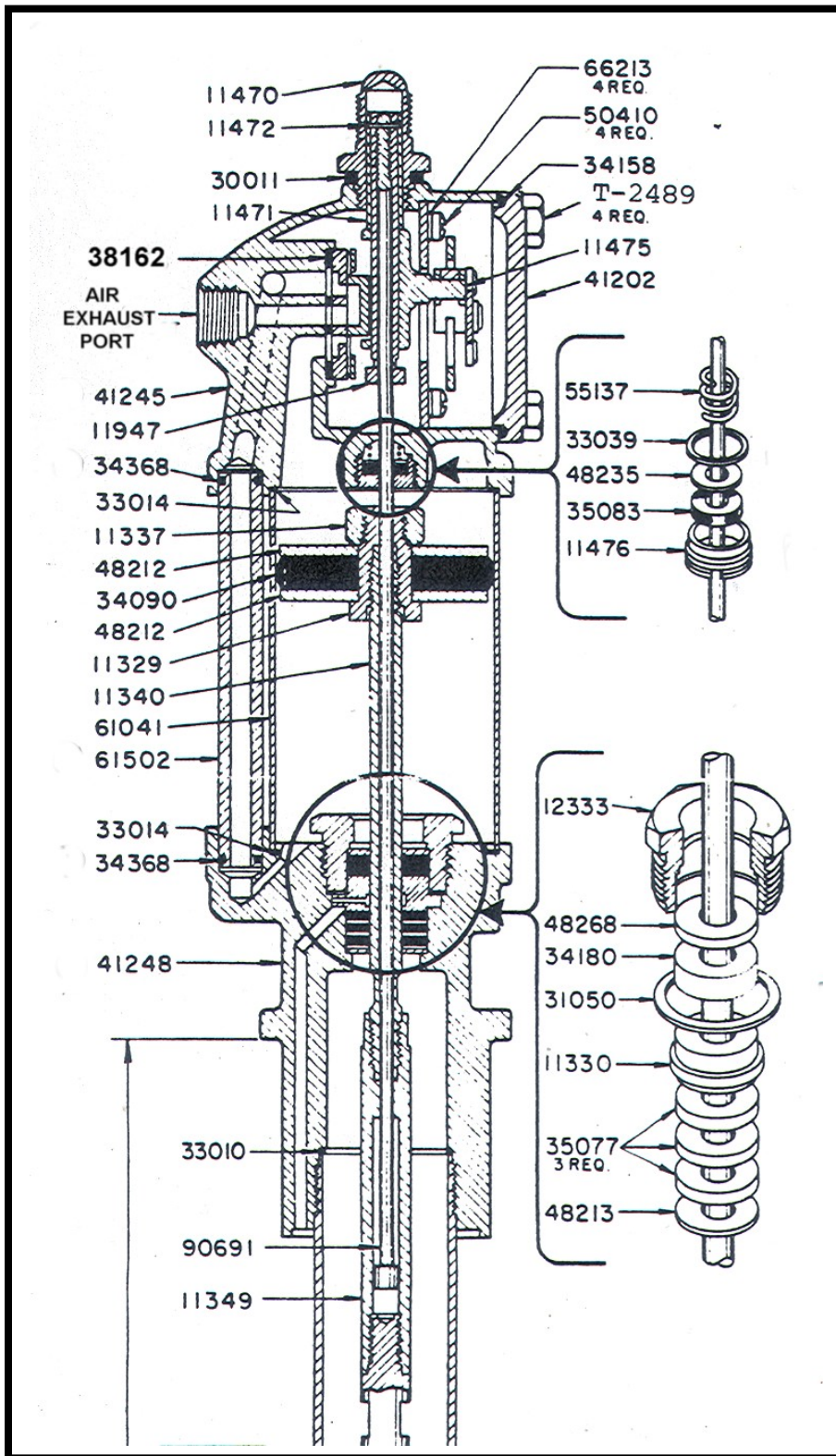

CROSS SECTION DIAGRAM OF LOWER SECTION OF FLUID PUMP ATD5278-1

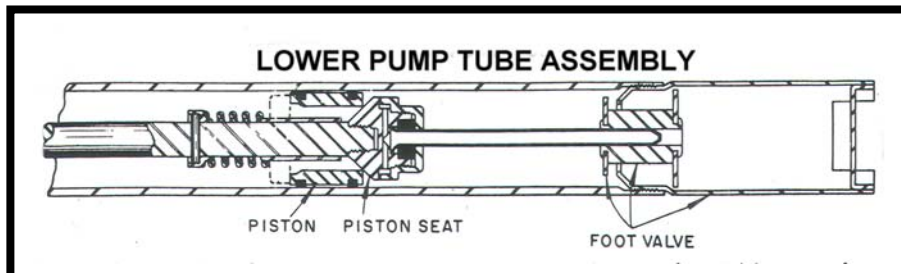
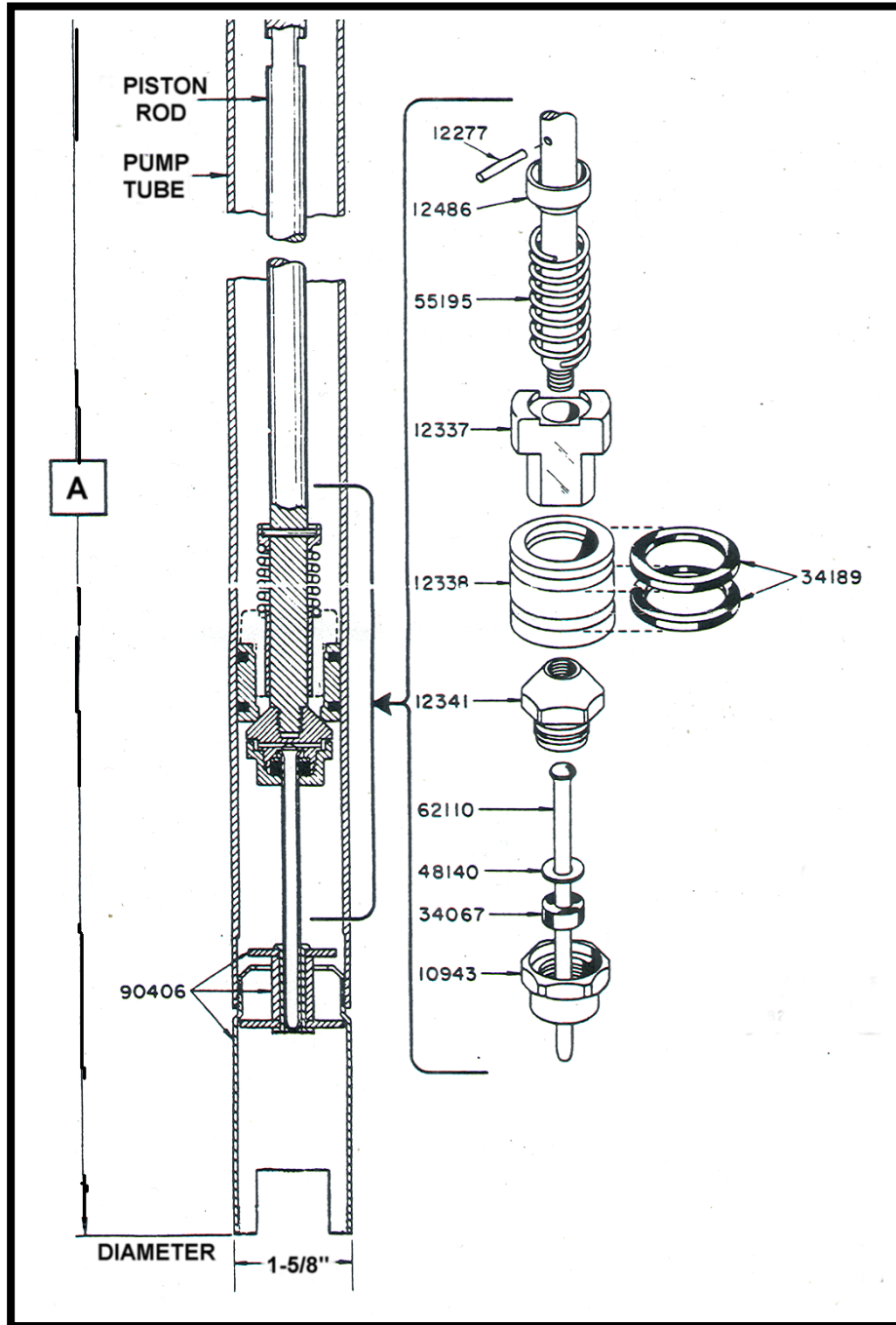

AIR MOTOR DIAGRAM

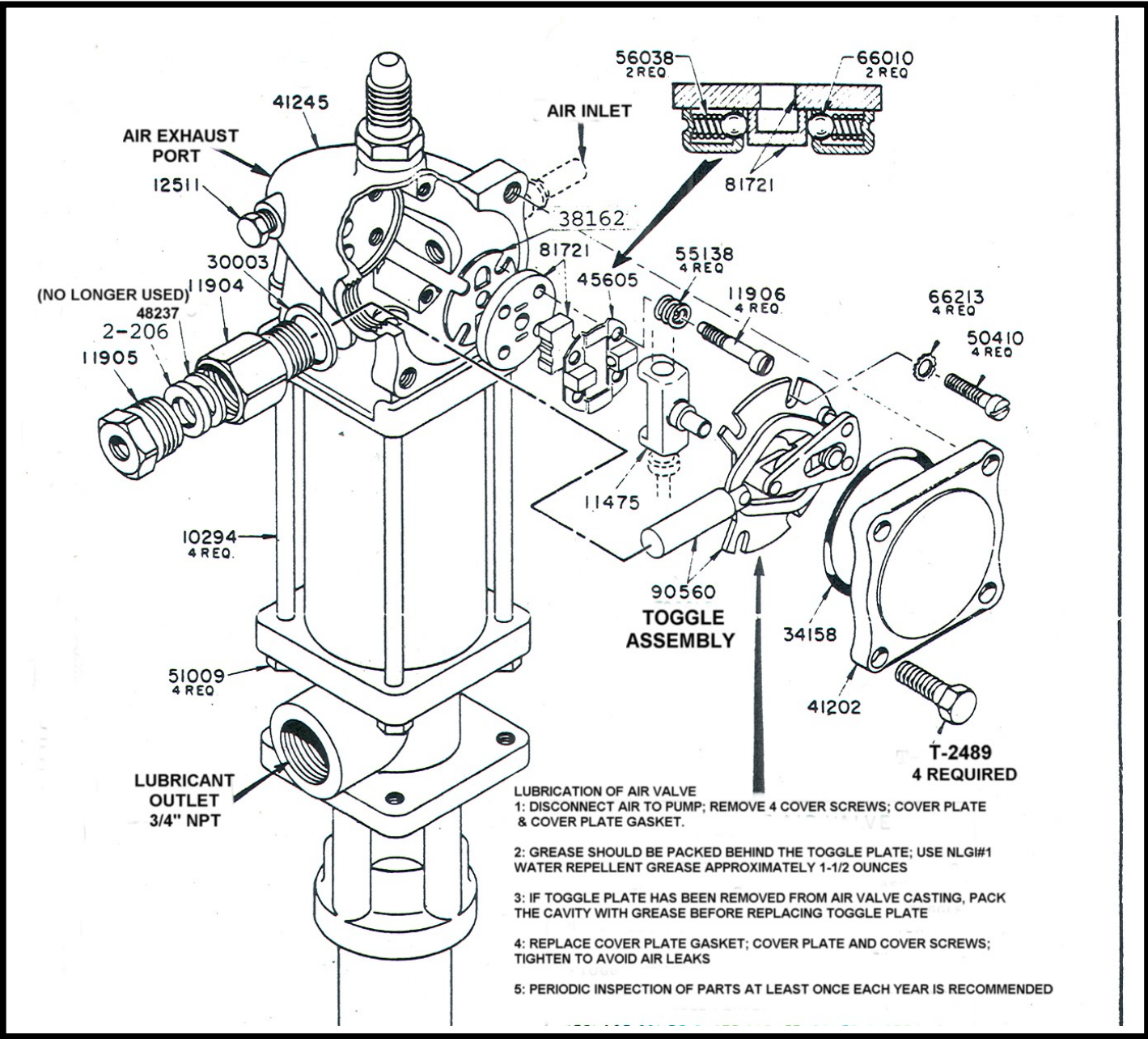

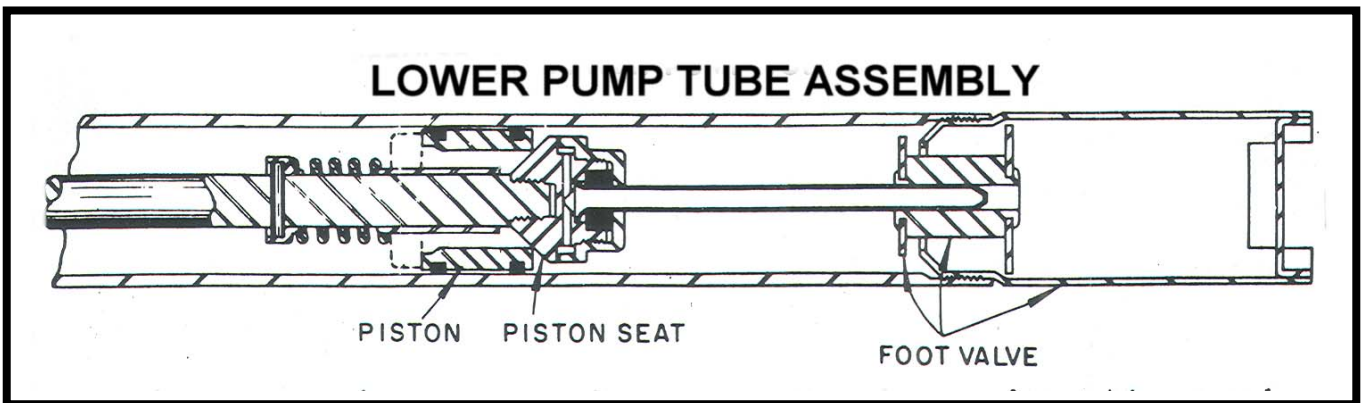
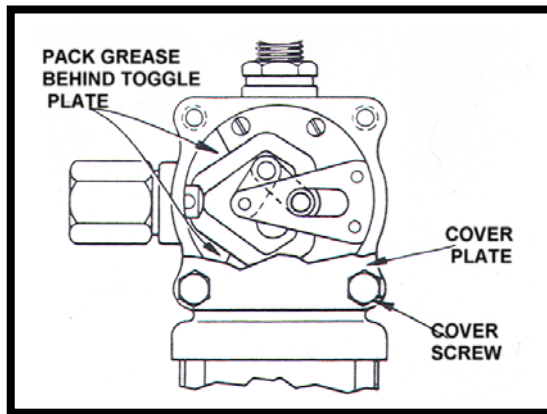
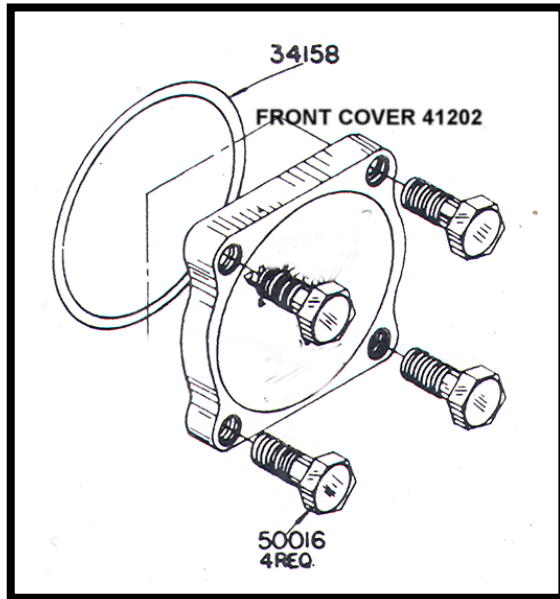
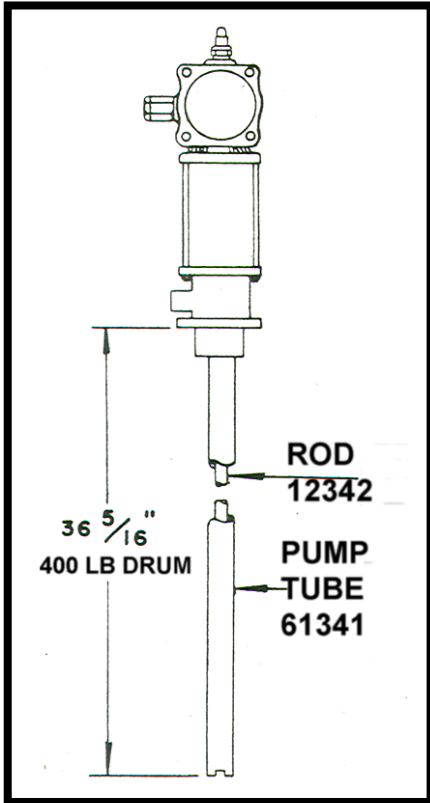
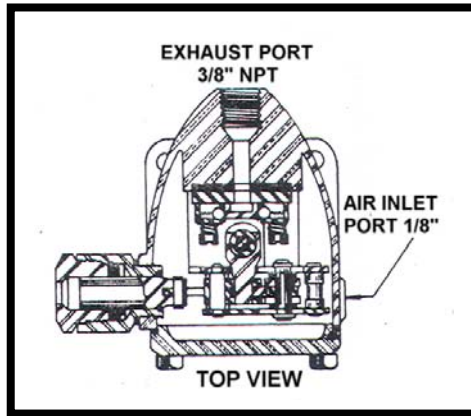
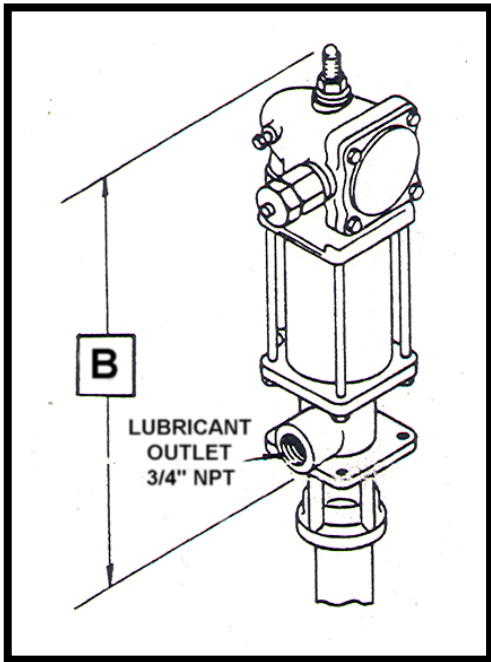

PARTS LIST FOR ATD5278-1

PART#	DESCRIPTION	QTY	PART#	DESCRIPTION	QTY
10294	TIE ROD	4	34180	GLAND PACKING	1
10943	PISTON SEAT CAP	1	34189	PISTON PACKING	2
11329	AIR PISTON BOLT	1	34368	O-RING	2
11330	GLAND PACKING SPACER	1	35077	GLAND PACKING	1
11337	AIR PISTON NUT	1	35083	TRIP ROD PACKING	1
11340	AIR MOTOR PISTON ROD	1	38162	VALVE SEAT GASKET(38048)	1
11349	PISTON ROD CONNECTOR	1	41202	COVER CASTING	1
11470	VALVE CAP	1	41245	AIR VALVE CASTING	1
11471	TRIP ROD COLLAR	1	41248	OUTLET CASTING	1
11472	TRIP ROD PIN	1	45605	VAVLE GUIDE PLATE	1
11475	TRIP SHOE	1	48140	PACKING WASHER	1
11476	TRIP ROD PACKING NUT	1	48212	AIR PISTON WASHER	2
11904	PACKING NUT	1	48213	GLAND PACKING WASHER	1
11905	PACKING CAP	1	48235	PACKING WASHER	1
11906	VALVE SEAT BOLT	4	48237	PLUNGER PACKING WASHER	1
11947	TRIP SLEEVE	1	48268	PACKING WASHER	1
12277	PIN	1	T-2489	VALVE COVER SCREW (T-2489)(50016)	4
12333	PACKING NUT	1	50410	TOGGLE PLATE SCREW	4
12337	SPRING STOP	1	51009	TIE ROD NUT	4
12338	PISTON	1	55137	TRIP ROD PACKING SPRING	1
12341	PISTON SEAT CAP	1	55138	VALVE SEAT SPRING	4
12342	PISTON ROD	1	55195	SPRING	1
12486	PIN RETAINER	1	56038	SPRING	2
12511	PIPE PLUG	1	61041	AIR CYLINDER	1
30003	PACKING NUT GASKET	1	61341	PUMP TUBE	1
30011	VALVE CAP GASKET	1	61422	PUMP TUBE	1
31050	GLAND GASKET	1	61502	AIR PASSAGE TUBE	1
33010	PUMP TUBE GASKET	1	62110	AIR EXPELLER TUBE	1
33014	AIR CYLINDER GASKET	2	66010	STEEL BALL	4
33039	PACKING NUT GASKET	4	66213	LOCKWASHER	1
34067	PISTON SEAT PACKING	1	81721	VALVE SLIDE & SEAR ASSY	1
34090	AIR PISTON PACKING	1	90406	FOOT VALVE ASSEMBLY	1
2-206	PLUNGER PACKING(34206)	1	90560	TOGGLE PLATE ASSEMBLY	1
34158	COVER GASKET	1	90691	TRIP ARM ASSEMBLY	1

ATD5321 REPAIR KIT CONTENTS REPAIR KIT FOR ATD-5278 & ATD-5278-1 OIL PUMP

QTY	PART #	DESCRIPTION	QTY	PART #	DESCRIPTION	
1	11340	AIR MOTOR PISTON ROD	1	34180	GLAND PACKING	
1	11472	TRIP ROD PIN	2	34189	PISTON PACKING	
1	12338	PISTON	1	34206	"O" RING	
1	12341	PISTON SEAT	2	34368	"O" RING	
1	30003	PACKING NUT GASKET	3	35077	GLAND PACKING	
1	30011	VALVE CAP GASKET	1	35083	TRIP ROD PACKING	
1	31050	GLAND GASKET	1	38162	VALVE SEAT GASKET	
1	33010	PUMP TUBE GASKET	1	48235	PACKING WASHER	*****
2	33014	AIR CYLINDER GASKET	1	55137	TRIP ROD PACKING SPRING	
1	33039	PACKING NUT GASKET	1	56038	SPRING	
1	34067	PISTON SEAT PACKING	2	66010	EQUALIZER BALL	
1	34158	COVER GASKET	4	66213	LOCK WASHER	
			1	34110	PACKING PLUNGER	*****

ATD5278 W/ COVER ATD5360 PARTS DIAGRAM

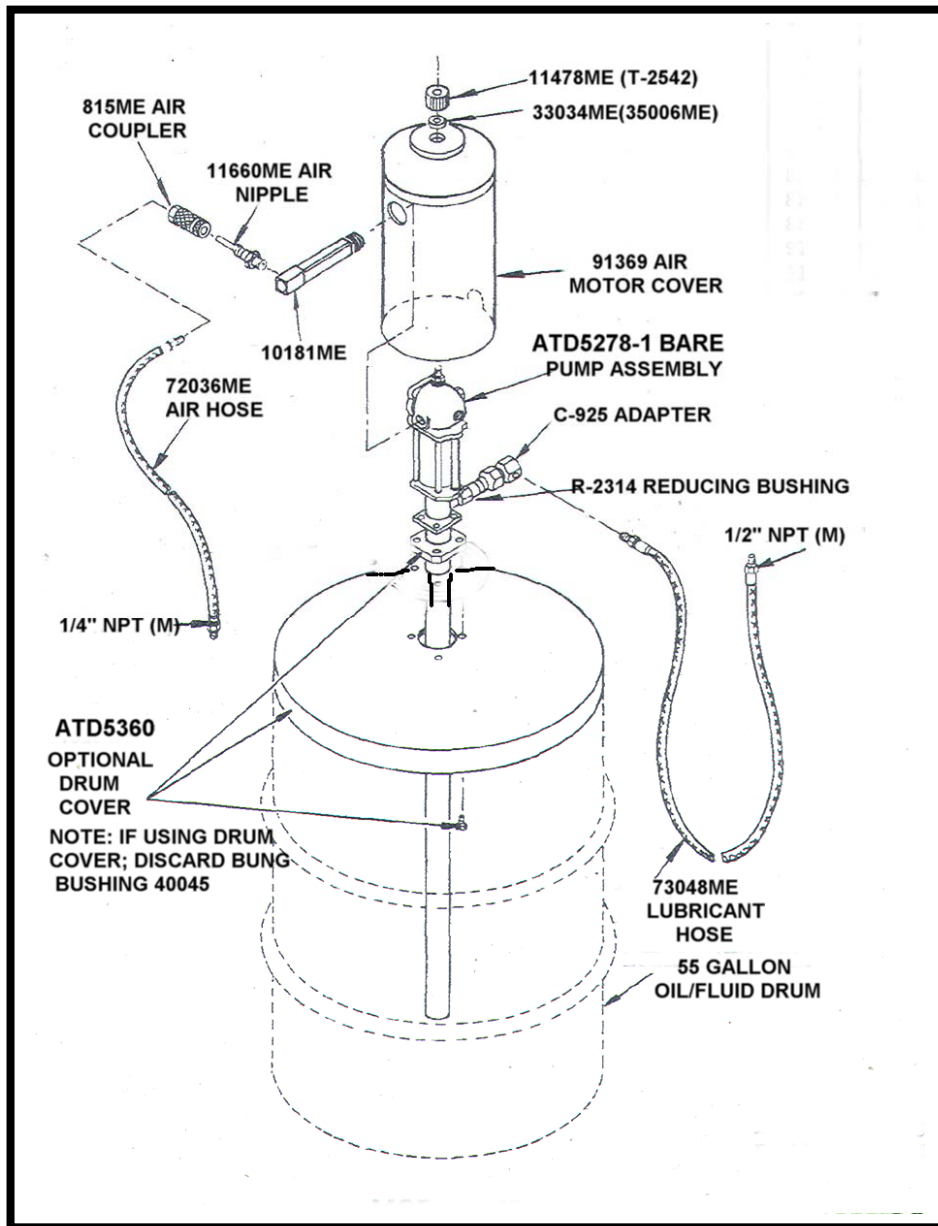

PARTS LIST FOR ATD5278

QTY	PART #	DESCRIPTION
1	815ME	QUICK AIR COUPLER
1	11660ME	AIR NIPPLE
1	10181ME	ADAPTER
1	72036ME	AIR HOSE 1/4" NPT X 3FT(.92MTRS)
1	T-2542	HEX NUT FOR MOTOR COVER (11478ME)
1	35006ME	WASHER FOR MOTOR COVER (33034ME)
1	ATD5278-1	3:1 BARE PUMP ASSEMBLY
1	C-925	HIGH VOLUME SWIVEL ADAPTER 1/2" NPT (M) X 1/2" NPT (F)
1	R-2314	REDUCING BUSHING 3/4 NPT (M) X 1/2" NPT (F)
1	73048ME	OIL HOSE 1/2" NPT (M) X 4FT (1.22MTRS)
1	40045ME	BUNG BUSHING ADAPTER 2" NPT
3	T-2483	HEX BOLT FOR BUNG BUSHING.
1	81523ME	DRUM COVER FOR 55 GALLON DRUM