

Trolley Mounted Grease Pump Kit

ATD-5225

Trolley mounted kits are ideal for use in workshops, garages, shop floors providing complete portability for everyday greasing jobs

Designed for use with 400lbs Grease Drums, these come complete with

- 50:1 Air Operated Grease Pump
- Steel Drum Cover with chain
- Rubber Lined Follower Plate
- Grease Hose Reel with 10m (30') x 1/4" Grease Hose
- Grease Control valve fitted with Z Swivel
- Drum Trolley with chain to hold the drum

- 1/4" Miniature Air Filter-Regulator Combination
- Hose for connecting pump outlet to reel inlet

Kit comes in CKD form & can be assembled quickly.

Trolley can be locked with brakes provided on the wheels with brakes provided on the wheels

WORKING PRESSURE	DELIVERS
30-150 PSI (2-10 BAR)	UPTO 1.1 KG / MIN (2.42 LBS / MIN)

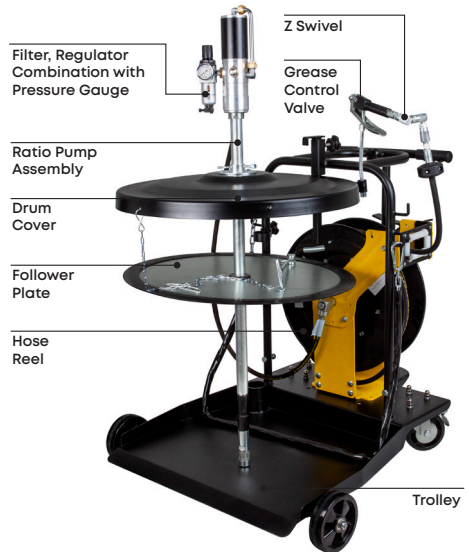

SPECIFICATIONS

PUMPTYPE	Air Operated 50:1
GREASE OUTPUT (NLGI NO. 2 GREASE)	1.10 kg/min. (2.42 lbs/min.)
WORKING PRESSURE	2-10 BAR (30-150 PSI)
MAXIMUM AIR INLET PRESSURE	10 BAR (150 PSI)
MAXIMUM OUTLET PRESSURE	7,500 PSI (500 BAR)
AIR INLET CONNECTION	1/4" (F) NPT
PUMP OUTLET CONNECTION	1/4" (F) NPT
AIR CONSUMPTION	230 LPM (61 GPM)
RECOMMENDED USE	Up to NLGI No. 2
HOSE REEL	Grease Hose reel (Dual Arm) complete with 10m (30') x 1/4" ID Rubber Hose
CONNECTING HOSE	Rubber Hose 1.5m (5') x 1/4" ID
GREASE CONTROL VALVES	Professional Grease Control Valve fitted with 360° Z Swivel & Comes complete with 6" steel extension & coupler
AIR CONTROL UNIT	Miniature 1/4" Air Filter-Regulator Combination with Pressure Gauge, 40 Micron Filter, 20 CFM (550 LPM)
NOISE LEVEL	81 db

CAT NR.	FITS	DRUM COVER DIAMETER		FOLLOWER PLATE DIMENSIONS					
		(INCH)	(MM)	O.D. STEEL END		O.D. PLATE		I.D. GROMMET	
NPT THREADS				(INCH)	(MM)	(INCH)	(MM)	(INCH)	(MM)
TMK/GP3H/A/N	400lb / 180 kg drums	24-1/2	612	21-5/8	550	23-11/16	602	1.16	29.5



SAFETY INFORMATION

- Follow workshop health & safety rules, regulations and conditions when using the trolley mounted grease pump kit.
- During their period of use, accessories must be checked for wear, cracks and other damage, replace any damaged or worn parts.
- Use genuine parts only. Unauthorized parts may be dangerous and will void the warranty.
- Wear approved safety gloves and eye and ear protection.
- Keep the trolley mounted grease pump kit clean and in good working order for best and safest performance.

WARNING!

- DO NOT use the trolley mounted grease pump kit for a task it is not designed to perform.
- DO NOT use the trolley kit if damaged or thought to be faulty. Contact your local service agent.

PACKAGE CONTENT

DESCRIPTION	QUANTITY
50:1 Grease Ratio Pump	1
Follower Plate	1
Drum Cover with chain	1
Grease Hose Reel	1
1.5 m (5 ft) connecting hose	1
Grease control valve with z swivel	1
Trolley base plate	1
Carrier assembly	1
Handle assembly	1
Trolley attachment set	1
Miniature Air Filter-Regulator Combination	1
Hardware set	4
O.I.P.M.	1

TOOLS NEEDED

- 10 mm Spanner
- 11 mm spanner / 7/16" spanner
- 12 mm Spanner
- 14 mm spanner / 9/16" spanner
- 17 mm spanner / 11/16" spanner
- 19 mm spanner / 3/4" spanner
- 24 mm spanner / 15/16" spanner
- 25 mm spanner / 1" spanner
- Phillip Screw Driver (PH 2)

BEFORE INSTALLATION

- Use only original accessories compliant with this trolley mounted grease pump kit.
- Make sure that all connections are secure.
- **Pump construction:** The pump is made up of two sections
- **Drive section:** It consists of an air motor assembly driven by compressed air. The piston diameter of the air motor is 2.5" (63 mm).

The motor consists of an air cylinder with piston and one reciprocal valve with a nylon slider. The valve directs the compressed air alternately to the top or bottom of the piston, thus producing a reciprocating motion of the piston rod.

- **Pumping Section:** It consists of a pump in which a piston lifts media through non return valves by reciprocating inside the suction tube. Grease is discharged with pressure (from the outlet located at bottom of Air Motor) into the delivery hose / pipe.
- **Air motor** of this pump starts automatically when the grease control valve is opened. When the grease control valve is closed, air motor builds up a back-pressure and stops operating the pumping section.
- **Pressure ratio** of the pump states the ratio of the output fluid pressure to the incoming air pressure. When the pressure ratio is 50:1, we achieve an output grease pressure up to 7500 PSI (500 BAR) when the incoming air pressure is 150 PSI (10 BAR).

WARNING!

- Defective accessories can lead to personal injury and material damage

INSTALLATION

1. Insert the 2 pump clamps in the carrier assembly and hand tighten it using the knob.

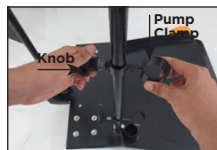

Note: There must be adequate distance between the two clamps

Note: The 2 pump clamps should be on the same side as of the welded cavity on the base plate.

2. Tighten the carrier assembly with the base plate using one pair of nut and bolt on each side.

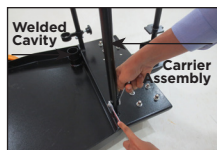

3. Fix the handle by inserting it into the handle slot and lock it by rotating the knob in clockwise direction.

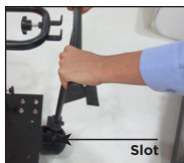

Mounting the pump

1. Pass the pump barrel through 2 pump clamps on the trolley.



2. Attach the filter, regulator combination to the pump air inlet.



Mounting the hose reel

1. Mount the hose reel on the trolley using 4 bolts, nuts and washers of 17mm provided with the kit



2. Connect the grease control valve with the hose reel outlet using wrench.



3. Connect one end of the connecting hose to the pump outlet and other end to the hose reel inlet using swivel.



4. Use a wrench to tighten connecting hose to the pump outlet.

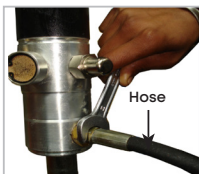

Mounting the drum on trolley

1. Lock both the front castors by pressing it with foot.



2. Place the grease drum on the trolley's base plate
3. Adjust the drum clamp according to the height of the drum and rotate the knob in clockwise direction to lock the drum on the trolley.

Mounting the pump over drum

1. Fill the drum with Grease leaving empty space of about 2" from the top rim. Shake the drum after it is filled to remove air pockets. Place the follower plate in the grease drum with the lift handle facing upwards. Push the follower plate down, until some grease is forced through the centre hole on the plate.

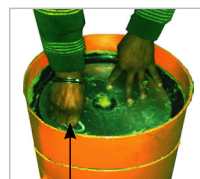

2. Connected the drum cover to the follower plate with the help of chain provided with the drum cover. Now place the drum cover on the drum. Lift the pump assembly & slide the suction tube through the drum cover & centre hole in the follower plate.



3. Push the pump assembly down till the bottom of the pump touches the base of the drum. Adjust the drum cover and tighten it with the thumb screws provided along with the drum cover.





4. Tighten the drum cover with the pump suction tube with the help of thumb screws.

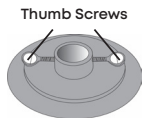

5. With the air supply turned off, connect the air line into the FRC (Filter-Regulator Combination).

CAUTION!

- An FRC (Filter-Regulator Combination) unit must be used in the Air supply, before it is connected to the pump. Set the regulator to 90 PSI (6 Bar) or any required inlet pressure, but never more than 150 PSI (10 Bar) or less than 30 PSI (2 Bar). When not in use & at the end of each day, air supply to the pump must be switched off.
- Tighten the nuts and bolts for rigid assembly.
- Apply thread sealant on all threaded connections to ensure leak-proof operation.

OPERATING INSTRUCTIONS

1. Partially open the on/off air valve (It helps in creating initial vacuum when filling a totally dry pump). Pump will start operating automatically until it gets primed. Pump is said to be Primed when grease is available at the pump outlet, making the pump ready to use. Once primed, the air motor will stop. Open the on/off air valve fully.

2. Hold the grease control valve near a container & press the trigger. Pump will start operating with continuous grease discharge as long as the trigger is pressed. Release the trigger & this will stop the pump. Check for any leaks from any of the connections & tighten again if required.

3. Connect coupler fitted onto the control valve extension with the grease fitting & press trigger. Be careful not to over-lubricate as the pump will keep dispensing grease as long as the trigger is pressed. Once the trigger is released, pump will stop dispensing grease & the air motor will stop.



4. When not in use & at the end of each day, air supply to the pump must be switched off.

MAINTENANCE

- Grease pump and hose should be kept clean and checked for damage before each use.
- Use an air supply system that incorporates a filter, regulator combination.
- Every week clean the FRC (Filter-Regulator Combination) unit, connecting hose & grease control valve hose so the pump remains free from contamination.

EXPLODED VIEW

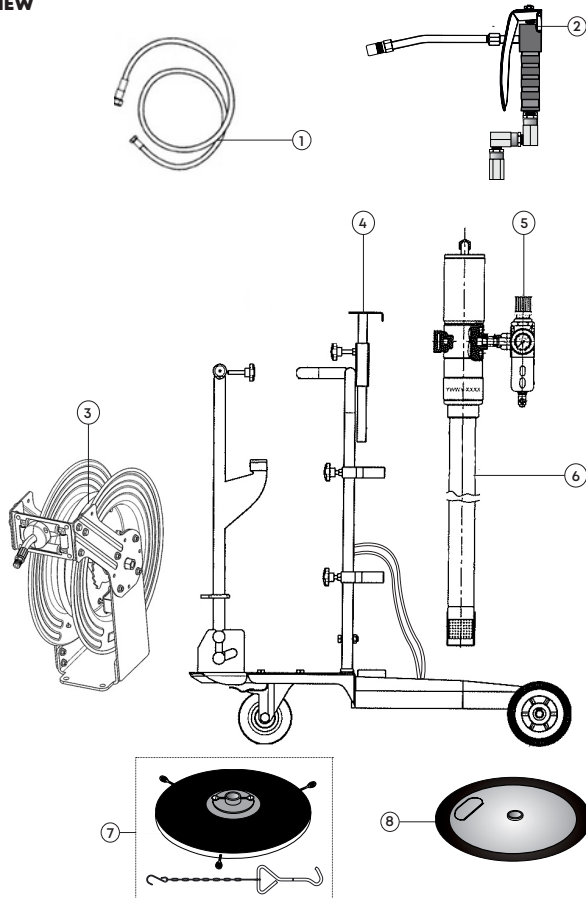

PART LIST

REF NO.	PARTS DESCRIPTION	QUANTITY
1	1.5 meter (5 ft.) connecting hose	1
2	Grease control valve with Z-swivel (Complete exploded and part list on page 6)	1
3	Hose reel (Complete exploded and part list on page 7)	1
4	Trolley with chain to hold the drum	1
5	FRC unit	1
6	Grease ratio pump 50:1 (Complete exploded and part list on page 8)	1
7	Drum cover with chain to hold the follower plate	1
8	Follower plate	1

**EXPLODED VIEW
(Grease control valve)**

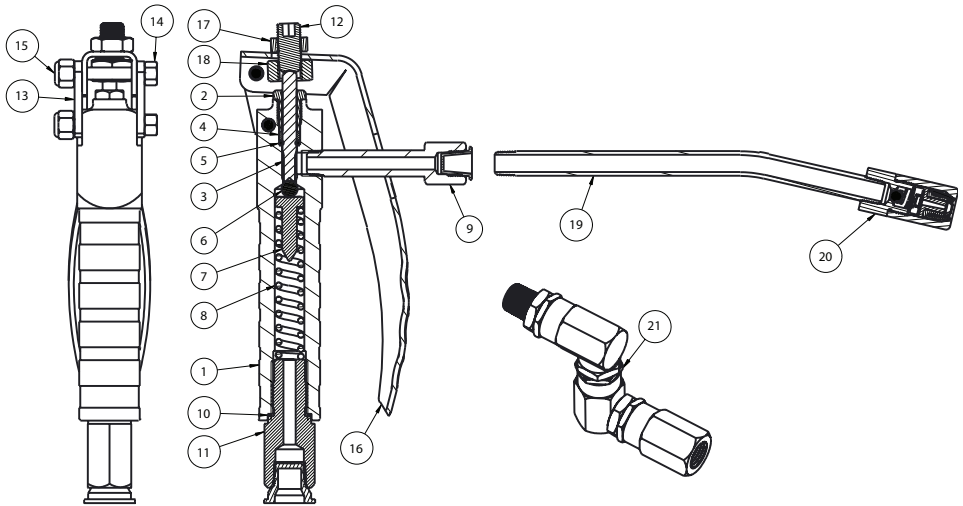

**PART LIST
(Grease control valve)**

REF NO.	PARTS DESCRIPTION	QUANTITY
1	Valve body	1
2	Rod guide	1
3	Piston	1
4	Teflon washer	1
5	O-Ring	1
6	Steel ball	1
7	Ball retainer	1
8	Straight spring	1
9	Valve outlet	1
10	Brass washer	1
11	Valve Inlet	1

REF NO.	PARTS DESCRIPTION	QUANTITY
12	Grub screw	1
13	Side clip	2
14	Rivet	2
15	Nyloc nut	2
16	Handle	1
17	Lock Nut	1
18	High nut	1
19	Extension (Rigid)	1
20	Coupler	1
21	Z-swivel	1



**EXPLODED VIEW
(Hose Reel)**

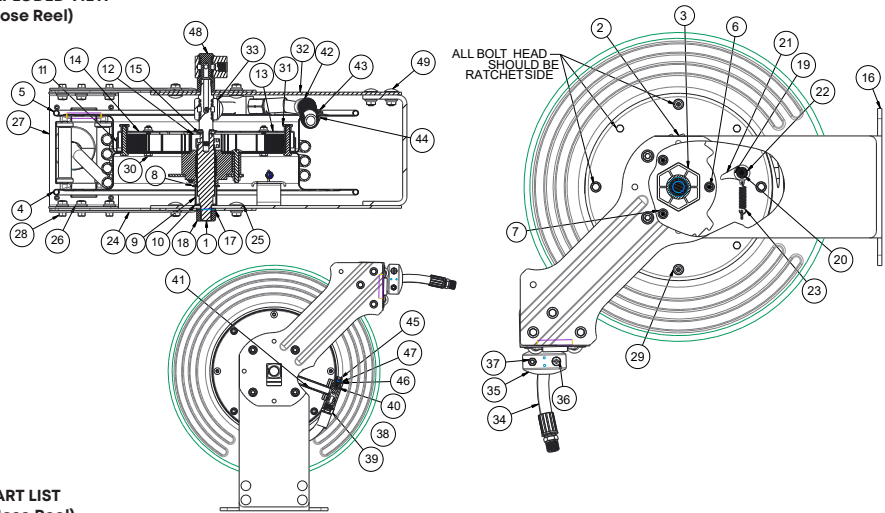

**PART LIST
(Hose Reel)**

REF NO.	PARTS DESCRIPTION	QUANTITY.
1	Shaft	1
2	Ratchet Plate	1
3	Holder (Ratchet Plate)	1
4	Sheave (Right)	1
5	Sheave (Left)	1
6	Square Neck Bolt	3
7	Flange Nut	7
8	Steel Washer	1
9	Spacer	1
10	Steel Washer	2
11	Cover (Coil Spring)	1
12	Coil Spring Guide	1
13	Coil Spring (Power spring)	1
14	Cover (Coil Spring)	1
15	External Circlip	1
16	Base Plate.	1
17	Spring Washer	2
18	Nut	1
19	Flange Bolt	1
20	Bush	1
21	Latch	1
22	Flange Nut	1
23	Extension spring	1
24	Side Bracket	2
25	Square neck Bolt	8

REF NO.	PARTS DESCRIPTION	QUANTITY.
26	Flange nut	18
27	Roller Plate	1
28	Flange Bolt	6
29	Steel Washer	4
30	Bolt	8
31	Nut (Spring Cover)	4
32	Leg (Left)	1
33	Swivel	1
34	Hose	1
35	Hose Stopper	1
36	Screw	2
37	Lock Nut	2
38	Hose Connector	1
39	Hose Adaptor	1
40	O-ring	2
41	Pipe	1
42	Hose Clip	2
43	Screw	2
44	Hex Domed Nut	2
45	Allen Bolt	1
46	Steel Washer	1
47	Spring Washer	1
48	Inlet Swivel	1
49	Square Neck Bolt	4

EXPLODED VIEW
(Grease ratio pump 50:1)

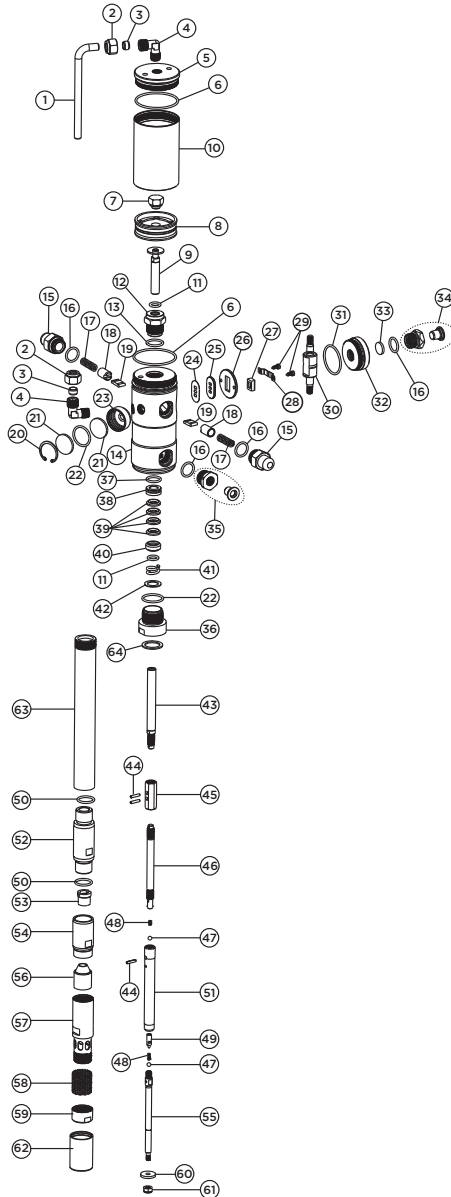



PART LIST
(Grease ratio pump 50:1)

REF. NO.	DESCRIPTION	QUANTITY
1	Bend Pipe	1
2	Coupling Nut	2
3	Sealing Ring	2
4	Bend	2
5	Cylinder Cover	1
6	O Ring (BS14)	2
7	Plunger Nut	1
8	Rubber Plunger	1
9	Plunger Rod	1
10	Cylinder	1
11	O Ring (BS614)	2
12	Rod Guide	1
13	O Ring (BS116)	1
14	Housing	1
15	Pusher	2
16	O Ring BS617	4
17	Pusher Spring	2
18	Pusher Nut	2
19	Pusher Button	2
20	Circlip	1
21	Filter (B)	2
22	O Ring (BS121)	2
23	Exhaust Valve	1
24	Paper Seal	1
25	Seat	1
26	Slider Guide	1
27	Nylon slider	1
28	Clip	1
29	Self Tapping Screw	2
30	Slider	1
31	O Ring (BS129)	1
32	Inlet Cover	1

REF. NO.	DESCRIPTION	QUANTITY
33	Filter (S)	1
34	Air Inlet Adapter	1
35	Outlet Adapter	1
36	Adapter	1
37	O Ring (BS115)	1
38	Seal Guide	1
39	Seal	4
40	Seal Support	1
41	Spring (Seal)	1
42	Steel Washer	1
43	Connecting Rod	1
44	Slotted Spring Pin	3
45	Connector	1
46	Extension Rod	1
47	Steel Ball (7/32")	2
48	Non Return Spring	2
49	Valve	1
50	O ring (BS812)	2
51	Pump Cylinder	1
52	Top Coupler	1
53	Slide Bush	1
54	Bottom Coupler	1
55	Piston Rod	1
56	Guide Bush	1
57	Filter Tube	1
58	Filter	1
59	End Cap (Filter)	1
60	Piston Washer	1
61	Nyloc Nut	1
62	Filter Cap	1
63	Barrel	1
64	Rubber Washer	1



TROUBLESHOOTING

Refer "Exploded View (Grease ratio pump 50:1)"

PROBLEM	POSSIBLE CAUSE	CORRECTIVE ACTION
Pump operates, but does not dispense any grease	Grease is too thick / too cold	Store grease in a warm place
	Air pockets in grease	Shake the Grease bucket & manually force down the Follower Plate (65) to remove air pockets
	Dent in the Grease Bucket restricting movement of Follower Plate (65) leading to formation of air pockets in the bucket and inefficient working	Get the dent removed to ensure proper movement of Follower Plate (65)
Pump not working / less discharge	Inlet pressure is too less	Increase inlet pressure. It must be at least 30 PSI (2 BAR)
	Nylon Slider (27) is jammed / over tight	Check for any build-up edge on Clip (28) & tighten it again. Make sure the movement of Nylon Slider (27) is neither very loose nor very tight If needed, replace Nylon Slider (27). Also replace the Paper Seal (24), Seat (25) & Slider Guide (26) to ensure the best fitting
	Piston / Piston Rod / Plunger jammed. NOTE Especially check Extension Rod (46), Pump Cylinder (51), Top Coupler (52), Slide Bush (53) & Piston Rod (55)	Remove suction tube. Disconnect air motor assembly from pumping section by removing the upper Slotted Spring Pin (44) from Connector (45) Supply input air to air motor. If it works properly without the barrel assembly, then the problem lies with the pumping section. Otherwise check the air motor for smooth movement After locating the faulty section, check the respective Piston / Plunger & the associated washers & seals for any overlap or wear & tear. Replace the defective parts Ensure to replace the moving parts having close tolerances (such as Piston & Cylinder along with Non Return Springs & balls) as a set to ensure the best fitting
Pump continues to operate even after the trigger of Grease Control Valve (69) has been released	Leakage in the assembly	Check all the connections to ensure they are air tight. Use thread sealant. Check O rings & seals for damage. Replace the defective parts
Grease comes through the air Exhaust Valve (23)	Grease leaks into the air motor	Check Seal Guide (38), O Ring (37), lower O Ring (11), Seals (39) & Seal Support (40) for wear & tear. Replace the damaged parts
Air passes directly from inlet to the outlet & pump does not work	Nylon Slider (27) is jammed / over tight	Check for any build-up edge on Clip (28) & tighten it again. Make sure the movement of Nylon Slider (27) is neither very loose nor very tight If needed, replace Nylon Slider (27). Also replace the Paper Seal (24), Seat (25) & Slider Guide (26) to ensure the best fitting
Discharge suddenly stopped while the pump was running	Seals / O Rings Damage	Check all seals / O Rings & replace the damaged parts
	Chip / Other foreign particles get clogged at discharge coupler	Open the coupler, remove all foreign particles / chips & reassemble properly
	Clogging of Filter Tube (57) and Filter (58)	Open Filter Cap (62) & End Cap (59), clean Filter Tube (57), Filter (58) & reassemble it properly



DISPOSAL

The components or the used products must be given to companies that specialize in the disposal and recycling of industrial waste.