



ATD-2088

Random Orbital Palm Sander



Features:

- Low profile design with ergonomic cushion grip
- Random orbital action assures a swirl-free finish
- Variable air speed control
- 3/16" orbit for rapid material removal
- Application: Paint prep and finishing
- Sanding Pad: 6" diameter PSA-style

Specifications:

- Working Pressure: 90 psi
- Free Speed: 10,000 rpm
- Air Inlet Thread: 1/4" NPT
- Hose Size: 3/8"
- Average Air Consumption: 2.8 CFM
- Maximum Air Consumption (continuous run with load): 5.1 CFM
- Minimum Air Compressor Hp Needed: 2 Hp +
- Net Tool Weight: 2.2 lbs.
- Shipping Weight: 2.8 lbs.

Includes:

Oil, 6" vinyl face pad, wrench, orbital sander and 1/4" male nipple



WARNING



WARNING: This product contains chemicals, including lead, known to the State of California to cause cancer, birth defects or other reproductive harm. *Wash hands after handling.*

CA Prop 65 Warning:

 **WARNING:** This product contains chemicals including lead, known to the State of California to cause cancer, birth defects, or other reproductive harm. Wash hands after handling.

 **WARNING:** Some dust created by power sanding, sawing, grinding, drilling and other construction activities contains chemicals known to the State of California to cause cancer, birth defects, or other reproductive harm.

Some examples of these chemicals are:

- Lead from lead based paint
- Crystalline silica from bricks, cement, and other masonry products
- Arsenic and chromium from chemically treated lumber

Your risk from exposure varies, depending on how often you do this work. To reduce your exposure to these chemicals: work in a well-ventilated area with approved safety equipment, such as dust masks that are specifically designed to filter out microscopic particles.

General Safety Warnings:

 **WARNING:** The instructions and warnings contained in this manual should be read and understood before using or operating this tool. Do not allow anyone to use or operate this tool until they have read this manual and have developed a thorough understanding of how this tool works. Failure to observe any of the following instructions could result in severe personal injury to tool user and bystanders, or cause damage to the tool and property. Keep this manual for future reference.





Note: The warnings and cautions discussed in this instruction manual cannot cover all possible conditions and situations that may occur. It must be understood by the operator that common sense and caution are factors which cannot be built into this product, but must be supplied by the operator.

 **WARNING:** Use safety equipment. User and bystanders should use safety goggles or safety glasses with side shields which comply with current national standards, or when needed, a face shield. Use an ANSI approved dust mask or respirator when working around metal, wood, and chemical dusts and mists. This applies to all persons in the work area. Also use non-skid safety shoes, hardhat, gloves, dust collection systems, and hearing protection when appropriate.

 **WARNING:** Keep bystanders and children out of the work area while operating this tool.

 **WARNING:** Always keep your work area clean, uncluttered, and well lit. Cluttered or dark areas invite accidents and injuries. DO NOT work on floor surfaces that are slippery.

 **WARNING:** Do not operate this tool if you are tired or under the influence of alcohol, drugs, or medications that could affect your ability to use the tool properly.

 **WARNING:** Dress properly. Do not wear loose clothing or jewelry as they can be caught in moving parts. Wear restrictive hair covering to contain long hair.

 **WARNING:** Do not reach over or across running machines. Keep proper footing and balance at all times. Non-skid footwear is recommended when working.

Air Tool Use and Care

 **WARNING:** Air under pressure can cause severe injury. Never point an air tool at anyone or direct air at yourself or others. It could cause serious injury.

 **WARNING:** Always turn off the air supply, drain the hose of air pressure and detach the tool from the air supply before installing, removing or adjusting any accessory on this tool, or before performing any maintenance on this tool. Failure to do so could result in injury.

 **WARNING:** Always check for damaged, frayed or loose hoses and fittings. Have any defective or damaged parts replaced immediately by qualified personnel.

 **WARNING:** Do not carry the tool by the hose. Protect the hose from sharp objects and heat.

 **WARNING:** Always use air hose and couplings with a minimum working pressure rating of at least 1-1/2 times the maximum working pressure rating of the tool.

 **WARNING:** Do not depress the tool trigger/lever when connecting the air supply hose.

 **WARNING:** Do not lock, tape, wire, or otherwise disable the "ON/OFF" valve in the "ON" position. The trigger must always be free to return to the "OFF" position when released.

 **WARNING:** When the tool is not in use, shut off the air supply and press the trigger/lever to drain the air supply line. If the tool is not to be used for a period of time, first lubricate, disconnect from the air supply and store in a clean and dry location at average room temperature.



NOTE:

Typical Air Supply Installation

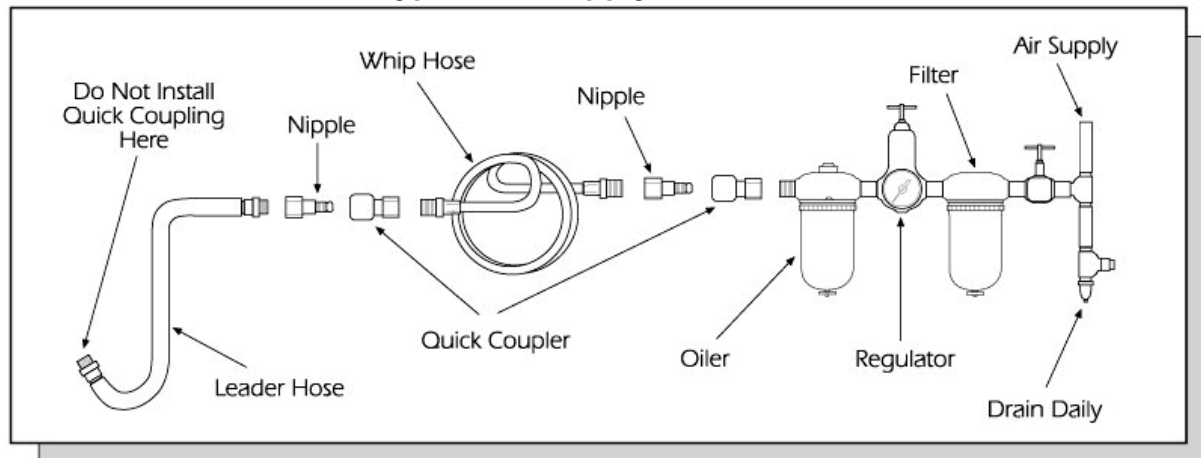

Always use clean, dry air. Dust, corrosive fumes and/or water in the airline will cause damage to the tool. Drain the air tank daily. Clean the air inlet filter screen on at least a weekly schedule. The recommended hook up procedure can be viewed in the above figure.

Lubricate the tool's air motor daily with quality air tool oil. If no airline oiler is used, run 1/2 oz. of oil through the tool. The oil can be squirted into the tool air inlet or into the hose at the nearest connection to the air supply, then run into the tool. Overfilling will cause a reduction in the power of the tool.

REPETITIVE MOTION / VIBRATION HAZARDS

⚠️ WARNING: Avoid prolonged exposure to vibration. Vibration, repetitive motions, or uncomfortable positions over extended periods of time may be harmful to your hands and arms. Do not ignore symptoms or persistent or recurring discomfort, pain, throbbing, aching, tingling, numbness, burning sensation, or stiffness. Discontinue use of the tool and seek medical advice before resuming use.

Operating Instructions

1. Before use, lubricate with air tool oil and run the tool slowly for 20 minutes. Lubricate regularly after each use, and at suggested intervals of 30 minutes during use to maintain tool life. An auto lubricator is recommended.
2. Check tool before each use, inspect that all parts are in good condition and operational before using your palm sander.
3. For best results and to prolong tool life, install a filter and a lubricator/oiler at the air inlet.
4. Recommended pressure during operation is from 10 lbf to 15 lbf (5kgf/cm³ to 7 kgf/cm³)
5. **ALWAYS** disconnect the air supply when replacing the sand paper or backing pad.
6. **ALWAYS** wear eye protection, dust mask and gloves during operation.
7. To avoid fatigue, take breaks periodically. 30 minute intervals are suggested.
8. **NEVER** let tool rotate freely (without load) at high speeds to avoid possible injury or tool damage.
9. **NEVER** touch the rotating part of the tool with hand or body during operation.
10. **ALWAYS** be sure that the sanding pad is attached flat on the surface of the backing pad before starting sanding job. (Refer to illustration 1).

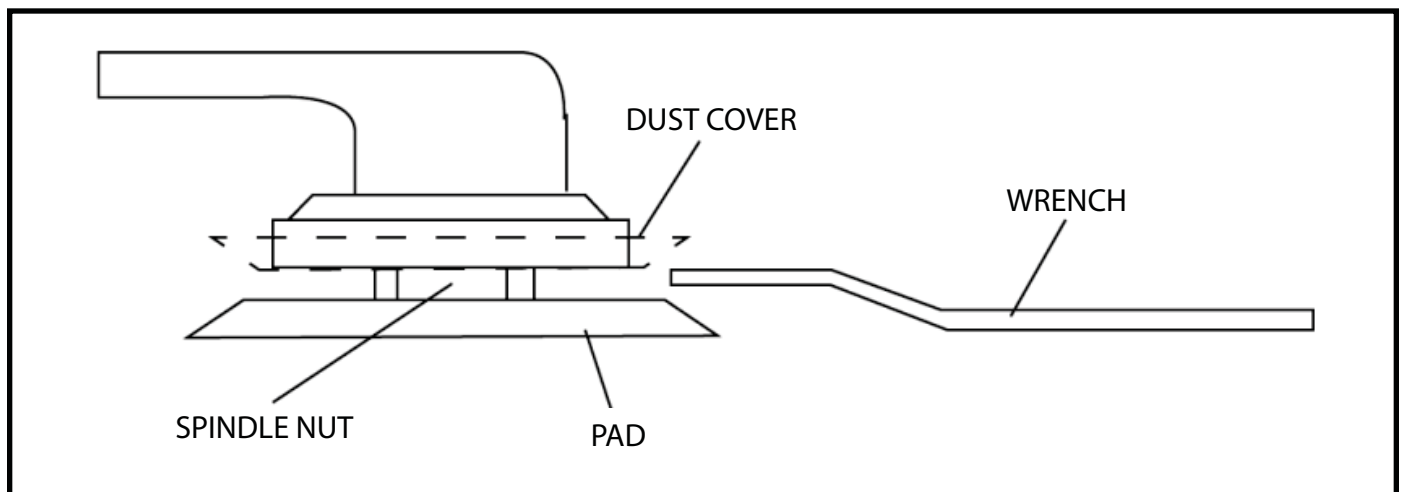

Illustration 1

11. If you notice any irregular sound or vibration during operation, **STOP USING THE TOOL IMMEDIATELY** and check and repair the tool before using again.
12. Be sure to use clean compressed air for operation. Use an in-line air filter with your air supply to clean impurities out of the compressed air.
13. Dirt inside the motor may result in slow rotation and less power of the tool. If this happens, first disassemble the regulator and press the trigger. Then drop 10-15 drops of air tool oil from the air inlet into the motor. Restart the motor within 30-40 minutes by re-fitting the air source and having the motor rotate at low speed for 1-2 minutes. **DO NOT USE GASOLINE, KEROSENE, OR ANY OTHER CAUSTIC CLEANERS** as they will damage your tool.
14. Drain the water out of your air compressor and air hose after each operation.

Removing The Sanding Disc

1. Pull back the dust cover (PRT2088-46) and insert the wrench (PRT2088-48) that was supplied with your sander between the dust cover and the sanding disc to hold the spindle securely. Note that the wrench has a slight bend in it. Insert it with the bend as shown in the diagram below for best results.
2. Loosen the pad by turning it counterclockwise (looking at it from the working surface) by hand. If you need extra turning power, perhaps put on a leather glove to grip the pad with while you turn it.





ATD AIR®
ATD-2088

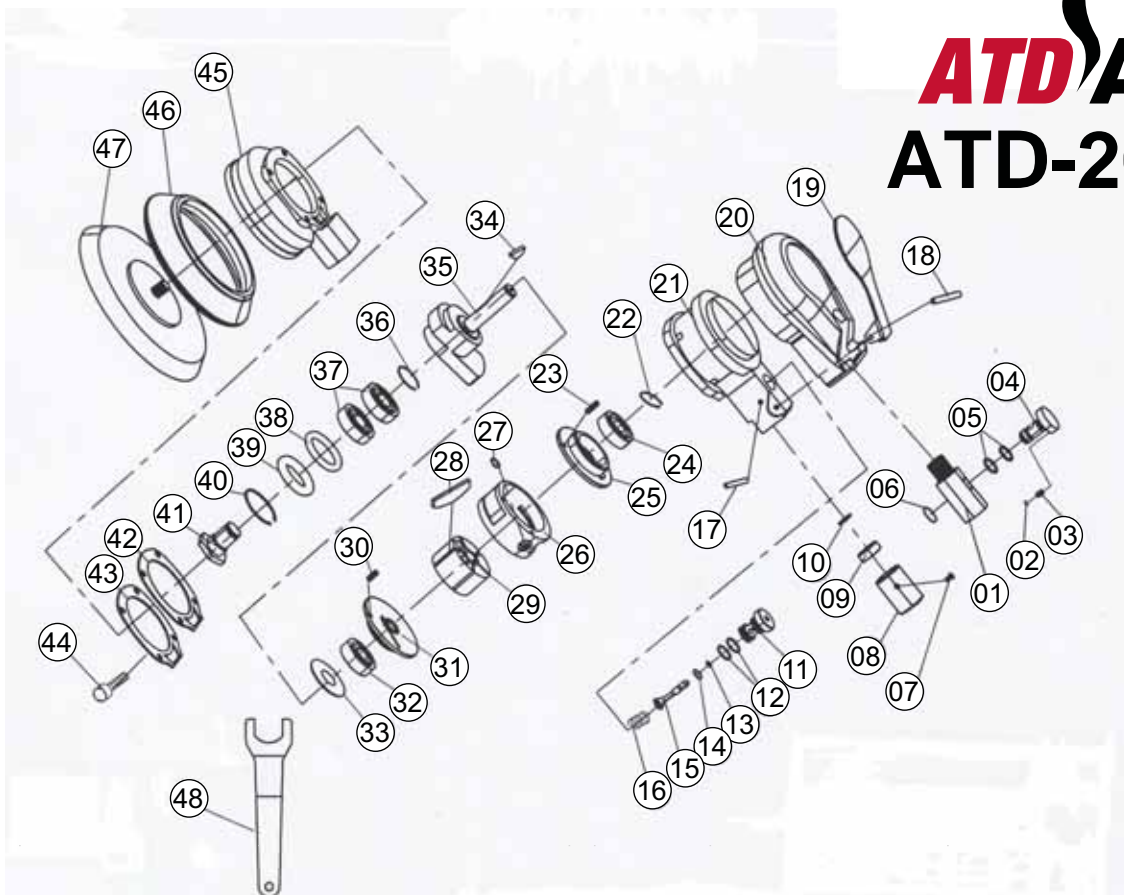

ITEM#	ORDERING PART#	PART DESCRIPTION
1	PRT2088-01	AIR STRAINER
2	PRT2088-02	DENTENT DW=3
3	PRT2088-03	DENTENT SPRING
4	PRT2088-04	REVERSE VALVE
5	PRT2088-05	O-RING 5.6x1.8
6	PRT2088-06	SNAP-RETAINER
7	PRT2088-07	SCREW M4x8
8	PRT2088-08	MUFFLER
9	PRT2088-09	MUFFLER CONNECTOR
10	PRT2088-10	O-RING 6.7x1.8
11	PRT2088-11	VALVE CORE
12	PRT2088-12	O-RING 8.5x1.8
13	PRT2088-13	O-RING 2x1.0
14	PRT2088-14	O-RING 4x1.5
15	PRT2088-15	VALVE STEM
16	PRT2088-16	VALVE SPRING
17	PRT2088-17	PIN 3x22
18	PRT2088-18	PIN 3x24
19	PRT2088-19	TRIGGER
20	PRT2088-20	GRIP
21	PRT2088-21	HOUSING
22	PRT2088-22N	RETAINER 10
23	PRT2088-24	PIN 3x14
24	PRT2088-25	BEARING 6000Z

ITEM#	ORDERING PART#	PART DESCRIPTION
25	PRT2088-26	REAR PLATE
26	PRT2088-27	CYLINDER
27	PRT2088-28	O-RING 6.7x1.8
28	PRT2088-30	VANE
29	PRT2088-29	ROTOR
30	PRT2088-32	PIN 3x7
31	PRT2088-31N	FRONT PLATE
32	PRT2088-33	BEARING 6000Z
33	PRT2088-34	WASHER
34	PRT2088-35	HALF ROUND SHAFT
35	PRT2088-36N	ANVIL
36	PRT2088-39	RETAINER 12
37	PRT2088-40	BEARING 6001Z
38	PRT2088-41	DUSTPROOF GASKET
39	PRT2088-42	BEARING TRAY
40	PRT2088-43	SPRING RETAINER
41	PRT2088-44	TILTING AXLE
42	PRT2088-45N-1	SEALING GASKET
43	PRT2088-45N-2	GASKET
44	PRT2088-47	HEX SCREW M4*12
45	PRT2088-48N	COVER
46	PRT2088-49N	DUST COVER
47	PRT2088-50	BACKING PAD
48	PRT2088-51N	WRENCH

ALSO AVAILABLE:

PRT2088-SK - SERVICE KIT - INCLUDES ITEMS 02, 03, 05, 06, 10, 12, 13, 14, 22, 24, 28(x5), 32, 42 & 43

Learn more about air Sanders and polishers we have.