



Model:

# 3026

Product Type:

## 12V CORDLESS VARIABLE SPEED PALM POLISHER W/ 2 BATTERIES



### WARNING



Study, understand and follow all instructions provided with this product. Read these instructions carefully before installing, operating, servicing or repairing this tool. Keep these instructions in a safe accessible place.



## Astro Pneumatic Tool Company

### INTENDED USE OF THE TOOL

The 3026 was designed for wax, sealer, and glaze on automotive and marine painted surfaces. Only use the included batteries and charger. Do not use this tool outside of the designed intent. Never modify the tool for any other purpose or use.

### PRODUCT INFORMATION

- Fully adjustable 2500-5000 OPM motor, perfect for waxes, sealants and glazes
- 6" backing pad works with most 6" and some 5" hook and loop foam pads, includes black foam waxing and finishing pad
- Powerful 12V motor with two 2.0Ah 1hr quick charge batteries for minimal downtime
- 5mm random orbit DA ensures a uniform finish, safe even for beginners on all painted surfaces
- Lightweight with superior running balance for low fatigue after extended use



### WARNING



#### Caution: To help prevent personal injury

- **Use of this product can expose you to chemicals including ethylene glycol, gasoline vapors and engine exhaust, which are known to the State of California to cause cancer, birth defects, or reproductive harm. Always wear ANSI approved safety equipment, safety glasses and clothing when using this product. Study, understand, and follow all instructions provided with this product. Failure to read and follow all warnings and operating instructions may result in damages and serious injury or death.**
- Always wear ANSI approved goggles when using this product. (Users and By standers).
- Never use this tool for any application other than for which it was designed.
- Only use accessories designed for this tool.
- Never alter or modify this tool in any way.
- Improper operation and/or maintenance of the tool, modification of the tool, or use of the tool with accessories not designed for it could result in serious injury or death.
- Always select the correct accessories of the correct size and design for the job that you are attempting to perform.
- Always work in a clean, safe, well-lit, organized and adequately equipped area.
- Do not begin repairs without assurance that vehicle is in secure position, and will not move during repair.

*Specification:*

Battery cell: 2 x 12V 2.0Ah  
 Speed: 2500 - 5000 orbit per min, 6 settings  
 Orbit: 5mm  
 Charging time: 1 hour  
 Charge current: 12V 2.4A  
 Run time: 35 - 40 mins  
 Pad size: 6" hook and loop

### BEFORE USE

When unpacking, check the parts diagram and part number listing on page 4 to make sure all parts are included. If any parts are missing or damaged, please call your distributor.

### DO NOT DISCARD – GIVE TO USER



Model:

# 3026

Product Type:

## 12V CORDLESS VARIABLE SPEED PALM POLISHER W/ 2 BATTERIES

### INTRODUCTION



The operating instructions constitute part of this product. They contain important information on safety, use and disposal. Before using the product, familiarize yourself with all of the operating and safety instructions. Use the product only as described and for the applications specified.



Please keep this manual safe and in the event that the product is passed on, hand over all documents to the third party.

### SAFETY GUIDELINES

#### ⚠ WARNING:

Read and understand the manual instructions. Failure to follow all instructions listed below may result in electric shock, fire and/or serious personal injury.

#### WORK AREA

1. Keep your work area clean and well lit.
2. Do not operate power tools in explosive atmospheres, such as in the presence of flammable liquids, gases, or dust. Power tools create sparks which may ignite the dust or fumes.
3. Keep bystanders, children, and visitors away while operating a power tool. Protect others in the work area from debris such as chips and sparks. Provide barriers or shields as needed.

#### PERSONAL SAFETY

1. Stay alert. Pay attention to the power tool when operating it. Do not use a power tool while tired or under the influence of drugs, alcohol, or medication. A moment of inattention while operating power tools may result in serious personal injury.
2. Dress properly. Do not wear loose clothing or jewelry. Keep your hair, clothing, and gloves away from moving parts. Loose clothes, jewelry, or long hair can be caught in moving parts.
3. Avoid accidental starting. Make sure the switch is in the locked off position before inserting battery pack.
4. Use safety equipment. Always wear eye protection. Dust mask, non-skid safety shoes, hard hat, or hearing protection must be used for appropriate conditions.

#### TOOL USE AND CARE

1. Do not force tool. Use the correct tool for your application. The correct tool will do the job better and safer at the rate for which it is designed.
2. Do not use the tool if switch does not function reliably or if switch is nonfunctional. A tool that cannot be controlled with the switch is dangerous and must be repaired.
3. Disconnect the battery pack from the tool or place the switch in the locked off position before starting the tool to ensure no accidental starting.

4. Store idle tools out of reach of children and other untrained persons. Tools are dangerous in the hand of untrained persons.
5. When battery pack is not in use, keep it away from other metal objects that can make a connection from one terminal to another. Shorting the battery terminals together may cause sparks, burns or a fire.
6. Check for misalignment or binding of moving parts, broken parts, and any other conditions that may affect the tool's operation.
7. Use only accessories that are recommend by the manufacturer for your model.

#### SERVICE

1. Tool service must be performed only by qualified repair personnel. Service or maintenance performed by unqualified personnel may result in a risk of injury.
2. Accessories must be rated for at least the speed recommended on the tool warning label.

#### IMPORTANT:

Do not operate the polisher until you have inspected each part. If any part is missing or damaged, do not use it. Return the polisher to the place of purchase.

#### ENVIRONMENTALLY SAFE DISPOSAL OF YOUR BATTERIES

#### BATTERY SAFETY RULES

1. Do not attempt to open any battery.
2. Do not put the batteries in the regular trash.
3. Do not incinerate any battery.
4. If a leak appears, the released electrolytes are corrosive, wash your hands and do not get the material in your eyes or mouth.
5. Dispose your batteries to a certified disposal center.
6. The battery pack not in use shall be far from other metal objects such as paper clips, coins, keys, nails, screws or other small metal objects that may cause an electrical short. The short of the one terminal may cause sparks, burn and even a fire.
7. The battery pack can only be charged by the charger supplied in this kit, other types may burst causing fire or other danger.



Model:

**3026**

Product Type:

**12V CORDLESS VARIABLE SPEED  
PALM POLISHER W/ 2 BATTERIES**

8. Only the battery pack supplied in this kit can be used for the polisher. Other types may cause fire or other dangers.
9. Do not store the battery pack in a container with other metal objects such as nails, coins, etc.
10. Do not short the battery pack, a battery short can cause a large current flow, overheating, possible burn and even a fire.
11. Do not expose the battery pack to water or rain.
12. Do not carry the battery pack in a pocket containing any metal objects.
13. Do not store the battery pack in locations where the temperature may reach or exceed 50°C (182°F).
14. Do not incinerate the battery pack even if it is severely damaged or is completely worn out.
15. If batteries leak, avoid contact with the liquid. Should contact occur, wash immediately with soap and water.
16. Make sure the switch is in the off position before inserting the battery pack into the polisher to avoid damages caused by accidental starting.

## **BATTERIES AND BATTERY CHARGER**

1. Unplug your battery charger when you are not charging your batteries.
2. If your battery pack is hot, let it cool before recharging.
3. Do not charge batteries in direct sunlight.
4. Keep your battery charger clean, and while unplugged wipe out the cavity with a dry cloth, never use water or solvents.

## **CHARGING THE BATTERY**

### **⚠ CAUTION**

Charge only the 12 volt battery with your charger supplied in this kit, other types may burst causing damage or personal injury. Your new battery pack is not fully charged when received; therefore, charging is necessary prior to use.

1. Plug the charger into a 120 V power source and insert the battery pack into the charger receptacle pocket. Make sure that the polarity rib in the battery pack is aligned with the polarity slot in the charger. There are plus and minus symbols on either side of the battery pack that designate the polarity of the terminals. These symbols are on the same sides as their respective symbols on your charger. In order for the charger to work properly the pack must be fully inserted into the charger receptacle pocket. When fully inserted into the pocket a light will come on.
2. Use only (120 volts, 60HZ AC only) regular household voltage.
3. Do not attempt to use a step-up transformer, an engine generator or DC power receptacle.
4. Do not allow anything to cover or clog the charger vents.
5. Before connecting the charger to a power source, be certain the voltage supplied is the same as power requirement specified on the charger. Mismatched voltage source can result in serious injury to the user. When in doubt, don't plug in the charger.
6. Do not operate charger if damaged in any way. Do not operate the charger with a damaged cord. Return charger to the place of purchase. To prevent damage to the cord when disconnecting charger from power source, grip plug body when removing it from a receptacle.
7. Unplug charger from outlet before attempting maintenance or cleaning.
8. When not in use with a battery pack, the battery can be connected with the charger (indicated by the red light) without any adverse effect; the batteries can't be "over-charged". However, if the battery pack is not going to be used for an extended period time, the charger should be unplugged from its power source.



Model:

# 3026

Product Type:

## 12V CORDLESS VARIABLE SPEED PALM POLISHER W/ 2 BATTERIES

### DESCRIPTION

6" cordless polisher, DC 12V, 2.0Ah, orbital design, direct drive.  
Ideal for autos, SUVs, boats, airplanes and other coated finishes.

### OPERATING INSTRUCTIONS

1. Place a clean Foam Pad securely onto the EVA Plate.
2. Prior to waxing/polishing a vehicle, make sure its surface has been thoroughly cleaned and is free of dust, dirt, oil, grease, etc. And waxing should not be performed in direct sunlight or (obviously) rain.
3. Start with around 3-4 pea-sized dollops of liquid wax around the circumference of the wax pad. Do not apply the wax directly to the surface of the vehicle. The amount of wax needed will vary according to the size of the vehicle being waxed. NOTE: Avoid using too much wax.
4. Grip the Polisher firmly with both hands. Make sure the pad with wax on it is in contact with the vehicle's paint BEFORE you turn the polisher on, or the centripetal force of the spinning polisher will fling product off the pad and all over you and your workspace. Then turn the Power Switch to its "ON" position and control the pad speed with the speed selector switch positions 1-6.
5. Begin applying wax to the vehicle. Apply the wax to all flat surfaces with broad, sweeping strokes in a 2' x 2' area of paint at a time. Apply the wax evenly over the surface of the vehicle, and add additional wax as needed.
6. You'll need to turn the machine off when adding wax to the pad as well. Remove the Foam Pad. With the Foam pad in your hand apply the wax to all hard to reach areas of the vehicle such as around lights, door handles, under bumpers, etc.
7. Allow sufficient time for the wax to dry on the vehicle, the drying time is heavily dependent on ambient temp, humidity or wax manufacture recommendations.

### PARTS BREAKDOWN

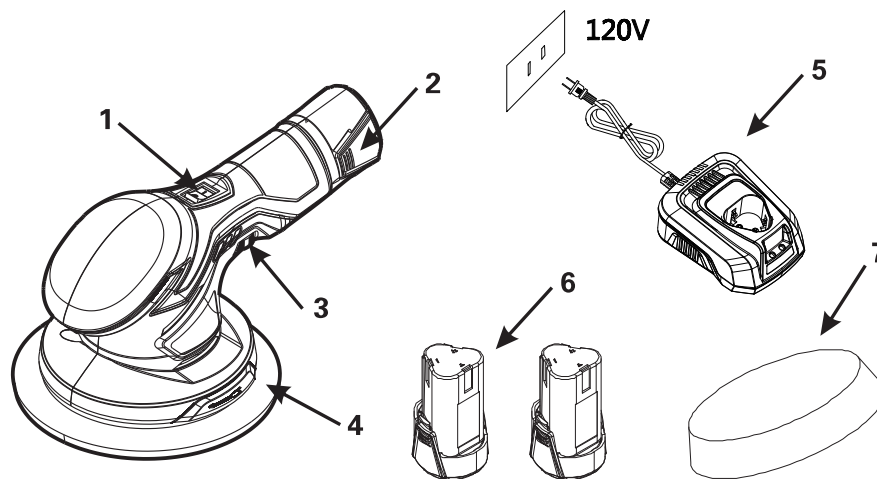

#### Parts List

Index	Part No.	Description	Qty
1		Switch Button	
2		12V Lithium Battery	
3		Speed Control: 1-6 Level	
4	3026-04	6" backing pad	1
5	3026-05	Battery Charger	1
6	3026-06	Battery	2
7	3026-07	6" Foam Pad	1