



Model:

1832

Product Type:

ONYX 1/2" NANO ANGLE IMPACT WRENCH - 415FT/LB



WARNING



Study, understand and follow all instructions provided with this product. Read these instructions carefully before installing, operating, servicing or repairing this tool. Keep these instructions in a safe accessible place.

INTENDED USE OF THE TOOL

The 1832 is intended to be used for removing and fastening bolts and nuts with 1/2" drive impact sockets only. Do not use this tool outside of the designed intent. Never modify this tool for any other purpose or use.

⚠ WARNING ⚠

Caution: To help prevent personal injury.

- Use of this product can expose you to chemicals including ethylene glycol, gasoline vapors and engine exhaust, which are known to the State of California to cause cancer, birth defects, or reproductive harm. Always wear ANSI approved safety equipment, safety glasses and clothing when using this product. Study, understand, and follow all instructions provided with this product. Failure to read and follow all warnings and operating instructions may result in damages and serious injury or death.
- Always wear ANSI approved goggles when using this product. (Users and Bystanders).
- Never use this tool for any application other than for which it was designed.
- Only use accessories designed for this tool.
- Never alter or modify this tool in any way.
- Improper operation and/or maintenance of the tool, modification of the tool, or use of the tool with accessories not designed for it could result in serious injury or death.
- Always select the correct accessories of the correct size and design for the job that you are attempting to perform.
- Always work in a clean, safe, well-lit, organized and adequately equipped area.
- Do not begin repairs without assurance that vehicle is in secure position, and will not move during repair.

ONYX 1/2" NANO ANGLE IMPACT WRENCH - 415FT/LB



MADE IN TAIWAN

DO NOT DISCARD – GIVE TO USER



Astro Pneumatic Tool Company



BEFORE USE

Before use, check the parts diagram and part number listing on page 4 to make sure all parts are included. If any parts are missing or damaged, please call your distributor.

PRODUCT INFORMATION:

- Shorter than a credit card at 3.46" long
- Industry leading 415 ft/lbs. of MAX torque

SPECIFICATIONS:

Square Drive: 1/2"	Weight: 2.78 lbs
Handle Type: Straight right angle	Length(from end to end): 3.46"
Clutch type: Oversized Hammer	Height(from end to end): 10.4"
Motor Housing: Aluminum w/ bed liner finish	Free Speed: 9000 r.p.m.
Air Exhaust: 360° Swivel Air Muffler	Noise Level(sound pressure): 85 dB
Air Inlet Thread: 1/4" NPT	Average Air Consumption: 4.2 CFM
Switch: 3-speeds in both F and R	Min. Hose Size: 3/8"
Max Torque: 415 ft/lbs	
Working Torque: 300 ft/lbs	



Model:

1832

Product Type:

ONYX 1/2" NANO ANGLE IMPACT WRENCH - 415FT/LB

MAINTENANCE INSTRUCTION:

1.) LUBRICATION:

Before connection of the hose, apply 4 to 5 drops of a good quality air tool oil at the air inlet. After 3 to 4 hours of operation, oiling may be necessary again.

2.) TIGHTNESS OF PARTS:

Regularly check whether all connection parts are **fastened securely**. **Follow this procedure daily before beginning work.**

3.) STORAGE:

Avoid storing the tool in a location subject to high humidity. If the tool is left unused, the residual moisture inside the tool can cause rust. Before storing and after operation, oil the tool at the air inlet with a good quality air tool oil and run it for a short period.

4.) DISPOSAL:

Follow national legislation of waste disposal.

Users of this tool should review the chemical composition of the work surface and any products used in conjunction with this tool for any such chemicals prior to engaging in any activity that creates dust and/or microscopic particles.

Users should obtain the Material Safety Data Sheets for all identified chemicals, either from the manufacturer or their employer, and proceed to study, understand, and follow all instructions and warnings for exposure to such chemicals.

Some examples of these chemicals are: lead from lead based paints; crystalline silica from bricks, cement and other masonry products; and arsenic and chromium from chemically treated lumber.

In order to reduce their exposure to such chemicals, users should always:

- work in well-ventilated areas.
- wear appropriate safety equipment and clothes that are specifically designed to filter out microscopic particles.



WARNING



1. The tool shall not be used in potentially explosive atmospheres.
2. Disconnect the air hose before changing or adjusting any inserted tools.
3. Before using tool, please confirm all couplings and plugs are fixed securely. An air hose that is under pressure may lash out when disconnected and could lead to serious injuries.
4. Prevent loose clothes, long hair or any other personal accessories from coming close to moving parts to reduce the risk of being caught, trapped or drawn into the operation.
5. Excessive high air pressure that exceeds the maximum pressure may cause injuries to user.
6. Exposure to strong vibration for extended time may cause harm to operator.
7. **WATCH YOUR STEP!** Leaving excess hose unattended near working area or walk path could result in injury or death.
8. Wearing eye/face protection could reduce the danger to person from high speed splinters being emitted from the tool or work surface.
9. Wearing correct breathing protection will help avoid inhaling dust or debris from work process that can be harmful to your health.
10. High sound levels can cause permanent hearing loss. Use hearing protection while operating tool.



Model:

1832

Product Type:

ONYX 1/2" NANO ANGLE IMPACT WRENCH - 415FT/LB

The oil and water extractor should not be mounted on or near the air compressor.

The temperature of air is greatly increased during compression. As the air cools down to room temperature, in the air line, on its way to the Air Power Tool, the moisture contained in it condenses. Thus, for maximum effectiveness, the oil and water extractor should be mounted at some point in the air supply system where the temperature of the compressed air in the line is likely to be lowest. Air lines must be properly drained daily. Each low point in an air line acts as a water trap. Such points should be fitted with an easily accessible drain. See diagram below. Pitch all air lines back towards the compressor so that condensed moisture will flow back into the air receiver where it can be drained off. Drain daily.

SUGGESTED AIR LINE CONNECTION

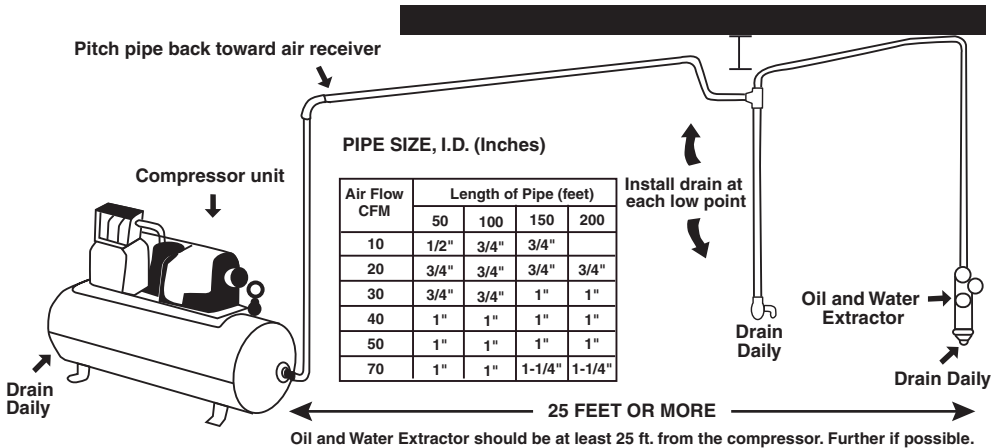



**Astro Pneumatic
Tool Company**

Model:

1832

Product Type:

**ONYX 1/2" NANO ANGLE
IMPACT WRENCH - 415FT/LB**

PARTS BREAKDOWN

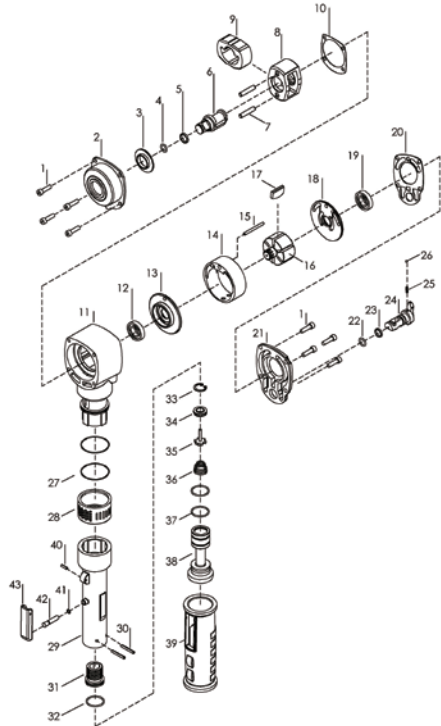

Parts List

Index	Part No.	Description	Qty
1	1832-01	Socket Cap Screw W/Washer	8
2	1832-02	Hammer Housing	1
3	1822-03	Hammer Case Bushing	1
4	1822-05	O-Ring	1
5	1822-04	Retainer Ring	1
6	1832-06	Drive Anvil	1
7	1832-07	Hammer Pin	2
8	1832-08	Hammer Cage	1
9	1832-09	Hammer Cam	1
10	1822-10	Hammer Housing Gasket	1
11	1832-11	Housing	1
12	1822-18	Ball Bearing R8	1
13	1822-19	Front End Plate	1
14	1822-20	Cylinder	1
15	1822-21	Dowel liner	1
16	1822-22	Rotor	1
17	1822-23	Rotor Blade	6
18	1822-24	Rear End Plate	1
19	1822-25	Ball Bearing R8	1
20	1822-26	Motor Housing Gasket	1
21	1822-27	Housing Cap	1
22	1822-28	O-Ring	1
23	1822-29	E-Ring	1
24	1822-30	Regulator Knob	1
25	1822-31	Regulator Valve Detent Spring	1
26	1822-32	Regulator Valve Detent Ball	1
27	1832-27	O-Ring	2
28	1832-28	Air Exhaust Deflector	1

Index	Part No.	Description	Qty
29	1832-29	Handle	1
30	1832-30	Spring Pin	2
31	1832-31	Conjunction Screw	1
32	1832-32	O-Ring	1
33	1832-33	Retainer Ring	1
34	1832-34	Throttle Bushing	1
35	1832-35	Throttle Valve	1
36	1832-36	Throttle Spring	1
37	1832-37	O-Ring	2
38	1832-38	Air Inlet Bushing	1
39	1832-39	Handle Grip	1
40	1832-40	Spring Pin	1
41	1832-41	O-Ring	1
42	1832-42	Trigger Valve	1
43	1832-43	Trigger	1