





50 Ton SD Shop Press Operating Guide

MODEL NO. 854SD

Hazard Symbols Used in the Manuals

This manual includes the hazard symbols defined below when the operations or maintenance job involves a potential danger. These symbols describe the level of danger involved in performing a job on the tool and the precautions to take to avoid the hazard.

Term	Sign	Description
Danger Label		Danger Labels indicate an imminently hazardous situation that if not avoided, WILL result in death or serious injury.
Warning Label		Warning Labels indicate a potentially hazardous situation, which if not avoided, COULD result in death or serious injury.
Caution Label		Caution Labels indicate a potentially hazardous situation, which if not avoided, MAY result in minor or moderate injury.
Note	NOTE:	Short piece of additional information with the purpose of adding or emphasizing important points in the text.

Safety Requirements

Important

Make sure to read, understand, and strictly follow all safety related instructions before operation or maintenance of this equipment.

Intended Users

This manual is to be made available to all persons who are required to install, configure or service equipment described herein, or any other associated operation.

Application Area

The machinery described is intended for machinery production and assembling spare parts. It is used to press, size, assemble, rivet small parts in process and not for other use.

Personnel

Installation, operation and maintenance of the equipment should be carried out by qualified personnel. A qualified person is someone who is technically competent and familiar with all safety information and established safety practices with the installation process, operation and maintenance of this equipment; and with all the hazards involved.



Hazards

Personnel safety must have top priority. Thoroughly read the operation manuals to completely understand proper procedures before maintenance or inspection work.



Basic Safety Instructions

Failure to comply with the following could result in serious injury or death.

IMPORTANT

This press is shipped with a removable Guard, determine if the included guard is appropriate for the application, due to the wide variety of pressing / bending applications, it is impossible to incorporate one guard that will apply to all applications. ALWAYS ENSURE THAT THE OPERATOR AND BYSTANDERS ARE PROPERLY GUARDED FROM THE POSSIBILITY OF FLYING DEBRIS.

1. Periodic inspections or maintenance work must be carried out by two or more persons.
2. Read and understand the safety manual.
3. Read and understand all the attached manuals.
4. Attach visible signs on the equipment so that everyone recognizes and understands that maintenance or inspection is ongoing.
5. Post a list with emergency phone numbers nearby the working area.
6. Operator should be aware of what to do in case of an emergency (refer to the Procedures for Emergency Situations); know the location of the first-aid-kit, and the location of the fire extinguisher. Also learn how to use a fire extinguisher.
7. Alert anyone around the Tool whenever planning to operate it during maintenance or inspection work.
8. Always use proper hand tools and jigs during maintenance or inspections. Before operating the machine, check for any hand tools or jigs left inside it. For your own safety, **NEVER** try to remove them with the machine under operation. Consider **SAFETY FIRST**.
9. The operator must wear protective clothes, gloves, safety helmet, shoes and ear protection during operation.
10. To prevent back injury, heavy parts (or units) must be moved by two or more persons.
11. Before powering the machine, alert the persons around it.
12. Be careful not to be pinched by moving parts.
13. Use **ONLY CARRIER** specified for the tool, and set it in a correct position.
14. To avoid accidents, always be aware of any on-going work on the machine. Also, always stay focused on the job to be done.



Safety Instruction and Warnings

1. Before maintenance on pressured parts in the machine, you **MUST** release the pressure in the pressured system. At the same time, **DO NOT** stand in the direction facing the charger, the operator should be on the opposite side and remember **DO NOT** strike, press or transfer until it is discharged.
2. When it is necessary to exchange die after running, operators should wear glove or use tools to operate avoid being hurt.

NOTE:

Immediately stop operating the equipment if not working properly. Contact certified technical support engineers for repair. The equipment must not be operated without approval from the certified technical support engineer.



Prohibited Dangerous Actions

This section describes examples of dangerous actions not only during equipment operation, but also during maintenance and inspections. To avoid accidents, thoroughly read and understand the instructions below regarding dangers related to each mechanism prior to any maintenance or inspection work.

1. Use a qualified person to keep the lift in good condition. Keep it clean for best and safest performance.
2. The maximum load is 50 Ton. **DO NOT** exceed this rated capacity. Never apply excessive force to a work piece and always use the pressure gauge to accurately determine the applied load. Burst hazard exists if hose or connection pressure exceeds rated pressure.
3. Shop presses are designed for automotive, truck, implement, fleet, and industrial repair shops where pressing, bending, straightening, forming or holding is required. Each press includes a cylinder, a pump, and lifting bar which provides a safe way to raise and lower the bed frame, and a pressure gauge for monitoring the applied press force.
4. Keep children and unauthorized persons away from the work area.
5. Remove loose fitting clothing. Remove ties, watches, rings and other loose jewelry, and contain long hair.
6. Wear ANSI approved impact safety goggles, full-face impact safety shield and heavy-duty work gloves when operating the press.
7. Keep proper balance and footing, wear nonskid footwear and do not overreach.
8. Only use this press on a surface that is stable, level, dry and not slippery, and capable of sustaining the load. Keep the surface clean, tidy and free from unrelated materials and ensure there is adequate lighting.
9. Inspect the press before each use. Do not use if bent, broken, cracked, leaking or otherwise damaged, any suspect parts are noted or it has been subjected to a shock load.
10. Check to ensure that all applicable bolts and nuts are firmly tightened.
11. Ensure that work piece is center-loaded and secure.
12. Keep hands and feet away from bed area at all times.
13. Do not use the shop press to compress spring or any other item that could disengage and cause a potential hazard. Never stand directly in front of loaded press and never leave loaded press unattended.
14. Do not operate the press when you are tired or under the influence of alcohol, drugs or any intoxicating medication.
15. Do not allow untrained persons to operate the press.
16. Do not make any modifications to the press.
17. Do not use brake fluid or any other improper fluid and avoid mixing different types of oil when adding hydraulic oil. Only good quality hydraulic jack oil can be used.
18. Do not expose the press to rain or any other kind of bad weather.
19. If the press needs repairing and/or there are parts that need to be replaced, have it repaired by authorized technicians and only use the replacement parts supplied by the manufacturer.

WARNING: The warnings, cautions and instructions discussed in this instruction manual cannot cover all possible conditions and situations that may occur. It must be understood by the operator that common sense and caution are factors which cannot be built into this product, but must be supplied by the operator.

Environmental Pollution









If the substances you use come under the ordinances concerning environmental pollution, follow the ordinances to discharge and dispose of such substances. If you commission industrial waste companies, you should confirm the way of final processing.



Check for the safety of people working around the Tool, before powering it.

Warning Label

Drawings below show warning labels attached to the machine.

1		Hand crush force from above
2		Read operator's manual
3		Consult technical manual for proper service procedures
4		Must wear protective clothes
5		Must wear protective gloves
6		Must wear safety helmet
7		Must wear protective shoes
8		Must wear ear protector



Application Area

The machinery described is intended for machinery production and assembling spare parts. It is used to press, size, assemble, rivet small parts in process and not for other use.

2.4 Technical Capacity

No.	Item		Unit	Value
1	Capacity		Ton	50
2	Stroke		mm	200
3	Pressure of Hydraulic System		MPa	62.42
4	Working Range		mm	62~1042
5	Air Inert Fitting		NPT	1/4"
6	Air Pressure		MPa	0.75-0.85
7	Bed Size	Width	mm	259
8	Speed		mm/s	1.2
9	Height above floor		mm	1920
10	Covered area	Width	mm	1090
		Length	mm	1360
11	Gross weight		Kg	365

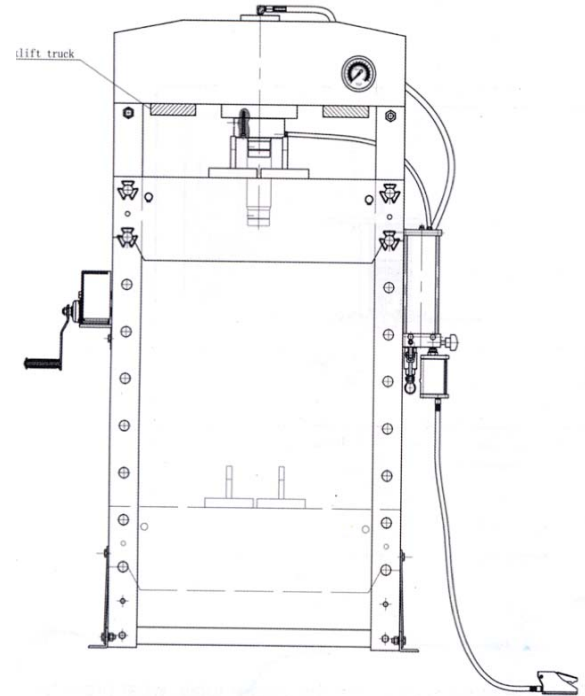

Prepare before using

The units are generally too heavy to be moved by hand. Therefore, use the correct transport and lifting equipment. The weights and dimensions of this press are shown in the chart above. When moving the machine, please use the proper lifting equipment and follow the instructions as follows.

Working Area Conditions

Users should provide enough space for the equipment and the environment should be clean, non-flammable, corrosive and dust free.



A working area of 10m is to be kept free both in front of and behind the machine while it is in operation so that it is always easily accessible.



Unpacking

When open the packing, please make sure to use the proper tools, wear protective clothing, gloves, safety helmet. Make sure that the product and parts in box should be complete and identical with the part list. If not, please contact with the manufacturer in time.

Disposal of the packaging

The packaging of these machines consists of PVC film and polywood case. The proper disposal of the packaging is the responsibility of the customer.



Installation



The machine must only be installed and commissioned by qualified personnel!
All relevant safety regulations must be strictly adhered to!

- The bed frame (23) is at the bottom in for convenient for packaging and transport, then fixed on the post (10) by two bolts M12. (figure 1)
- **Attach the foot section (01) and support (03) to left and right connecting plate (30) using bolt (02), washer (06), lock washer (05) and nut (04).** (figure 2)
- Remove Gauge Plug (22), insert Nylon Ring (42) into Gauge Fitting (43) and thread in Pressure Gauge (41) until tight. Ensure entire assembly is tight or it may leak. (figure 3, 4)
- Move the Pump Assembly (15) to the outside of the leg (32), use bolt (47) and (washer) to reconnect the pump assembly and tighten. (figure 5)
- Move the hand winch (11) to the outside of the post, then use bolt (02), washer (06), lock washer (05), and nut (04) which were dismantled just now to reattach to connecting plate (34).

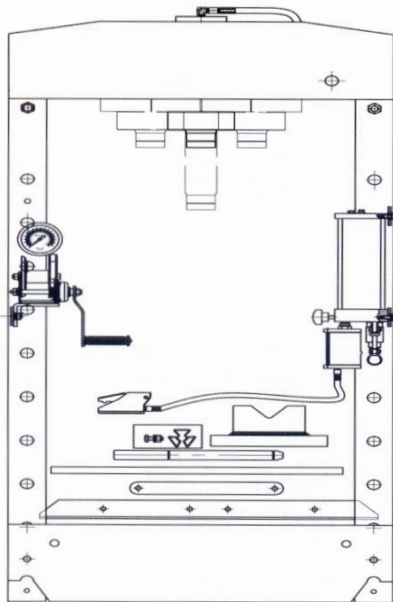

Figure 1

ASSEMBLY

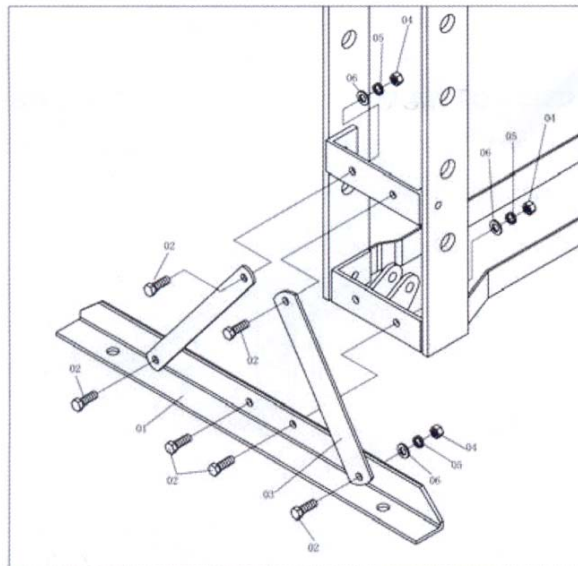

Figure 2

GAUGE ASSEMBLY

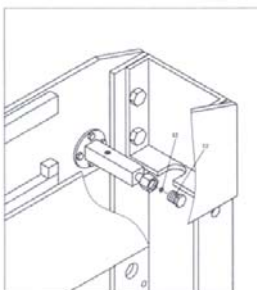

Figure 3

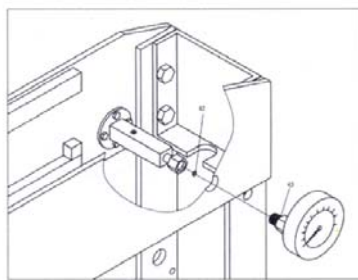

Figure 4

PUMP ASSEMBLY

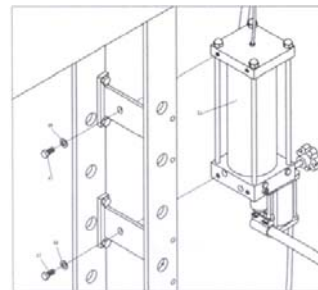
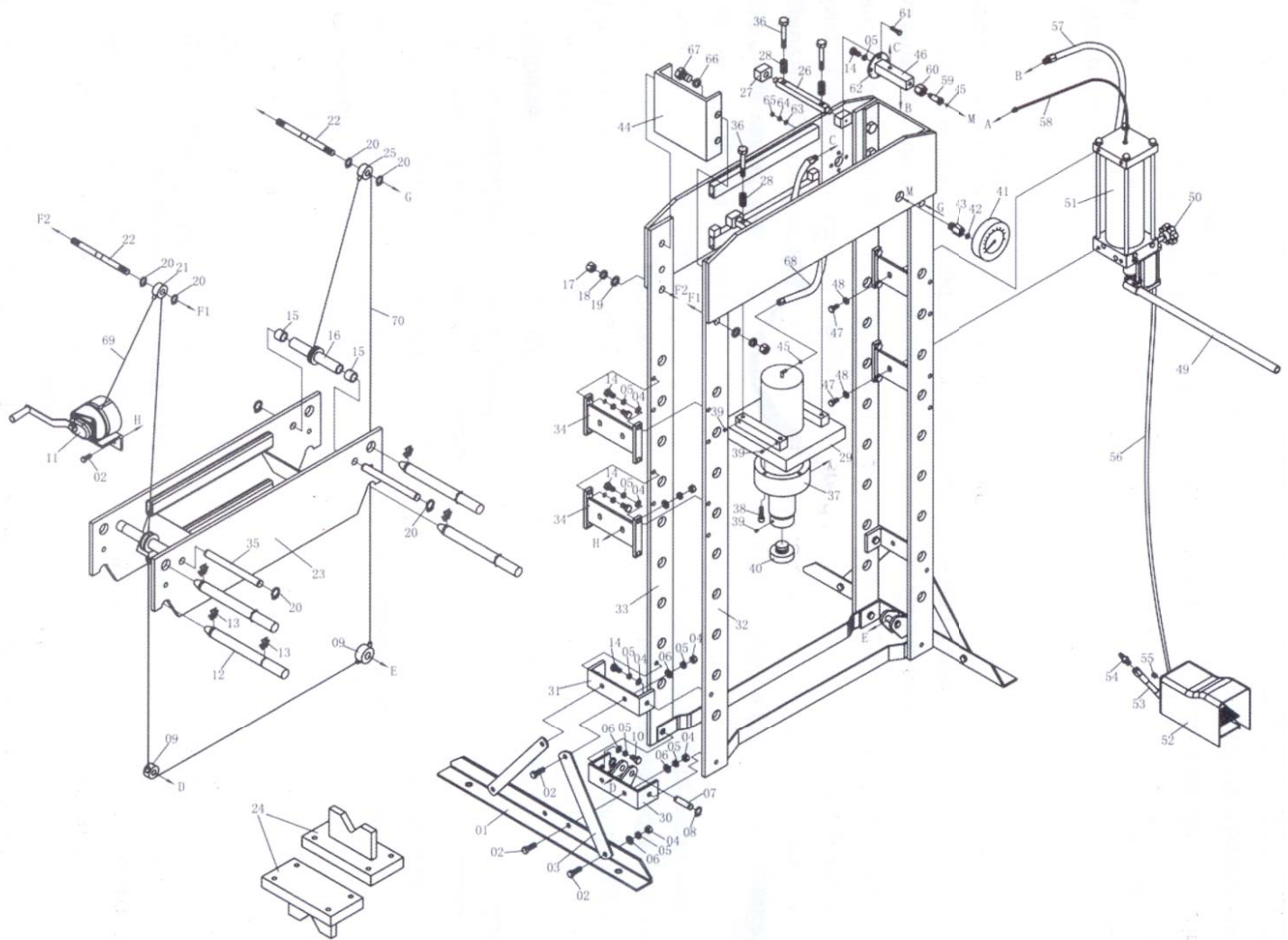

Figure 5



Exploded Drawing



Prior to first use **CAUTION**

- Before the first use, fix the machine to the floor by anchor bole. Ensure the standing surface of the machine site is firm and horizontal, and that sufficient lighting is provided.
- Clean the machine thoroughly. Before first use of this product, pour a teaspoon of good quality, air tool lubricant into the air supply inlet of the lift control valve, connect to air supply and operate for 3 seconds to evenly distribute lubricant.



IMPORTANT

This press is shipped with a removable Guard, determine if the included guard is appropriate for the application, due to the wide variety of pressing / bending applications, it is impossible to incorporate one guard that will apply to all applications. **ALWAYS ENSURE THAT THE OPERATOR AND BYSTANDERS ARE PROPERLY GUARDED FROM THE POSSIBILITY OF FLYING DEBRIS.**

AIR PURGE from the hydraulic system.

- Manual operation system: open the release valve (50) by turning it counterclockwise. Pump handle (49) several full strokes to eliminate any air in the system.
- Air operating system: open the release valve (50) by turning it counterclockwise. Connect the air supply hose to the Foot Operated Control Valve (52), depress the Foot Operated Control Valve (52) letting the pump work for several times to eliminate any air in the system.
- Check all parts and conditions, if there is any part broken, stop using it and contact your supplier immediately.



This press is shipped with a Pressing Adapter Set, which includes various size and capacity Pressing Adapters – **EACH ADAPTER HAS A MAXIMUM CAPACITY BASED ON ITS SIZE – DO NOT USE ADAPTER BEYOND RATED CAPACITY.**

Operation

Ensure bed frame is at proper position and insert Press Bed Pins (12) fully through the Press Bed and Legs and lock in place using the Circlip (13).

1. Close the release valve (50) by turning it clockwise until it is firmly closed.
2. **AIR OPERATION:** Connect the Foot Operated Air Valve (52) to air source, depress the Foot Control (52) to let the pump work until Serrated Saddle (40) nears work piece, release air valve.

IMPORTANT: Ensure the Press Bed (23) is fully supported by all four of the Press Bed Pins (12)

Place the heel block (24) on bed frame (23), then insert work piece onto the heel block.

- **Note: The steel block must be used in pairs, not individually.**
- **The steel block can be used by both sides.**

3. **MANUAL OPERATION:** Pump the Handle (49) until Serrated Saddle (40) nears work piece.
4. Align work piece and ram to ensure center loading.
5. Slowly apply load to work piece observing Pressure Gauge (41) to avoid over pressurizing work piece.
6. For more precise pressure control it may be advisable to use the Handle (49) to apply pressure slowly instead of the Air Motor.
7. When finished, release pressure by turning Release Valve (50) slowly counterclockwise no more than 1 ½ to 2 turns.
8. Once the ram has fully retracted remove the work piece.
9. When not in use, position the ram fully retracted and disconnect Air Supply.



Raising and Lowering Press Bed



- 1) Rotate the Crank Assembly (11) slightly to take the weight of the Press Bed (23) off of the Press Bed Pins (12). Remove the Locking Circlips (13) and remove the Press Bed Pins (12).

NOTE: Keep hands and body well clear of Press Bed (23) when raising or lowering the Press Bed.

- 2) Slowly lower or raise the Press Bed (23) using the Crank Assembly (11) until the desired height is reached.
- 3) Insert Press Bed Pins (12) fully through the Press Bed and Press Legs and secure with the Locking Circlips (13)
- 4) Release the weight of the Press Bed onto the 4 Press Bed Pins (12)
- 5) **IMPORTANT: Press Bed must be resting firmly on all 4 Press Bed Pins (12) and they MUST be locked in position using the Circlips (13)**

MAINTENANCE

- Daily inspections should be made prior to working with this piece of equipment.
- Clean the outside of the press with dry, clean and soft cloth and periodically lubricate the hoist, wheel shaft assembly, the joints and all moving parts with a light oil in normal service.
- **DO NOT** allow lubricant on heel block or frame / bed of shop press.
- When not in use, store the press with ram and piston fully retracted.
- When press efficiency drops, purge away air from the hydraulic system as described before.
- Check the hydraulic oil: remove the oil filler plug (49) on the top of the reservoir, if the oil is not adequate, fill with a high quality hydraulic jack oil as necessary, then replace the oil filler nut, purge away air from the hydraulic system as described before.



AMERICANFORGE&FOUNDRY™

Super Duty Shop Presses Featuring New Polycarbonate Design Protector Shield

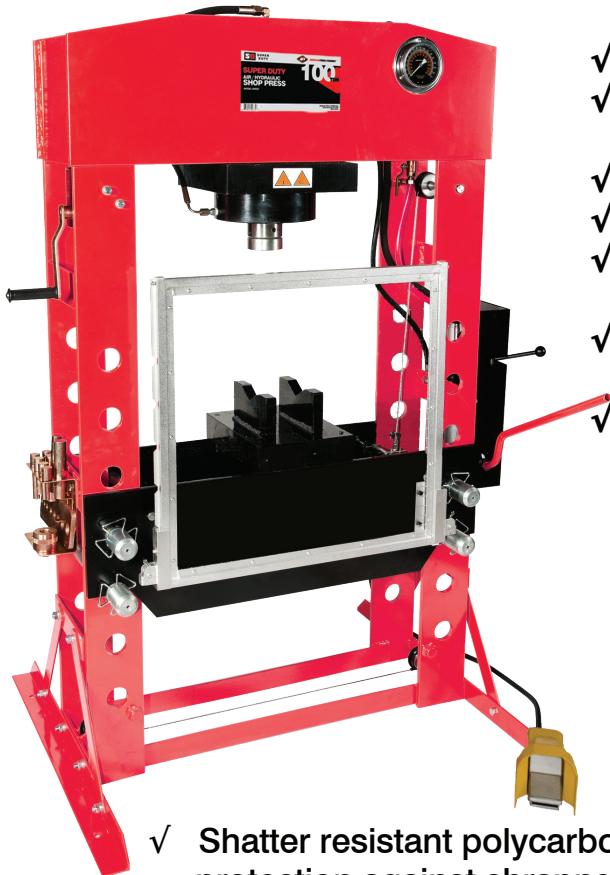

- ✓ Welded construction for exceptional strength and durability
- ✓ Includes 2 pc press plate set and 10 pc pin and bearing press adapter set
- ✓ Dual air motor operation for faster pressing process
- ✓ Glycerin filled gauge accurately shows pressing force
- ✓ 7 position bed height configuration for ultimate operator flexibility
- ✓ Lateral head adjuster provides smooth side to side movement of the press head
- ✓ Heavy duty cable winch for effortless bed adjustment (Cable Winch featured on 50, 75, and 100 ton models)



**SUPER
DUTY**

- ✓ Shatter resistant polycarbonate material provides maximum protection against shrapnel and other debris
- ✓ Standard on all Super Duty Shop Presses ending in "ASD"
- ✓ Need to update your old shop press? Order the following :

- 850ASD-P Fits 20 ton Super Duty models
- 852ASD-P Fits 30 ton Super Duty models
- 854ASD-P Fits 50 ton Super Duty models
- 856ASD-P Fits 75 ton Super Duty models
- 859ASD-P Fits 100 ton Super Duty models

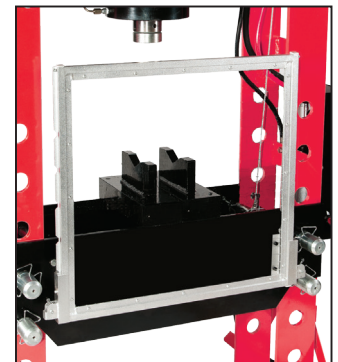

MODEL	CAPACITY (TONS)	RAM STROKE	OVERALL DIMENSIONS	BED DEPTH	BED WIDTH	THROAT DEPTH	THROAT WIDTH	WEIGHT (LBS)
850ASD	20	7.50"	35"Wx64"H	7.00"	19.25"	5.75"	10.75"	282 lbs.
852ASD	30	5.90"	40"Wx71"H	7.25"	21.50"	6.50"	15.00"	363 lbs.
854ASD	50	7.75"	54"Wx75"H	10.12"	28.75"	7.25"	16.75"	660 lbs.
856ASD	75	9.75"	57"Wx77"H	10.87"	31.50"	8.00"	19.75"	1030 lbs.
859ASD	100	11.58"	55"Wx84"H	13.50"	31.00"	9.00"	16.5"	1476 lbs

[Learn more about other hydraulic presses made by AFF on our website.](#)