



**AMERICANFORGE&FOUNDRY™**

## **Ratcheting Torque Wrenches**

- ✓ Tested at +/- 4% accuracy and includes Certificate of Calibration
- ✓ Conforms to the accuracy requirements of the American Standards Institute ASME B107.14-1194, BSEN 26789:1994, ISO 6789-1992, DIN 3122, and U.S. Government Specification GGG-W-00686C
- ✓ Perceptible jolt and audible click indicate desired torque setting has been reached
- ✓ Locking collar prevents accidental setting adjustment
- ✓ Pliable handle grip for superior comfort and oil resistance
- ✓ Rubber seal between the ratchet head and tube keeps lubrication in and contaminants out
- ✓ Includes protective blow mold case for easy storage



MODEL NUMBER	DRIVE SIZE	PRIMARY SCALE RANGE	SECONDARY SCALE RANGE	TOOTH COUNT	HEAD THICKNESS	HEAD WIDTH	OVERALL LENGTH	SHIP WEIGHT
41050	1/4"	40-250 in/lbs	5-28 Nm	24	0.44	1.14	13.75"	1.63 lbs
41051	3/8"	15/80 ft/lbs	20-108 Nm	24	0.58	1.44	15.25"	2.11 lbs
41052	1/2"	30/150 ft/lbs	40-203 Nm	24	0.64	1.85	21.00"	3.75 lbs
41053	1/2"	50-250 ft/lbs	67-339 Nm	24	0.76	1.85	25.50"	5.60 lbs
41054	3/4"	100-600 ft/lbs	135-813 Nm	24	1.04	2.85	43.00"	13.07 lbs
41055	1"	100-700 ft/lbs	135-949 Nm	24	1.04	2.85	48.00"	14.21 lbs



## CERTIFICATE OF CALIBRATION

Serial No. : \_\_\_\_\_

Model #	Drive	Torque Setting	Minimum Allowable	Maximum Allowable	Actual Readings
41050	1/4"	50.0	48.0	52.0	
		150.0	144.0	156.0	
		250.0	240.0	260.0	
41051	3/8"	16.0	15.4	16.6	
		48.0	46.1	49.9	
		80.0	76.8	83.2	
41052	1/2"	30.0	28.8	31.2	
		90.0	86.4	93.6	
		150.0	144.0	156.0	
41053	1/2"	50.0	48.0	52.0	
		150.0	144.0	156.0	
		250.0	240.0	260.0	
41054	3/4"	120.0	115.2	124.8	
		360.0	345.6	374.4	
		600.0	576.0	624.0	
41055	1"	140.0	134.4	145.6	
		420.0	403.2	436.8	
		700.0	672.0	728.0	

This torque wrench has been factory calibrated and found to conform to the accuracy requirements (+/- 4%) of the American Standards Institute ASME B107.14-1994, BSEN 26789:1994, ISO 6789-1992, DIN 3122, and U.S. Government Specification GGG-W-00686C.

Tested By: \_\_\_\_\_ Date: \_\_\_\_\_



# AMERICANFORGE&FOUNDRY™

Dear Customer,

You have purchased a high quality American Forge & Foundry micrometer torque wrench. It is a fine precision instrument with a release accuracy of +/- 4% of the torque setting.

Please read and carefully observe the following operating instructions.

## ADJUSTMENT OF THE TORQUE VALUE

1. Pull lock ring to “UNLOCK” position (see FIGURE A1.)
2. Turn handle until upper edge aligns itself with the desired torque setting (ie..90 ft/lbs as shown in FIGURE B1.)
3. Use the scale on the beam as well as the values on the handle to achieve desired torque setting.
4. Push lock ring to “LOCK” position (see FIGURE A2.)
5. Torque wrench can be set to ft/lbs (primary scale) or Nm (secondary scale)

## OPERATION

1. Operate the torque wrench in the lower torque range upon first use or following a lengthy storage period to ensure the mechanism is uniformly lubricated.
2. Set the desired torque.
3. Pull slowly and evenly towards you. Once torque is reached it is signaled by a perceptible jolt and by a simultaneous clicking noise. Please note the signal becomes proportionally louder as the torque setting is increased. Once the set torque has been achieved stop pulling immediately.

## NOTE

1. Do not use an extension or other device when operating the torque wrench. This will prevent the set torque value from being correctly signaled.
2. Never set the torque value above or below the limit of the scale.
3. Do not continue to apply pressure after torque value is reached. This may result in damage to the work or fastener.
4. Handle your torque wrench as carefully as you would treat a measuring instrument.

## MAINTENANCE AND INSPECTION

1. Set the torque to the lowest setting after each use to relieve stress on the compressive spring.
2. Use only dry materials to clean the wrench. Do not dip in gasoline or solvent.
3. The calibration of the wrench should be inspected every 6 months using suitable test equipment. Continuous use of the wrench may require more frequent testing.

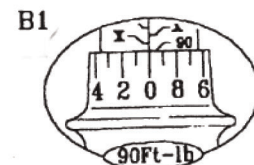
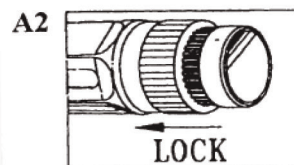
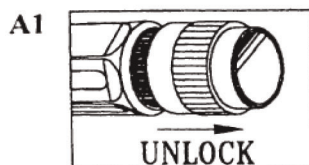



# MODEL 41054 3/4" DR TORQUE WRENCH

UPDATED 3/06

PART ORDER NUMBER	KIT DESCRIPTION	KIT INCLUDES		
		REF. #	DESCRIPTION	
41054RK	REPAIR KIT		REPAIR KIT	
41054-13	ADJ SCREW	13	ADJ SCREW	
41054-16	C CLIP	16	C CLIP	
41054-19	RUBBER PLUG	19	RUBBER PLUG	
41054-22	ROLLER BRKT ASSM	22	ROLLER BRKT ASSM	
41054-24	SPRING	24	SPRING	
41054-26	WASHER	26	WASHER	
41054-27	STUD ADJ SCREW	27	STUD ADJ SCREW	
41054-29	HANDLE W/SCALE	29	HANDLE W/SCALE	
41054-31	INNER CAP NUT	31	INNER CAP NUT	
41054-32	CAP NUT	32	CAP NUT	
41054-33	INNER ADJ LOCK	33	INNER ADJ LOCK	
41054-34	SPRING	34	SPRING	
41054-35	BALL 2.5 MM	35	BALL 2.5 MM	
41054-36	LOCK	36	LOCK	
41054-37	WASHER	37	WASHER	
41054-38	SCREW	38	SCREW	

**\* ONLY PARTS WITH A "PART ORDER NUMBER" ARE AVAILABLE FOR SALE.**

**DO NOT COPY OR DISTRIBUTE THIS MATERIAL WITHOUT PERMISSION OF AFF, INC.**

# MODEL 41054 3/4" DR TORQUE WRENCH

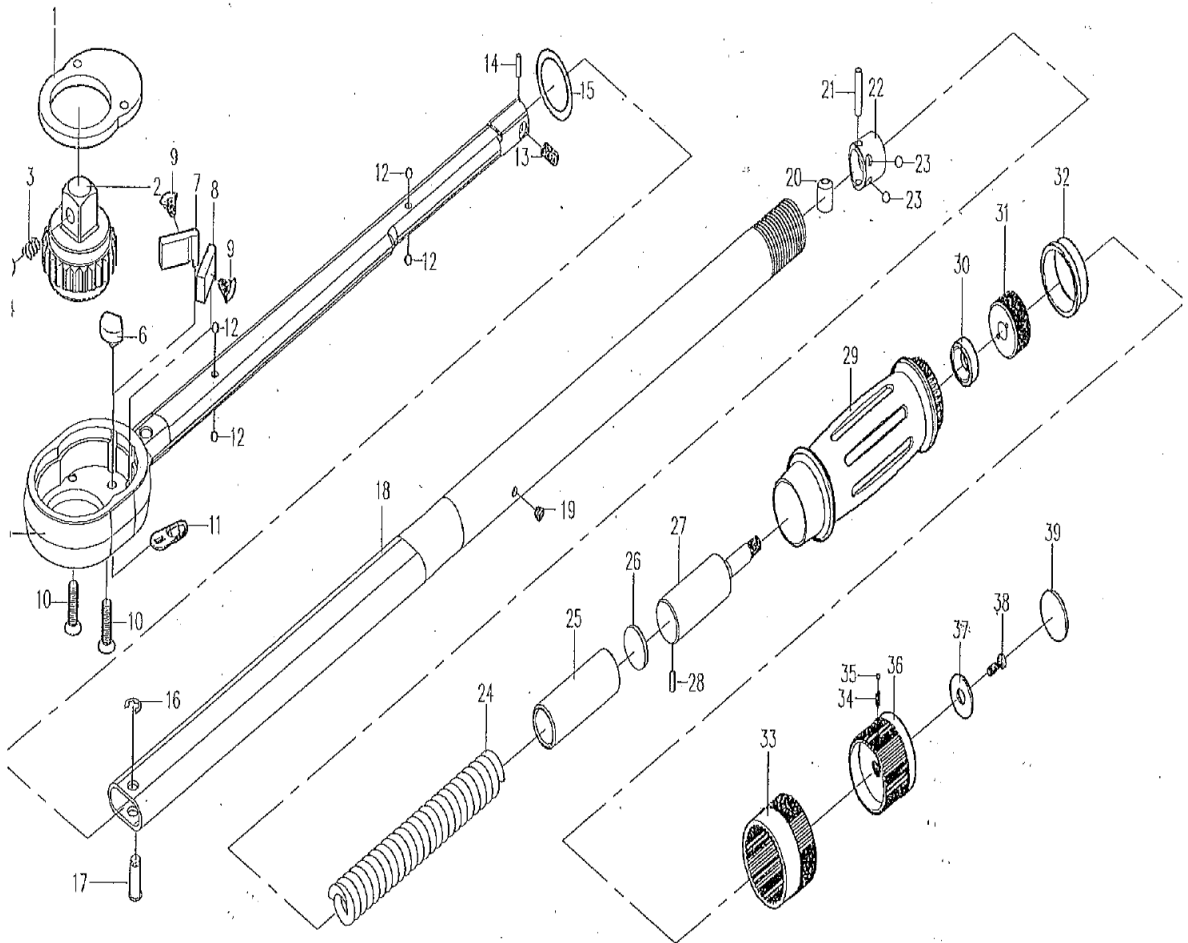

**DO NOT COPY OR DISTRIBUTE THIS MATERIAL WITHOUT PERMISSION OF AFF, INC.**

1	GEAR COVER	
2	GEAR HEAD incl.#3 ball & #4 spring	
5	H HANDLE	
6	CONVEX GEAR	
7	PAWL-RIGHT SIDE PIECE	
8	PAWL-LEFT SIDE PIECE	
9	SPRING 2-pc/set	
10	COVER SCREW 2pc/set	
11	Direction Knob	
12	BALL 3/16" 4pc/set	
13	ADJ SCREW	
14	PIN	
15	O-RING	
16	C CLIP	
17	PIN	
18	LONG TUBE F/N	
19	RUBBER PLUG	
22	ROLLER BRKT ASSY (P/N 20~23)	
24	SPRING	
25	Sleeve	
26	WASHER	
27	STUD ADJUSTMENT SCREW	
28	PIN	
29	HANDLE WITH SCALE	
30	BEARING	
31	INNER CAP NUT	
32	CAP NUT	
33	INNER ADJUSTMENT LOCK 40T, Blue	
34	SPRING	
35	BALL (2.5mm)	
36	LOCK	
37	WASHER	
38	SCREW	
*****	REPAIR KIT CONTAINS ILLUSTRATION #'S 1,2,3,4,6,7,8,9,10,11	