



RANDOM ORBITAL SANDER ELITE SERIES INSTRUCTION MANUAL

127 mm (5 in.) and 152 mm (6 in.)

12,000 RPM

Important Safety Information

Please read understand and follow all safety information contained in these instructions prior to the use of this tool. Retain these instructions for future reference.



Intended Use

This pneumatic tool is intended for use in industrial locations, and used only by skilled, trained professionals in accordance with the instructions in this manual. This pneumatic tool is designed to be used with a disc pad and appropriate abrasive for sanding metals, wood, stone, plastics and other materials. It should only be used for such sanding applications and within marked capacity and ratings. Only accessories specifically recommended by 3M should be used with this tool. Use in any other manner or with other accessories could lead to unsafe operating conditions.



Do not operate tool in water or in an excessively wet application.

Do not use disc pads that have a Max RPM less than the tool Max RPM rating. Never use disc pads that have a weight and/or size different than what the tool was specifically designed for.



Summary of device labels containing safety information

Marking	Description
 	 WARNING: Refer to Instruction Manual
Always operate at 90 PSIG / 6.2 bar max	Maximum Pneumatic Inlet Pressure
12,000 RPM	Maximum Rotational Speed
Hand / Wrist / Arm injury can occur with prolonged exposure to vibration	Vibration Safety Note

Explanation of Signal Word Consequences

 WARNING:	Indicates a potentially hazardous situation which, if not avoided, may result in death or serious injury and/or property damage.
 CAUTION:	Indicates a potentially hazardous situation which, if not avoided, may result in minor or moderate injury and/or property damage.

Read the Material Safety Data Sheets (MSDS) before using any materials.

Contact the suppliers of the workpiece materials and abrasive materials for copies of the MSDS if one is not readily available.

 **WARNING**

Exposure to **DUST** generated from workpiece and/or abrasive materials can result in lung damage and/or other physical injury.

Use dust capture or local exhaust as stated in the MSDS. Wear government-approved respiratory protection and eye and skin protection.

Failure to follow this warning can result in serious lung damage and/or physical injury.



WARNING

To reduce the risks associated with impact from abrasive product, pad, or tool breakup, sharp edges, hazardous pressure, rupture, vibration and noise:

- Read, understand and follow the safety information contained in these instructions prior to the use of this tool. Retain these instructions for future reference.
- Only personnel who are properly trained should be allowed to service this tool.
- Practice safety requirements. Work alert, have proper attire, and do not operate tools under the influence of alcohol or drugs.
- Operators and other personnel must always wear protection for eyes, ears, and respiratory protection when in the work area or while operating this product. Follow your employer's safety policy for PPE's and/or ANSI Z87.1 or local/national standards for eyewear and other personal protective equipment requirements.
- Wear protective apparel, taking into consideration the type of work being done.
- On overhead work, wear a safety helmet.
- Never exceed marked maximum input pressure (90psi/.62Mpa/6.2Bars).
- Proper eye protection must be worn at all times.
- Tool is not to be operated in the presence of bystanders.
- If you notice any abnormal noise or vibration when operating the tool, immediately discontinue its use and inspect for worn or damaged components. Correct or replace the suspect component. If abnormal noise or vibration still exists, return the tool to 3M for repair or replacement. Refer to warranty instructions.
- Do not modify this sander or polisher. Modifications may reduce the effectiveness of safety measures and increase the risks to the operator.
- Never operate this tool without all safety features in place and in proper working order.
- Never over-ride or disable the safety features of the start-stop control such that it is in the on position.
- Make sure the tool is disconnected from its air source before servicing, inspecting, maintaining, cleaning, and before changing abrasive product.
- Prior to use, inspect abrasive product and accessories for possible damage. If damaged, replace with new abrasive product and accessories available from 3M.
- Only use accessories supplied or recommended by 3M.
- Never allow this tool to be used by children or other untrained people.
- Do not leave an unattended tool connected to air source.
- Immediately discontinue use of tool if its noise reduction muffler system has been damaged or is otherwise not functioning properly. Have tool repaired before placing back into use.

To reduce the risks associated with vibration:

- If any physical hand/wrist discomfort is experienced, work should be stopped promptly to seek medical attention. Hand, wrist and arm injury may result from repetitive work, motion and overexposure to vibration.

To reduce the risks associated with loud noise:

- Unprotected exposure to high noise levels can cause permanent, disabling, hearing loss and other problems such as tinnitus (ringing, buzzing, whistling or humming in the ears).
- Always wear hearing protection while operating this tool. Follow your employer's safety policy or local/national standards for personal protective equipment requirements.

To reduce the risks associated with fire or explosion:

- Do not operate the tool in explosive atmospheres, such as in the presence of flammable liquids, gases, or dust. The abrasives are able to create sparks when working material, resulting in the ignition of the flammable dust or fumes.
- Refer to MSDS of material being worked as to potential for creating fire or explosion hazard.

To reduce the risks associated with hazardous dust ingestion or eye/skin exposure:

- Dusts and fumes generated when using sanders and polishers can cause ill health (for example: cancer, birth defects, asthma and/or dermatitis); risk assessment of these hazards and implementation of appropriate controls of is essential.
- Risk assessment should include dust created by the use of the tool and the potential for disturbing existing dust.
- Operate and maintain the sander or polisher as recommended in these instructions, to minimise dust or fume emissions.
- Direct the exhaust so as to minimise disturbance of dust in a dust filled environment.
- Where dusts or fumes are created, the priority shall be to control them at the point of emission.
- All integral features or accessories for the collection, extraction or suppression of airborne dust or fumes should be correctly used and maintained in accordance with the manufacturer's instructions.
- Select, maintain and replace the consumable/inserted tool as recommended in these instructions, to prevent an unnecessary increase in dust or fumes.
- Use respiratory protection as instructed by your employer and as required by occupational health and safety regulations.
- Use appropriate respiratory and skin protection, or local exhaust as stated in the MSDS of the material being worked on.

To reduce the risks associated with hazardous voltage:

- Do not allow this tool to come into contact with electrical power sources as the tool is not insulated against electrical shock.

CAUTION

To reduce the risks associated with skin abrasion, burns, cuts, or entrapment:

- Keep hands, hair, and clothing away from the rotating part of the tool.
- Wear suitable protective gloves while operating tool.
- Do not touch the rotating parts during operation for any reason.
- Do not force tool or use excessive force when using tool.

To reduce the risks associated with whipping or hazardous pressure-rupture:

- Whenever universal twist couplings (claw couplings) are used, lock pins shall be installed and whipcheck safety cables shall be used to safeguard against possible hose to tool and hose to hose connection failure.
- Ensure supply hose is oil resistant and is properly rated for required working pressure.
- Do not use tools with loose or damaged air hoses or fittings.
- Be aware that incorrectly installed hoses and fittings might unexpectedly come loose at any time and create a whipping/impact hazard.

To reduce the risks associated with fly off of abrasive product or parts:

- Use care in attaching abrasive product and pad; following the instructions to ensure that they are securely attached to the tool before use.
- Never free speed the tool or otherwise allow it to be started unintentionally.
- Never point this product in the direction of yourself or another person, or start tool unintentionally.
- Never over-tighten accessory fasteners.

Parts Page & Assembly Instructions

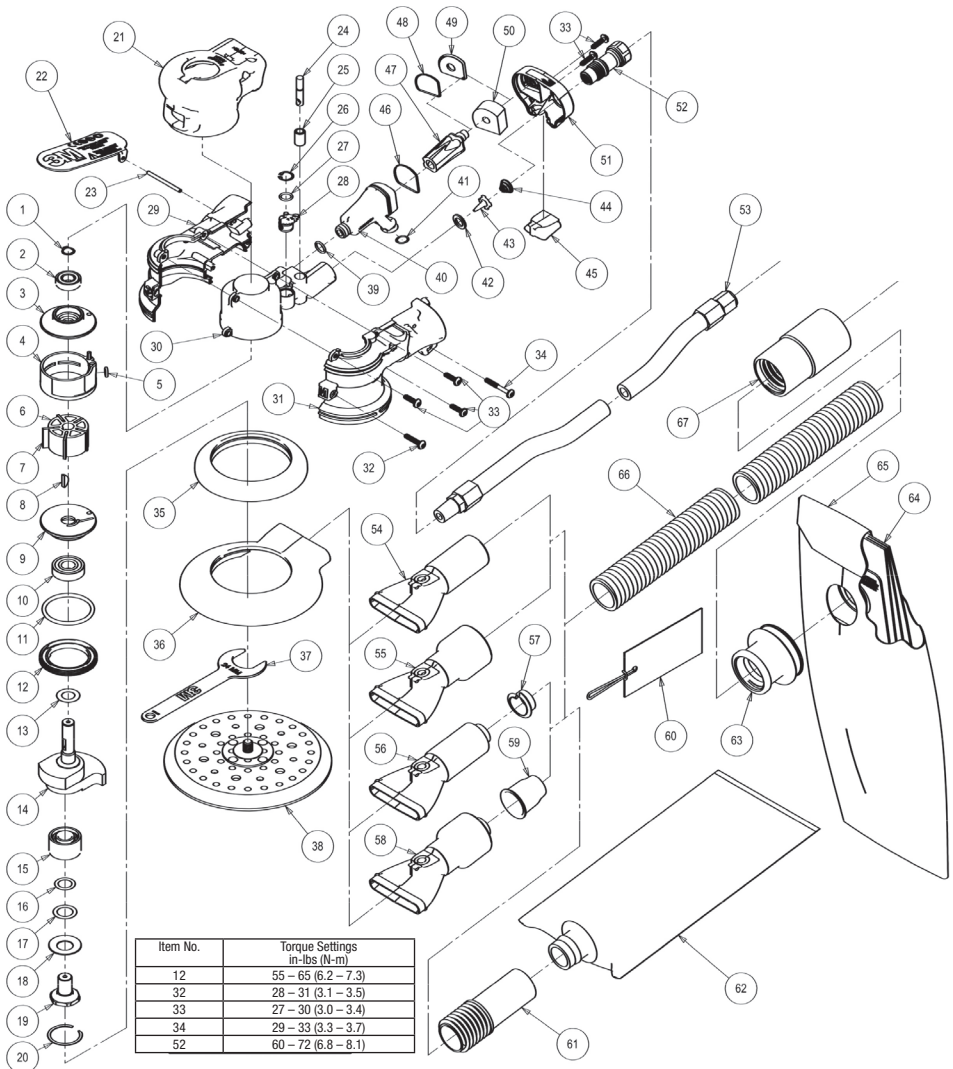

Parts List

ITEM	3M UPC PN	3M PN	DESCRIPTION	QTY
1	28113	A0040	External Retaining Ring	1
2	55185	55185	Bearing, 10 mm x 22 mm x 6 mm deep Groove Ball (2 Shields, 6900ZZ)	1
3	55174	55174	Rear Endplate, Elite	1
4	30347	30347	Cylinder Assembly	1
5	28115	A0042	O-Ring, 5 mm x 2 mm	1
6	28170	B0005	Machined Rotor	1
7	28099	A0010	Vane	5
8	28114	A0041	3 mm x 13 mm Woodruff Key	1
9	30326	30326	Front Endplate	1
10	28776	28776	12 mm x 28 mm x 8 mm Bearing - 2 Rubber Seals	1

Parts List

ITEM	3M UPC PN	3M PN	DESCRIPTION	QTY
11	28118	A0045	O-Ring, 39.4 mm x 3.1 mm	1
12	30337	30337	Lock Ring, 50 mm Thread	1
13	55186	55186	Front Bearing Dust Shield	1
14	28178	B0277	Shaft Balancer, 5 in. x 3/16 in. (5 mm) Orbit, Elite	1
	28179	B0278	Shaft Balancer, 6 in. x 3/16 in. (5 mm) Orbit, Elite	1
	28180	B0279	Shaft Balancer, 5 in. x 3/32 in. (2.5 mm) Orbit, Elite	1
	28181	B0280	Shaft Balancer, 6 in. x 3/32 in. (2.5 mm) Orbit, Elite	1
	28184	B0334	Shaft Balancer, 6 in. x 5/16 in. (8 mm) Orbit, Elite	1
	30325	B0348	Shaft Balancer, 5 in. x 5/16 in. (8 mm) Orbit, Elite	1
	28615	28615	Shaft Balancer, 5 in. x 3/8 in. (10 mm) Orbit, Elite	1
	28616	28616	Shaft Balancer, 6 in. x 3/8 in. (10 mm) Orbit, Elite	1
15	28148	A0938	12 mm x 28 mm x 16 mm Double Row Angular Contact Dearing - 1 Seal	1
16	28103	A0016	Spacer 12.1 mm ID x 18.0 mm OD x 0.2 Thick	1
17	55187	55187	Spindle Bearing Dust Shield	1
18	28104	A0017	Belleville Washer	1
19	28174	B0018	Spindle	1
20	28105	A0018	Retaining Ring	1
21	55204	55204	2 1/2 in. (65 mm) Grip, Elite	OPT
	55205	55205	2 3/4 in. (69 mm) Grip, Elite	1
	55206	55206	3 in. (75 mm) Grip, Elite	OPT
22	55181	55181	3M™ Random Orbital Sander 2.5 mm (3/32 in.) Orbit Lever, 12,000 RPM, Elite	1
	55182	55182	3M™ Random Orbital Sander 5.0 mm (3/16 in.) Orbit Lever, 12,000 RPM, Elite	1
	55183	55183	3M™ Random Orbital Sander 8.0 mm (5/16 in.) Orbit Lever, 12,000 RPM, Elite	1
	28617	28617	3M™ Random Orbital Sander 10.0 mm (3/8 in.) Orbit Lever, 12,000 RPM, Elite	1
23	28109	A0031	Lever Spring Pin	1
24	28097	A0008	Valve Stem Assembly	1
25	28102	A0015	Valve Sleeve	1
26	28112	A0039	Internal Retaining Ring	1
27	28116	A0043	O-Ring, 9 mm x 1.5 mm	1
28	55172	55172	Speed Control, Elite	1
29	55208	55208	Right Hand Housing - 5/6 in. (125/150 mm), Elite	1
30	55199	55199	Inner Housing, Machined - 5/6 in. (125/150 mm), NV & CV Elite	1
30	55433	55433	Inner Housing, Machined - 5/6 in. (125/150 mm), SGV Elite	1
31	55207	55207	Left Hand Housing - 5/6 in. (125/150 mm), Elite	1
32	55196	55196	Screw, Button Head Torx M4 x 20 mm	1
33	30321	30321	Screw, Button Head Torx M4 x 15 mm	5
34	30322	30322	Screw, Button Head Torx M4 x 30 mm	1
35	28158	A1346	5/6 in. Random Orbital Sander, Non-Vacuum Shroud	1
36	55203	55203	Ø 6 in. Low Profile Shroud, Elite	1
36	55216	55216	Ø 5 in. Low Profile Shroud, Elite	1
37	28108	A0022	24 mm Pad Wrench	1
38	N/A	N/A	1 Pad Supplied With Each Tool (Type Determined By Model)	1
39	28116	A0043	O-Ring, 9 mm x 1.5 mm	1
40	55198	55198	Exhaust Chamber	1
41	55165	55165	O-Ring, 9.5 mm x 1 mm	1
42	28098	A0009	Valve Seat	1
43	28096	A0007	Valve	1
44	28101	A0014	Valve Spring	1
45	55166	55166	Non-Vacuum Cover, Elite	1
46	55175	55175	O-Ring, 28 mm x 1 mm	1
47	55191	55191	Internal Muffler Assembly, NV and CV	1
	28840	28840	Internal Muffler Assembly, 5"/6" SGV ROS	1
48	55176	55176	O-Ring, 24 mm x 1 mm	1
49	55173	55173	Self-Generating Exhaust Cap, Elite	1
50	55179	55179	Muffler, Elite	1
51	55201	55201	End Cap, Elite	1
52	55171	55171	Inlet Bushing Assembly, Elite	1
53	20209	20209	3/8 in Ø x 4 feet air line with ¼ in. Ø Compression fittings	OPT
54	55167	55167	Central-Vacuum Swivel Exhaust Fitting - 3/4 in./19 mm Hose	OPT
55	55168	55168	Central-Vacuum Swivel Exhaust Fitting - 1 in./28 mm Hose	1
56	55169	55169	Self-Generating Vacuum Swivel Exhaust Fitting - 3/4 in./19 mm Hose	OPT
57	N/A	N/A	3/4 in./19 mm Hose Seal	N/A
58	55170	55170	Self-Generating Vacuum Swivel Exhaust Fitting - 1 in./28 mm Hose	1
59	28146	A0778	1 in./28 mm Hose Seal	1
60	N/A	N/A	Tag with Instruction for 3M 1 in./28 mm Hose Seal	1
61	20453	20453	3M™ Filter Bag Adaptor, 1 in. EXT Hose Thread x 1 in. OD	1
62	20452	20452	3M™ Clean Sanding Filter Bag (5 in. x 12 in.)	1
63	28302	28302	1 in. Double Bag Vacuum Fitting	OPT*
64	20338	20338	Vacuum Bag Insert	OPT*
65	28303	A1434	3M™ Vacuum Bag	OPT*
66	28301	28301	Ø 1 in. x 6 ft. Vacuum Hose	OPT*
67	30324	30324	Hose End Adaptor - 1 in./28 mm Hose Thread x 1 1/2 in. OD	OPT*
67	20341	20341	Hose End Adaptor 3/4 in. Hose Thread x 1 in./28 mm Hose Thread	OPT*

* Items 63-67 are included with Model Numbers 28621 and 28625. Items 61-62 are not included with these models.

Product Configuration/Specifications: 12,000 RPM Random Orbital Sander

Model Number	Vacuum Type	Orbit mm (in)	Pad Size mm (in)	Product Net WT kg (lb)	Height mm (in)	Length mm (in)	*Noise Level dBA Pressure (Power)	*Uncertainty dBA Pressure (Power)	**Vibration Level m/s ² (ft/s ²)	**Uncertainty K m/s ² (ft/s ²)
28583	Non Vacuum	10 (3/8)	127 (5)	0.825 (1.81)	91 (3.58)	172 (6.77)	74 (85)	0.53 (0.32)	2.3 (7.55)	0.72 (2.36)
28495*	Non Vacuum	8 (5/16)	127 (5)	0.817 (1.8)	91 (3.58)	172 (6.77)	74 (85)	0.53 (0.32)	3.6 (11.81)	0.85 (2.79)
28497	Non Vacuum	5 (3/16)	127 (5)	0.8 (1.76)	91 (3.58)	172 (6.77)	74 (85)	0.53 (0.32)	3.49 (11.45)	0.84 (2.75)
28498	Non Vacuum	2.5 (3/32)	127 (5)	0.781 (1.72)	91 (3.58)	172 (6.77)	74 (85)	0.53 (0.32)	3.35 (10.99)	0.83 (2.72)
28582	Non Vacuum	10 (3/8)	150 (6)	0.881 (1.94)	91 (3.58)	187 (7.36)	75 (86)	0.51 (0.27)	3.46 (11.35)	0.84 (2.76)
28499	Non Vacuum	8 (5/16)	150 (6)	0.869 (1.91)	91 (3.58)	187 (7.36)	75 (86)	0.51 (0.27)	3.09 (10.14)	0.80 (2.62)
28701	Non Vacuum	8 (5/16)	150 (6)	0.869 (1.91)	91 (3.58)	187 (7.36)	75 (86)	0.51 (0.27)	2.88 (9.45)	0.78 (2.56)
28500*	Non Vacuum	5 (3/16)	150 (6)	0.844 (1.86)	91 (3.58)	187 (7.36)	75 (86)	0.51 (0.27)	2.81 (9.22)	0.77 (2.53)
28703	Non Vacuum	5 (3/16)	150 (6)	0.844 (1.86)	91 (3.58)	187 (7.36)	75 (86)	0.51 (0.27)	3.17 (10.40)	0.81 (2.66)
28501	Non Vacuum	2.5 (3/32)	150 (6)	0.957 (2.1)	91 (3.58)	187 (7.36)	75 (86)	0.51 (0.27)	2.99 (9.81)	0.79 (2.59)
28560	Central Vacuum	10 (3/8)	150 (6)	0.930 (2.04)	92.6 (3.64)	238 (9.37)	76 (87)	0.49 (0.22)	2.35 (7.71)	0.73 (2.40)
28502	Central Vacuum	8 (5/16)	150 (6)	0.918 (2.02)	92.6 (3.64)	238 (9.37)	76 (87)	0.49 (0.22)	3.19 (10.47)	0.81 (2.66)
28561	Central Vacuum	10 (3/8)	127 (5)	0.868 (1.91)	92.6 (3.64)	227 (8.93)	73 (84)	0.50 (0.16)	3.26 (10.70)	0.82 (2.69)
28504*	Central Vacuum	8 (5/16)	127 (5)	0.86 (1.89)	92.6 (3.64)	227 (8.93)	73 (84)	0.50 (0.16)	2.51 (8.23)	0.74 (2.43)
28506	Central Vacuum	5 (3/16)	127 (5)	0.844 (1.86)	92.6 (3.64)	227 (8.93)	73 (84)	0.50 (0.16)	2.78 (9.12)	0.77 (2.53)
28507	Central Vacuum	2.5 (3/32)	127 (5)	0.826 (1.82)	92.6 (3.64)	227 (8.93)	73 (84)	0.50 (0.16)	2.6 (8.53)	0.75 (2.46)
28508	Central Vacuum	5 (3/16)	150 (6)	0.896 (1.97)	92.6 (3.64)	238 (9.37)	76 (87)	0.49 (0.22)	2.96 (9.71)	0.79 (2.59)
28509*	Central Vacuum	2.5 (3/32)	150 (6)	0.869 (1.91)	92.6 (3.64)	238 (9.37)	76 (87)	0.49 (0.22)	2.92 (9.58)	0.78 (2.56)
28562*	Self-Gen Vacuum	10 (3/8)	150 (6)	0.939 (2.06)	92.6 (3.64)	245 (9.64)	85 (96)	0.50 (0.20)	3.09 (10.14)	0.82 (2.69)
28510	Self-Gen Vacuum	8 (5/16)	150 (6)	0.927 (2.04)	92.6 (3.64)	245 (9.64)	85 (96)	0.50 (0.20)	2.78 (9.12)	0.77 (2.53)
28702	Self-Gen Vacuum	8 (5/16)	150 (6)	0.927 (2.04)	92.6 (3.64)	245 (9.64)	85 (96)	0.50 (0.20)	2.79 (9.15)	0.77 (2.53)
28563	Self-Gen Vacuum	10 (3/8)	127 (5)	0.874 (1.93)	92.6 (3.64)	234 (9.21)	86 (97)	0.51 (0.32)	2.13 (6.99)	0.71 (2.33)
28512	Self-Gen Vacuum	8 (5/16)	127 (5)	0.866 (1.9)	92.6 (3.64)	234 (9.21)	86 (97)	0.51 (0.32)	2.97 (9.75)	0.79 (2.59)
28514*	Self-Gen Vacuum	5 (3/16)	127 (5)	0.85 (1.87)	92.6 (3.64)	234 (9.21)	86 (97)	0.51 (0.32)	2.87 (9.42)	0.78 (2.56)
28515	Self-Gen Vacuum	2.5 (3/32)	127 (5)	0.833 (1.83)	92.6 (3.64)	234 (9.21)	86 (97)	0.51 (0.32)	2.71 (8.89)	0.76 (2.49)
28516	Self-Gen Vacuum	5 (3/16)	150 (6)	0.904 (1.99)	92.6 (3.64)	245 (9.64)	85 (96)	0.50 (0.20)	3.52 (11.55)	0.84 (2.76)
28704	Self-Gen Vacuum	5 (3/16)	150 (6)	0.904 (1.99)	92.6 (3.64)	245 (9.64)	85 (96)	0.50 (0.20)	3.59 (11.78)	0.85 (2.79)
28517	Self-Gen Vacuum	2.5 (3/32)	150 (6)	0.874 (1.92)	92.6 (3.64)	245 (9.64)	85 (96)	0.50 (0.20)	3.76 (12.34)	0.87 (2.85)
28457	Non Vacuum	5 (3/16)	127 (5)	0.8 (1.76)	91 (3.58)	172 (6.77)	74 (85)	0.53 (0.32)	3.49 (11.45)	0.84 (2.76)
28708	Non Vacuum	5 (3/16)	127 (5)	0.8 (1.76)	91 (3.58)	172 (6.77)	74 (85)	0.53 (0.32)	3.49 (11.45)	0.84 (2.76)
28460	Non Vacuum	5 (3/16)	150 (6)	0.844 (1.86)	91 (3.58)	187 (7.36)	75 (86)	0.51 (0.27)	2.81 (9.22)	0.77 (2.53)
28461	Central Vacuum	5 (3/16)	150 (6)	0.896 (1.97)	92.6 (3.64)	238 (9.37)	76 (87)	0.49 (0.22)	2.51 (8.23)	0.74 (2.43)
28462	Self-Gen Vacuum	5 (3/16)	150 (6)	0.904 (1.99)	92.6 (3.64)	245 (9.64)	85 (96)	0.50 (0.20)	3.52 (11.55)	0.84 (2.76)
28621	Self-Gen Vacuum	5 (3/16)	127 (5)	0.85 (1.87)	92.6 (3.64)	234 (9.21)	86 (97)	0.51 (0.32)	2.87 (9.42)	0.78 (2.56)
28625	Self-Gen Vacuum	5 (3/16)	150 (6)	0.904 (1.99)	92.6 (3.64)	245 (9.64)	85 (96)	0.50 (0.20)	3.59 (11.78)	0.85 (2.79)

* Noise values are applied to mechanically identical tools, declared noise levels measured in accordance with EN ISO 15744.

** Declared vibration levels in accordance with EN ISO 12096; measurements carried out in accordance with standard EN ISO 28927-3.

IMPORTANT NOTE: The noise and vibration values stated in the table are from laboratory testing in conformity with stated codes and standards and are not sufficient risk evaluation for all exposure scenarios. Values measured in a particular work place may be higher than the declared values. The actual exposure values and amount of risk or harm experienced to an individual is unique to each situation and depends upon the surrounding environment, the way in which the individual works, the particular material being worked, work station design, as well as upon the exposure time and the physical condition of the user. 3M™ cannot be held responsible for the consequences of using declared values instead of actual exposure values for any individual risk assessment.

Operating & Maintenance Instructions

PRIOR TO THE OPERATION

The tool is intended to be operated as a hand held tool. It is always recommended that while using the tool operators stand on a solid floor in a secure position with a firm grip and footing. Be aware that the sander can develop a torque reaction. See the section "SAFETY PRECAUTIONS".

Use a clean lubricated air supply that will give a measured air pressure at the tool of 6.2 bar (90 psig) when the tool is running with the lever fully depressed. It is recommended to use an approved 10 mm (3/8 in) x 8 m (25 ft) maximum length airline. Connect the tool to the air supply as shown in Figure 1. Do not connect the tool to the airline system without an easily accessible air shut off valve. It is strongly recommended that an air filter regulator and lubricator (FRL) be used as shown in Figure 1 as this will supply clean lubricated air at the correct pressure to the tool. In any case appropriate air pressure regulators shall be used at all times while operating this tool where the supply pressure exceeds the marked maximum of the tool. Details of such equipment can be obtained for your tool distributor. If such equipment is not used the tool should be manually lubricated. To manually lubricate the tool disconnect the airline and put 2 to 3 drops of suitable pneumatic motor lubricating oil such as 3M™ Air Tool Lubricant PN 20451 Fuji Kusan FK-20 Mobil ALMO 525 or Shell TORCULA® 32 into the hose end (inlet) of the tool. Reconnect tool to the air supply and run tool slowly for a few seconds to allow air to circulate the oil. If the tool is used frequently lubricate it on a daily basis or lubricate it if the tool starts to slow or lose power. It is recommended that the air pressure at the tool be 6.2 bar (90 psig) while the tool is running so the maximum RPM is not exceeded. The tool can be run at lower pressures but should never be run higher than 6.2 bar (90 psig). If run at lower pressure the performance of the tool is reduced.

Recommended Airline Size - Minimum		Recommended Maximum Hose Length		Air Pressure	
10 mm	3/8 in	8 meters	25 feet	Maximum Working Pressure	6.2 bar 90 psig
				Recommended Minimum	NA NA

Safety Precautions

1. Read all instructions before using this tool. All operators must be fully trained in its use and aware of these safety rules.
2. The tool RPM should be checked on a regular basis to ensure proper operating speed.
3. Make sure the tool is disconnected from the air supply. Select a suitable abrasive and secure it to the pad. Be careful to center the abrasive on the pad.
4. Always wear required safety equipment when using this tool.
5. When sanding/buffing always start the tool on the workpiece. This will prevent gouging due to excess speed of the buff pad. Stop air flow to the tool as it is removed from the workpiece.
6. Always remove the air supply to the sander before fitting, adjusting or removing the abrasive or pad.
7. Always adopt a firm footing and grip and be aware of torque reaction developed by the sander.
8. Use only 3M approved spare parts.
9. Always ensure the material being sanded is firmly fixed to avoid movement.
10. Check hose and fittings regularly for wear. Do not carry the tool by its hose; always be careful to prevent the tool from being started when carrying the tool with the air supply connected.
11. Dust can be highly combustible. Keep working area clean.
12. If tool is serviced or rebuilt check to ensure that the maximum tool RPM is not exceeded and that there is no excessive tool vibration.
13. Do not exceed maximum recommended air pressure. Use safety equipment as recommended.
14. Prior to installing any sanding or polishing accessory, always check that its marked maximum operating speed is equal or higher than the rated speed of this tool.
15. The tool is not electrically insulated. Do not use where there is a possibility of contact with live electricity, gas pipes, and/or water pipes.
16. This tool is not protected against hazards inherent in grinding and cutting operations and no such accessories should ever be attached.
17. Take care to avoid entanglement with the moving parts of the tool with clothing, ties, hair, cleaning rags or loose hanging objects. If entangled, stop air supply immediately to avoid contact with moving tool parts.
18. Keep hands clear of the orbiting pad during use.
19. If the tool appears to malfunction, remove from use immediately and arrange for service and repair.
20. Immediately release the start handle in the event of any disruption of pressure; do not attempt to re-start until the disruption has been corrected.
21. When tool is not in use, store in a clean dry environment free of debris.
22. Operate tool in a well lit work area.
23. Recycle or dispose of tool according to Local, State, and Federal Regulations.
24. Whenever performing maintenance procedures, use care to avoid exposure to any hazardous substances deposited on the tool as a result of work processes. Also, refer to warnings related to dust exposure.

Description of Functions & Setting and Testing



SETTING & TESTING TOOL SPEED:

1. Ensure the Activation Lever is not depressed.
2. Connect the compressed air line.
3. Press the Activation Lever and move the Speed Control to set desired speed.
4. Use a Vibratory Tachometer to check the speed.
5. Check speed regularly.

Recommended Accessories - 3M™ Disc Pads

3M Disc Pads are perfectly mated for use in the 3M Sander. Constructed from premium, industrial-quality materials and featuring a riveted fiberglass and steel hub with molded urethane, their durability and precise construction are the ideal complement to the performance of the 3M Sander. See Product Configuration/Specifications table for the correct replacement pad for a particular model. The following chart is a sample of products offered.

Description	Part Number
3M™ Stikit™ Low Profile Disc Pad 5 in., Non-Vacuum	20351
3M™ Hookit™ Low Profile Disc Pad 5 in., Non-Vacuum	20352
3M™ Hookit™ Clean Sanding Low Profile Disc Pad 5 in., Non-Vacuum	20353
3M™ Stikit™ Low Profile Disc Pad 6 in., Non-Vacuum	20354
3M™ Hookit™ Low Profile Disc Pad 6 in., Non-Vacuum	20355
3M™ Hookit™ Clean Sanding Low Profile Disc Pad 6 in., Non-Vacuum	20356
3M™ Stikit™ Low Profile D/F Disc Pad 5 in., Non-Vacuum	20442
3M™ Stikit™ Low Profile D/F Disc Pad 6 in., Non-Vacuum	20454
3M™ Hookit™ Clean Sanding Low Profile Disc Pad-861 6 in., Non-Vacuum	20465

See 3M ASD Accessories to Optimize Performance catalog 61-5002-8098-9 and Engineered Metalworking Solutions catalog 61-5002-8097-1 for additional accessories.

Setting Up Disc Pad on Random Orbital Sander

1. Disconnect air line from sander.
2. Remove old disc pad from sander by inserting the wrench, supplied with the tool, between the rubber shroud and the disc pad. Use the wrench to secure the sander spindle while turning the disc pad counter clockwise.
3. After the old disc has been removed from the sander, inspect the threaded hole in the spindle to ensure that the threads are free of debris and undamaged.
4. Ensure that the phenolic washer is in place around the threaded shaft of the new disc pad.
5. Secure the sander spindle with the wrench and tighten the new disc pad securely to the tool.

⚠ WARNING

An inadequately tightened disc pad could cause the threaded shaft to break causing damage to the tool and work piece and possible injury to the operator or bystanders.

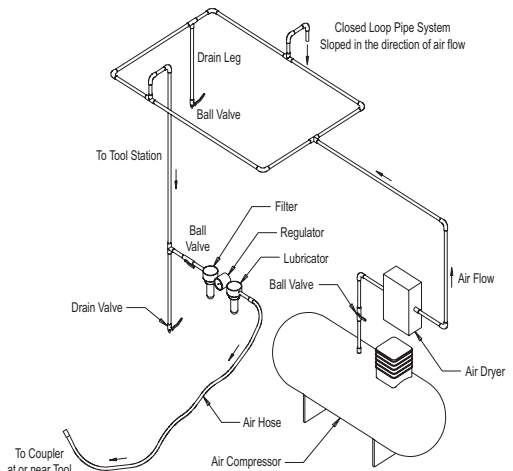

Figure 1

Check out the collection of air sanders and polishers we offer.