



Half Facepiece Respirator 7500 Series

User Instructions for 3M™ Half Facepieces Silicone, Small 7501 (37081), Silicone, Medium 7502 (37082), Silicone, Large 7503 (37083)*

Important: Keep these User Instructions for reference.

* 37077, 37078, 37079, 37081, 37082, 37083 are catalog numbers only. NIOSH approved as 3M™ Half Facepiece Silicone, Small 7501, Silicone, Medium 7502, Silicone, Large 7503.

These instructions also apply to the 3M™ Half Facepiece Silicone, Small 37077, Medium 37078 and Large 37079.*

This respirator has dual approval as a United States (US) National Institute for Occupational Safety and Health (NIOSH) half facepiece respirator and as Brazil Ministry of Labor half mask respirator. Standard specific information is provided where applicable. All other information is common to both standards.

GENERAL SAFETY INFORMATION

Intended Use

The 3M™ Half Facepiece Respirators 7500 Series are NIOSH approved and designed to help provide respiratory protection against certain airborne contaminants when used in accordance with all use instructions and limitations and applicable safety and health regulations.

This product contains no components made from natural rubber latex.



WARNING

This respirator helps protect against certain airborne contaminants. Misuse may result in sickness or death.

These User Instructions provide information about facepiece use only. Important information is provided in the User Instructions with each of the air filtration/supplied air systems that are NIOSH certified to be used with the 3M™ Half Facepiece Respirator 7500 Series. Failure to follow User Instructions for the air filtration/supplied air systems being used may result in sickness or death.

When in supplied air mode, your employer must provide breathing air that meets at least the requirements of the specification for Grade D breathing air, as described in the Compressed Gas Association Commodity Specification G-7.1-1997 in the United States. In Canada, breathing air systems must be supplied with air, which meets at least the requirements of CSA Standard Z180.1. Failure to do so may result in sickness or death.

In Brazil breathing air systems must be supplied with air, which meets ANSI Z86.1-1989/CGA G-7.1, Grade D breathing air.

USE INSTRUCTIONS & LIMITATIONS

IMPORTANT

Before use the wearer must read and understand these User Instructions. Keep these User Instructions for reference.

Use For

Respiratory protection from certain airborne contaminants according to United States NIOSH approvals, OSHA limitations, in Canada CSA standard Z94.4 requirements, applicable local government regulations and 3M instructions. In Brazil follow the Respiratory Protection Program of the Ministry of Labor.

Do Not Use For

Do not use for concentrations of contaminants which are immediately dangerous to life or health, are unknown or when concentration exceeds 10 times the permissible exposure limit (PEL) in air purifying mode, 50 times PEL in supplied air mode or according to specific United States OSHA standards or applicable local government regulations, whichever is lower.

Use Instructions

1. Failure to follow all instructions and limitations on the use of this respirator and/or failure to wear this respirator during all times of exposure can reduce respirator effectiveness and may result in sickness or death.
2. Before occupational use of this respirator a written respiratory protection program must be implemented meeting all the local government requirements. In the United States employers must comply with OSHA 29 CFR 1910.134 which includes medical evaluation, training, and fit testing and applicable OSHA substance specific standards. In Canada, follow the recommendations of CSA Z94.4 and/or requirements of the applicable jurisdiction, as appropriate. In Brazil follow the Respiratory Protection Program of the Ministry of Labor requirements. When used in supplied air mode, your employer must supply breathing air that meets at least the requirements of Grade D breathing air in Compressed Gas Association Commodity Specifications G-7.1-1997. In Canada, breathing air systems must be supplied with air which meets at least the requirements of CSA Standard Z180.1.
3. The airborne contaminants which can be dangerous to your health include those that are so small you may not be able to see or smell them.
4. Leave contaminated area immediately and contact supervisor if you smell or taste contaminants or if dizziness, irritation, or other distress occurs.
5. Store respirator away from contaminated areas when not in use.
6. Dispose of used product in accordance with applicable regulations.

In Brazil breathing air systems must be supplied with air, which meets ANSI Z86.1-1989/CGA G-7.1, Grade D breathing air.

Use Limitations

1. This respirator does not supply oxygen when used in air-purifying mode. Do not use in atmospheres containing less than 19.5% oxygen.
2. Do not use when concentrations of contaminants are immediately dangerous to life and health, are unknown or when concentrations exceed 10 times the permissible exposure limit (PEL) when used in air-purifying mode, or according to specific United States OSHA standards or applicable local government regulations, whichever is lower. When used as a straight, Type C, continuous flow supplied air respirator, the Assigned Protection Factor is 50 times the PEL or TLV guidelines for half facepiece respirators.
3. Do not alter, abuse or misuse this respirator.
4. Do not use with beards or other facial hair or other conditions that prevent a good seal between the face and the facepiece of the respirator.

Time Use Limitations

1. If respirator becomes damaged, leave contaminated area immediately and repair or replace the respirator.
2. Replace filters in accordance with the filter Time Use Limitation (See filter User Instructions).
3. Replace cartridges in accordance with an established change schedule or earlier if smell, taste or irritation from contaminants is detected.

NIOSH Cautions and Limitations

The following restrictions may apply. See NIOSH approval label.

- A - Not for use in atmospheres containing less than 19.5 percent oxygen.
- B - Not for use in atmospheres immediately dangerous to life or health.
- C - Do not exceed maximum use concentrations established by regulatory standards.
- D - Air-line respirators can be used only when the respirators are supplied with respirable air meeting the requirements of CGA G-7.1 Grade D or higher quality.
- E - Use only the pressure ranges and hose lengths specified in the User's Instructions.
- G - If airflow is cut off, switch to filter and/or cartridge or canister and immediately exit to clean air.
- H - Follow established cartridge and canister change schedules or observe ESLI to ensure that cartridge and canisters are replaced before breakthrough occurs.
- J - Failure to properly use and maintain this product could result in injury or death.
- K - The Occupational Safety and Health Administration regulations require gas-proof goggles to be worn with this respirator when used against formaldehyde.
- L - Follow the manufacturer's User's Instructions for changing cartridges, canister and/or filters.
- M - All approved respirators shall be selected, fitted, used, and maintained in accordance with MSHA, OSHA, and other applicable regulations.
- N - Never substitute, modify, add, or omit parts. Use only exact replacement parts in the configuration as specified by the manufacturer.
- O - Refer to User's Instructions, and/or maintenance manuals for information on use and maintenance of these respirators.
- P - NIOSH does not evaluate respirators for use as surgical masks.
- S - Special or critical User's Instructions and/or specific use limitations apply. Refer to User's Instructions before donning.

S - Special or Critical User Instructions

3M™ Organic Vapor Service Life Indicator Cartridges (60011 and 60921) and Mercury Vapor Cartridges (6009S and 60929S) are equipped with a passive 3M™ End of Service Life Indicator (ESLI). The indicator must be readily seen when wearing the respirator. If you cannot readily see the ESLI, use a mirror to observe the ESLI, rely on a co-worker who can see the ESLI, or go to a clean area, remove the respirator and view the ESLI. Do not rely solely on the organic vapor ESLI unless your employer has determined that it is appropriate for your workplace. See 60011 or 60921 User Instructions for more information, including Special Instructions regarding the ESLI. The mercury vapor cartridges must be discarded when the ESLI changes to the discard color found on the mercury vapor cartridge label; or within 30 days of opening packaging; or when ESLI becomes dirty or damaged; or when odors of vapors or gases become noticeable; or according to chlorine service life, whichever occurs first. Mercury vapor has no odor.

To assemble 3M™ Dual Airline Combination Breathing Tubes with 3M™ Cartridges/Filters, the facepiece inhalation valves must be removed.

If the facepiece is to be used in air-purifying mode (without using the 3M™ Breathing Tubes SA-1600 or SA-2600), the inhalation valves must be replaced in the facepiece before use.

Cartridge and Filter Selection and Approvals

Before using any of these products, the user must read the specific use for, use limitations and warning information in the User Instructions and product packaging.

Do not exceed maximum use concentrations established by local regulatory agencies. Cartridges/filters are approved as assemblies for use with 3M™ Half Facepiece 7500 Series. For NIOSH approval, refer to approval label.

LIST OF PRODUCTS

3M™ Half Facepiece 7500 Series Replacement Parts and Accessories

Number	****AAD	Description
7501	37081	Small
7502	37082	Medium
7503	37083	Large

**** AAD part numbers are catalog numbers only. NIOSH approved as PSD part numbers

Replacement Parts (Fig. 1A)

Number	****AAD	Description
A	7581	Head Harness Assembly
B	7582	Inhalation Valves
C	7586	Cartridge/Filter Holder
D	7583	Exhalation Valve

**** AAD part numbers are catalog numbers only. NIOSH approved as PSD part numbers

Accessories

Number	****AAD	Description
504	07065	Respirator Cleaning Wipes
601		Quantitative Fit Test Adapter
6880	37002	Bayonet Cap

**** AAD part numbers are catalog numbers only. NIOSH approved as PSD part numbers

CAUTION

Failure to properly dispose of spent cartridges, filters, or respirators contaminated by hazardous materials can result in environmental harm. Handling, transportation and disposal of spent cartridges, filters, or respirators must comply with all applicable federal, state, provincial, and local laws and regulations.

3M™ Cartridges 6000 Series

Number	****AAD	Description	NIOSH Approval for respiratory protection against the following contaminants up to ten times the permissible exposure limit (PEL).
6001	07046	Organic Vapor	Certain organic vapors
60011		Organic Vapor with Service Life Indicator	Certain organic vapors
6002		Acid Gas	Chlorine, hydrogen chloride, and sulfur dioxide or chlorine dioxide or hydrogen sulfide
6003	07047	Organic Vapor/Acid Gas	Certain organic vapors, chlorine, hydrogen chloride, and sulfur dioxide or hydrogen sulfide or hydrogen fluoride
6004		Ammonia/Methylamine	Ammonia and methylamine
6005		Formaldehyde/Organic vapor	Formaldehyde and certain organic vapors ¹
6006		Multi-Gas/Vapor	Certain organic vapors, chlorine, hydrogen chloride, chlorine dioxide, sulfur dioxide, hydrogen sulfide, ammonia/methylamine, formaldehyde or hydrogen fluoride ²

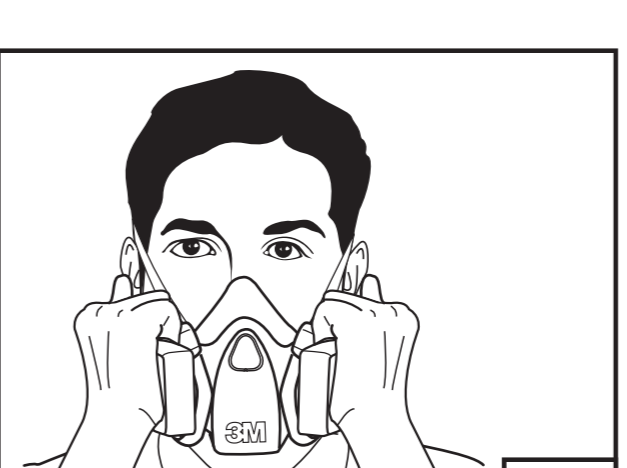
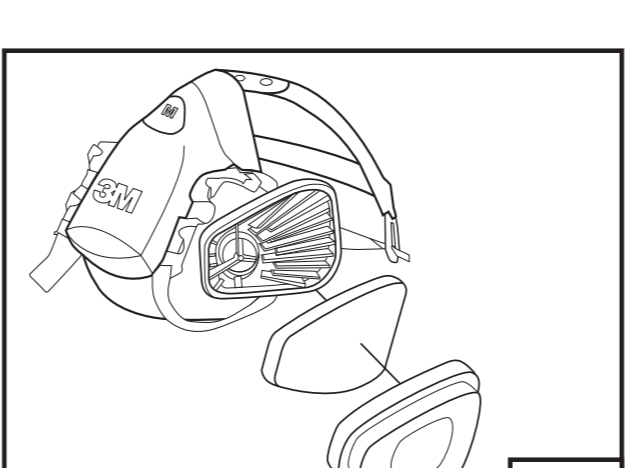
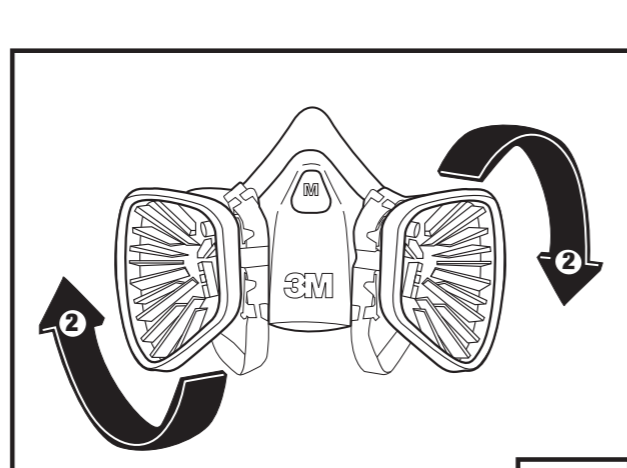
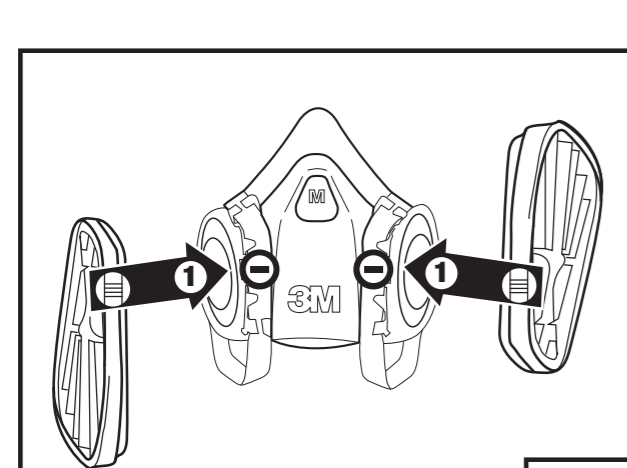
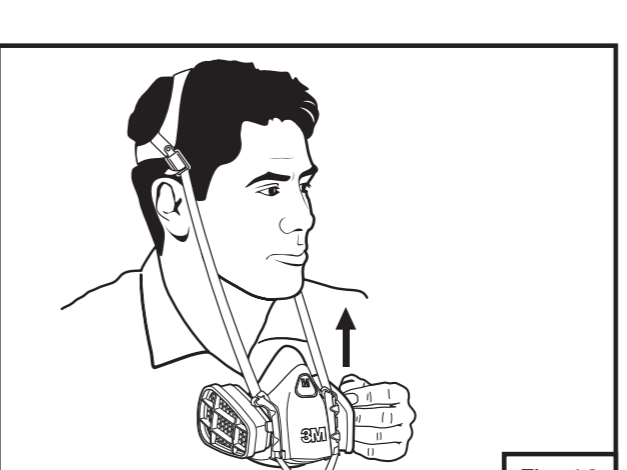
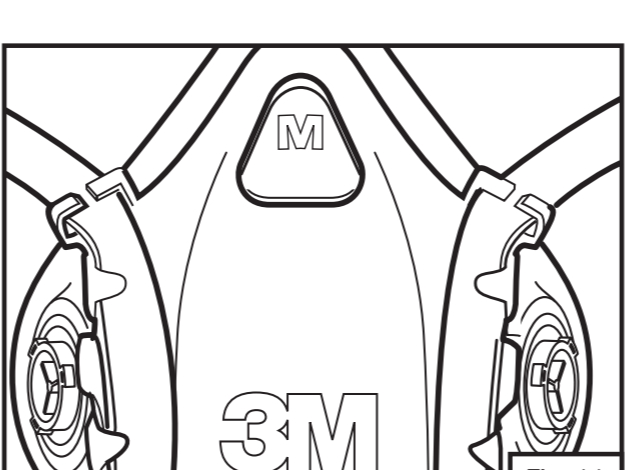
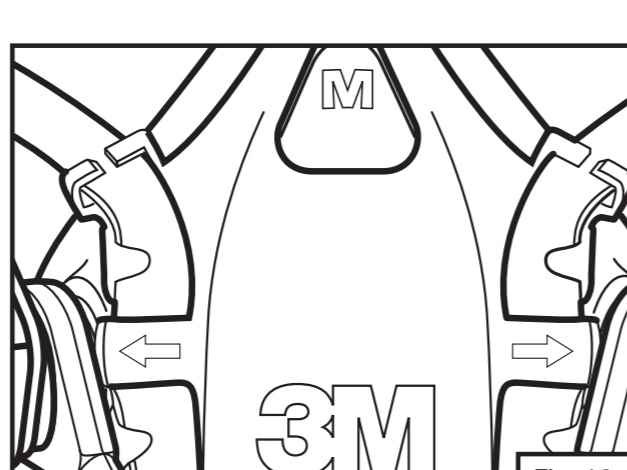
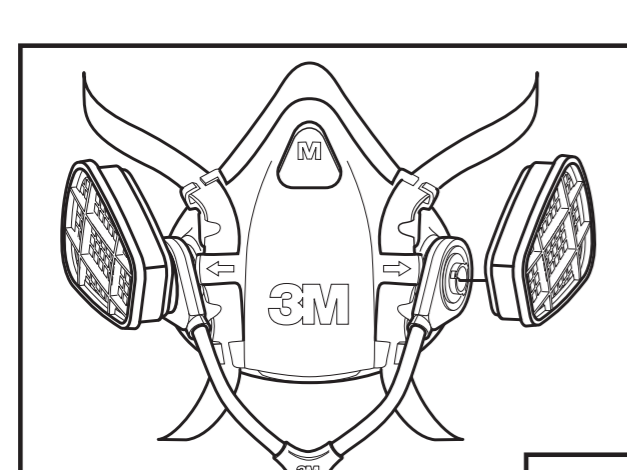
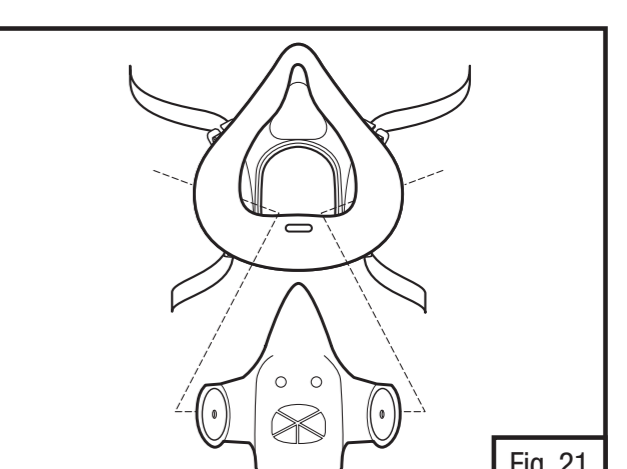
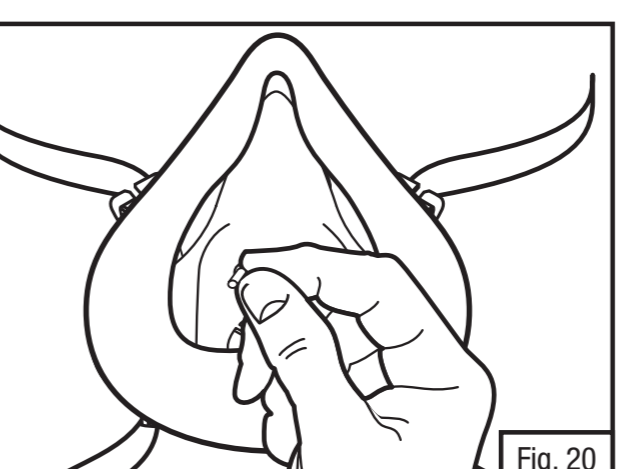
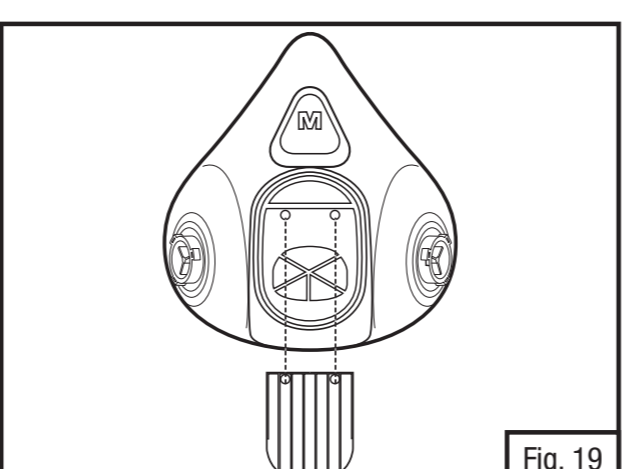
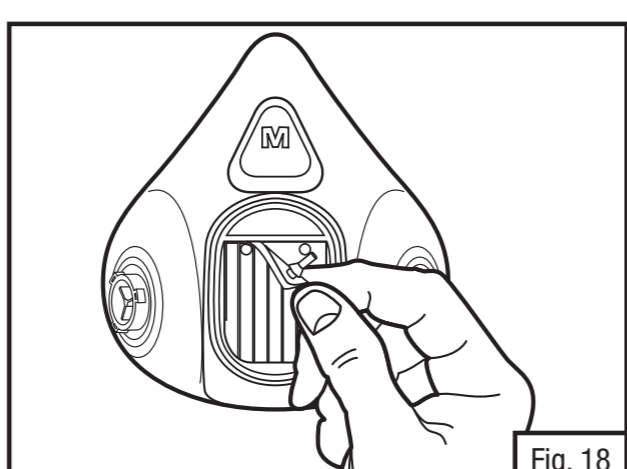
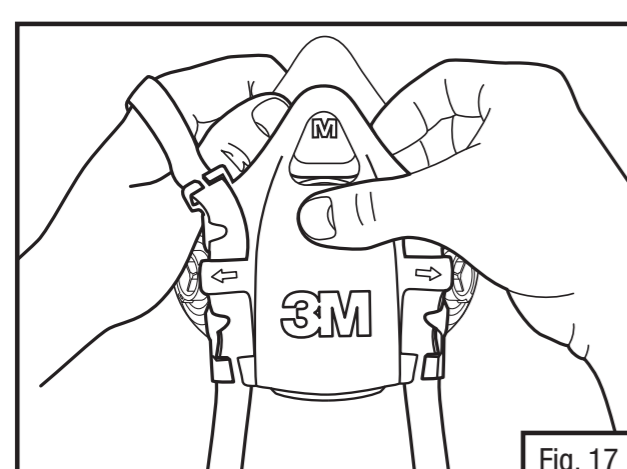
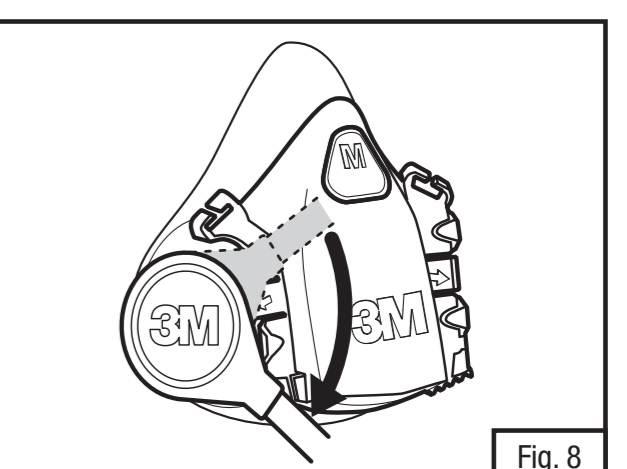
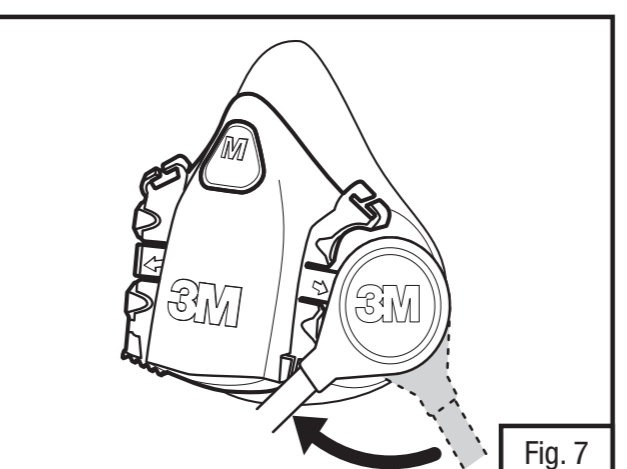
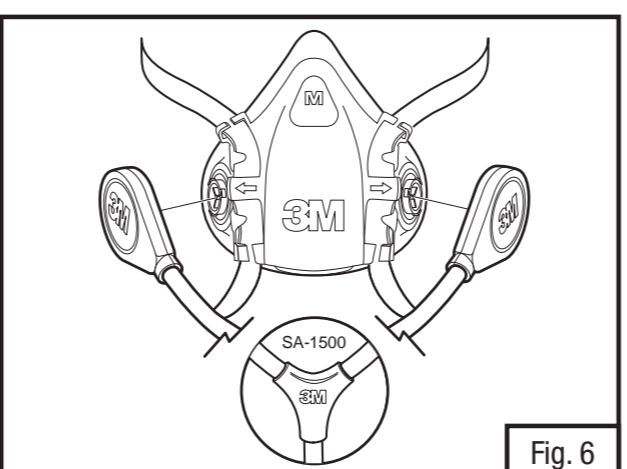
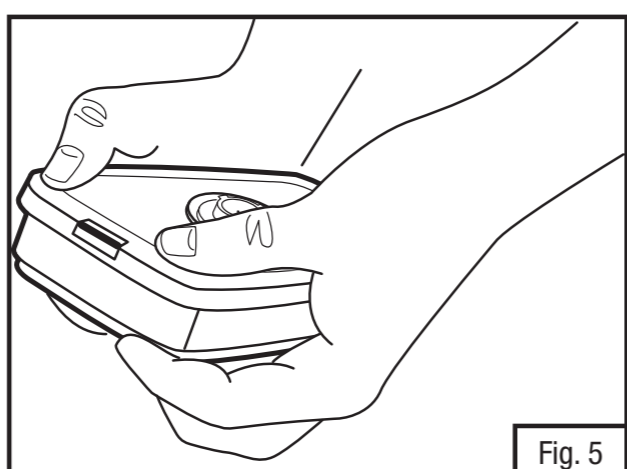
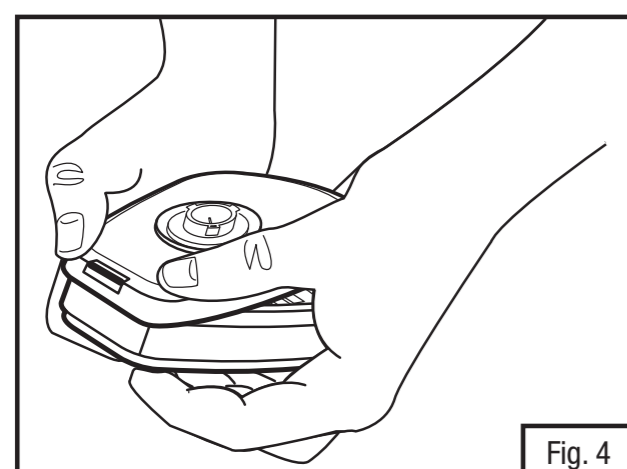
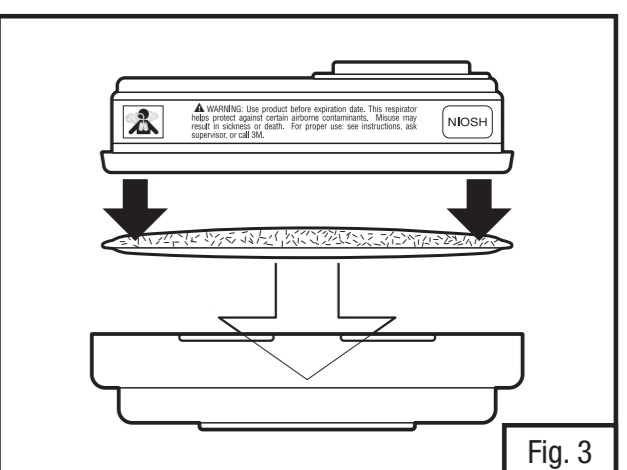
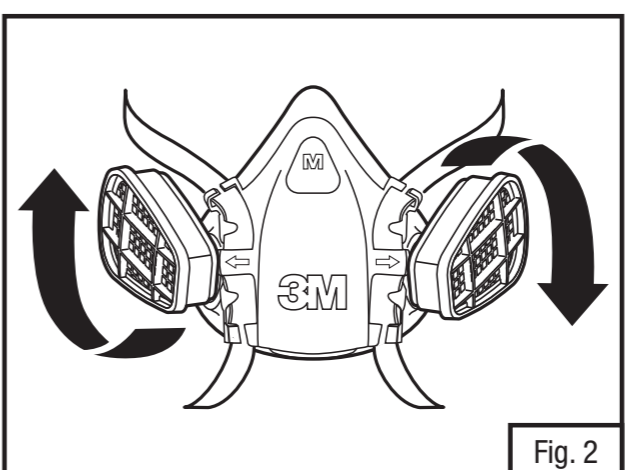
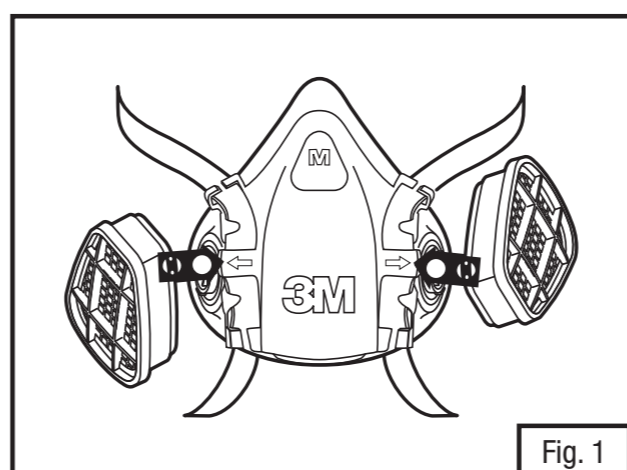
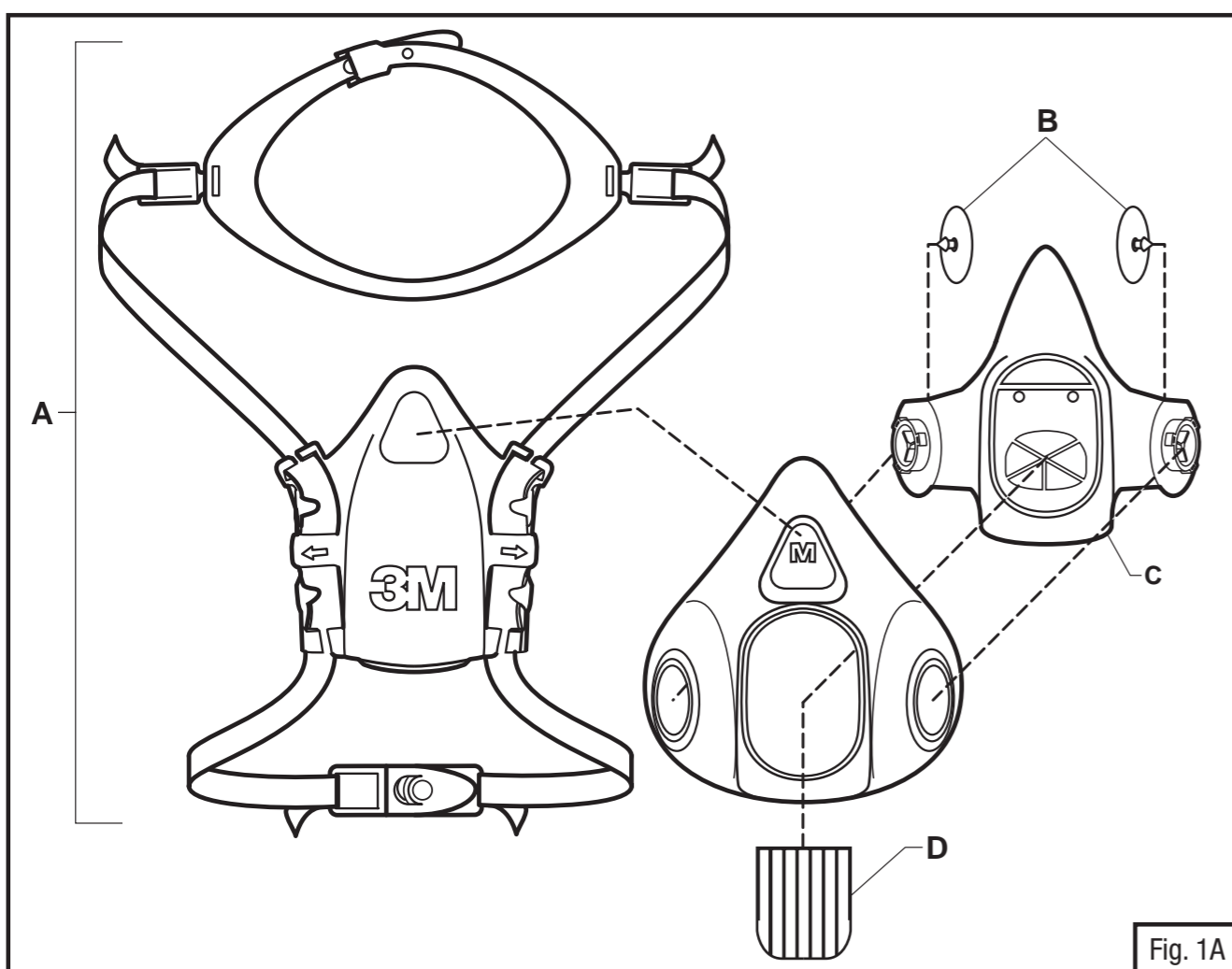

6009S		Mercury Vapor/Sulfur Dioxide/Chlorine Gas	Mercury vapor, sulfur dioxide or chlorine gas
60921		Organic Vapor/P100	Certain organic vapors and particulates
60921i		Organic Vapor with Service Life Indicator/P100	Certain organic vapors and particulates
60922		Acid Gas/P100	Chlorine, hydrogen chloride, and sulfur dioxide or chlorine dioxide or hydrogen sulfide and particulates
60923		Organic Vapor/Acid Gas/P100	Certain organic vapors, chlorine, hydrogen chloride, and sulfur dioxide or hydrogen sulfide or hydrogen fluoride and particulates
60924		Ammonia/Methylamine/P100	Ammonia and methylamine and particulates
60925		Formaldehyde/Organic Vapor/P100	Formaldehyde and certain organic vapors and particulates ¹
60926		Multi-Gas/Vapor/P100	Certain organic vapors, chlorine, hydrogen chloride, chlorine dioxide, sulfur dioxide, hydrogen sulfide, ammonia/methylamine, formaldehyde or hydrogen fluoride and particulates ¹
60928		Organic Vapor/Acid Gas/P100	Certain organic vapors, chlorine, hydrogen chloride, and sulfur dioxide or hydrogen sulfide or hydrogen fluoride and particulates ²
60929S		Mercury Vapor/Sulfur Dioxide/Chlorine Gas/P100	Mercury vapor, sulfur dioxide or chlorine gas and particulates

**** AAD part numbers are catalog numbers only. NIOSH approved as PSD part numbers

¹ OSHA regulations require gas proof goggles be worn with half facepiece respirators when used against formaldehyde.

² 3M recommended for use against methylbromide or radiiodine up to 5 ppm with daily cartridge replacement.

NOTE: Not NIOSH approved for use against methylbromide or radiiodine.

Service Life of Chemical Cartridges and Particulate Filters

3M™ Cartridges 6000 Series should be used before the expiration date on cartridge packaging. The useful service life of these cartridges will depend upon the activity of the wearer (breathing rate), specific type, volatility and concentration of contaminants and environmental conditions such as humidity, pressure, and temperature. Cartridges must be replaced in accordance with an end of service life indicator (ESLI), established change schedule, regulations, or earlier if smell, taste or irritation from the contaminant is detected.

Particulate filters must be replaced if they become damaged, soiled or if increased breathing resistance occurs. N-series should not be used in environments containing oils. R-series filters may be limited to 8 hours of continuous or intermittent use if oil aerosols are present. In environments containing only oil aerosols, P-series filters should be replaced after 40 hours of use or 30 days, whichever is first.

3M™ Filters/Adapters/Retainers

NOTE: Only 3M™ Filters approved under NIOSH 42 CFR 84 are to be used with the 3M™ Half Facepiece 7500 Series.

Number	****AAD	Description
501	07054	Filter Retainer for Filters 5N11 and 5P71
502		Filter Adapter for Filters 2000 Series and 7093/7093C
603		Filter Adapter for Filters 5N11, 5P71 with Filter Retainer 501
2071		Particulate Filter, P95
2076HF		Particulate Filter, P95, hydrogen fluoride, with nuisance level acid gas relief ¹
2078		Particulate Filter, P95, 3M recommended ozone protection ² , with nuisance level organic vapor/acid gas relief ¹
2091	07000	Particulate Filter, P100
2291		Advanced Particulate Filter, P100
2096		Particulate Filter, P100, with nuisance level acid gas relief ¹
2296		Advanced Particulate Filter, P100, with nuisance level acid gas relief ¹
2097	07184	Particulate Filter, P100, 3M recommended for ozone protection ² , nuisance level organic vapor relief ¹
2297		Advanced Particulate Filter, P100, 3M recommended for ozone protection ² , nuisance level organic vapor relief ¹
5N11		Particulate Filter, N95
5P71	07194	Particulate Filter, P95
7093		Particulate Filter, P100
7093C	37173	Particulate Filter, P100, hydrogen fluoride with nuisance level organic vapor/acid gas relief ¹

**** AAD part numbers are catalog numbers only. NIOSH approved as PSD part numbers

¹ 3M recommended for relief against nuisance levels of acid gases or organic vapors. Nuisance level refers to concentrations not exceeding OSHA PEL or applicable government occupational exposure limits, whichever is lower. Do not use for respiratory protection against acid gases or organic vapors.

² 3M recommended for ozone protection up to 10 times the OSHA PEL or applicable government occupational exposure limits, whichever is lower. **NOTE: Not NIOSH approved for use against ozone.**

Assembly of 3M™ Combination Dual Airline Breathing Tubes with Cartridges and/or Filters

The SA-1600 (front-mounted) and SA-2600 *(37001) (back-mounted) versions of the 3M™ Dual Airline Breathing Tubes allow use of selected, NIOSH-approved 6000 series cartridges and 2000 Series filters. For listing of approved cartridges and filters, reference NIOSH approval label included with 3M dual airline breathing tubes with cartridges and/or filters.

- Attach SA-1600 or SA-2600 breathing tubes to facepiece per the procedures outlined previously. The procedure is identical to the SA-1500 and SA-2500 *(07148) models.
- Make a selection of cartridges and/or filters that meets your respiratory protection requirements, and attach to the outer bayonets of SA-1600 or SA-2600 breathing tubes (Fig. 9).
- Don facepieces per procedures outlined in Donning Respirator instructions.
- After being properly fit tested, perform a positive and negative pressure user seal check each time the respirator is donned per procedures outlined in User Seal Check instructions.

If you cannot achieve a proper fit, DO NOT enter contaminated area. See your supervisor.

Using the 3M™ Combination Dual Airline Breathing Tubes without Cartridges and/or Filters

To use the 3M™ Breathing Tubes SA-1600 or SA-2600 *(37001) without cartridges or filters, attach a 3M™ Bayonet Cap 6880 *(37002) to each outer bayonet mount on the breathing tube. When used as a straight, Type C, continuous flow supplied air respirator, the Assigned Protection Factor is 50 times the PEL or TLV guidelines for half facepiece respirators.

FITTING INSTRUCTIONS

Must be followed each time respirator is worn.

The 7500 series half facepiece suspension can be configured as a standard fixed suspension or a drop down suspension for individuals using hard hats. Position straps beneath locking tabs for standard fixed suspension (Fig. 10) or position straps over locking tabs for optional drop down suspension (Fig. 11).

NOTE: Do not use with beards or other facial hair or other conditions that prevent a good seal between the face and the facepiece of the respirator. To help maintain a good seal between the face and the facepiece all hair, hoods, or other equipment must be kept out of respirator facepiece area at all times.

Donning (Standard Suspension)

- Adjust head cradle size as needed to fit comfortably on head. Place the respirator over the mouth and nose, then pull the head harness over the crown of the head. Grasp the bottom straps, place them at the back of the neck and hook them together.
- Pull the ends of the straps to adjust the tightness. Do not over-tighten (Fig. 13).
- Perform a positive and/or negative pressure user seal check each time the respirator is donned.

If you cannot achieve a proper fit, DO NOT enter contaminated area. See your supervisor.

Donning (Drop Down Suspension)

- Adjust head cradle size as needed to fit comfortably on head.
- While holding head harness strap ends with one hand, slide the facepiece up onto your face (Fig. 12). Next grasp strap ends with each hand and hook them together at back of neck.
- Adjust strap tension by pulling strap ends until a secure fit is obtained. Balance strap tension by adjusting at top and bottom strap buckles. Do not over tighten. (Strap tension may be decreased by pushing out on back side of buckles.)
- Perform a positive and/or negative pressure user seal check each time the respirator is donned. **If you cannot achieve a proper seal, DO NOT enter contaminated area. See your supervisor.**

User Seal Checks

Always check the seal of the respirator on your face before entering a contaminated area.

Positive Pressure User Seal Check

- Cover the opening in exhalation valve cover with hand and exhale gently (Fig. 14). If facepiece bulges slightly and no air leaks are detected between your face and facepiece, a proper seal has been obtained.
- If facepiece air leakage is detected, reposition respirator on your face and/or readjust tension of the elastic straps to eliminate leakage.

If you cannot achieve a proper seal, DO NOT enter contaminated area. See your supervisor.

Negative Pressure User Seal Check (with 6000 Series Cartridges)

NOTE: Use of 3M™ Filter Retainer 501 may aid respirator wearer in conducting a negative pressure user seal check.

- Place palms of hands to cover face of cartridge or open area of 3M™ Filter Retainer 501 *(07054), when retainer is attached to the cartridge, to restrict air flow (Fig. 15).
- Inhale gently. If you feel facepiece collapse slightly and pull closer to your face with no leaks between the face and facepiece, a proper seal has been obtained.
- If facepiece air leakage is detected, reposition respirator on face and/or readjust tension of straps to eliminate air leakage.

If you cannot achieve a proper seal, DO NOT enter contaminated area. See your supervisor.

Negative Pressure User Seal Check (with 2000 series filters)

- Place your thumbs onto the center portion of the filters, restricting airflow into the breathing tube of filters, and inhale gently. If you feel facepiece collapse slightly and pull closer to your face with no leaks between the face and facepiece, a proper seal has been obtained (Fig. 16).
- If facepiece air leakage is detected, reposition respirator on face and/or readjust tension of straps to eliminate the leakage.

If you cannot achieve a proper seal, DO NOT enter contaminated area. See your supervisor.

3M™ Exhalation Valve

- Remove 3M™ Valve Cover/Head Harness Assembly 7581 by pulling away from facepiece (Fig. 17).
- Remove 3M™ Exhalation Valve 7583 from valve seat by pulling each valve stem separately from holes (Fig. 18).
- Replace 3M™ Exhalation Valve 7583 by inserting stems and pulling through from opposite side until they are both snapped in place (Fig. 19 and 20).
- Replace 3M™ Valve Cover/Head Harness Assembly 7581.

Note: Conduct a negative pressure seal check to ensure exhalation valve is functioning properly.

3M™ Inhalation Valve

- Remove 3M™ Inhalation Valve 7582 by grasping and pulling valve stem from seat.
- Replace valve by pressing stem into hole and manipulating stem tip until valve seats completely.

3M™ Cartridge/Filter Holder

- Remove 3M™ Valve Cover/Head Harness Assembly 7581 by pulling away from facepiece (Fig. 17).
- Pull facepiece from 3M™ Cartridge/Filter Holder 7586. (Fig. 21)
- Replace 3M™ Cartridge/Filter Holder 7586 by aligning with facepiece and fully engaging holder ports with holes in facepiece.
- Replace 3M™ Valve Cover/Head Harness Assembly 7581 by snapping into place.

3M™ Particulate Filters must be immediately changed when an increase in breathing resistance is noticed.

In Brazil, the 3M™ Filter 59358R can be used with the Filter Adaptor 603 and the Filter Retainer 501 on the 3M™ Half Facepiece 7500 Series.

ASSEMBLY INSTRUCTIONS

3M™ Cartridge Assembly 6000 Series

Align cartridge notch with arrow on facepiece, as shown, and push together (Fig. 1). Turn cartridge clockwise to stop (1/4 turn) (Fig. 2).

3M™ Filter Assembly 5N11 and 5P71

- Place filter into 3M™ Retainer 501 *(07054) so printed side of filter faces the cartridge (Fig. 3).
- Press cartridge into filter retainer. It should snap securely into filter retainer. When correctly installed, filter should completely cover face of cartridge.
- To replace filter, remove retainer by lifting on TAB.

3M™ Filters, 2000 Series and 7093/7093C Filter Assembly

Align opening of filter with filter attachment on facepiece. Turn filter clockwise until it is firmly seated and cannot be further turned. Repeat for second filter.

3M™ Filter Adapter 502 Assembly and Filter Attachment

- Align adapter over cartridge. Engage front snap by squeezing front of cartridge and adapter together, placing thumbs of both hands over top of adapter and fingers along bottom sides of cartridge (Fig. 4).
- Engage back snap by squeezing back side of cartridge and adapter together using the same hand positions (Fig. 5). An audible click should be heard as each snap is engaged.
- Place filter onto the filter holder so that filter comes into even contact with gasket. Twist clockwise a quarter turn until it is firmly seated and filter cannot be turned further. Repeat for second filter.

NOTE: The 3M™ Filter Adapter 502, once installed on a 3M™ Cartridge 6000 Series, is not to be removed or reused. Removal or reuse may result in leakage, overexposure, sickness or death.

3M™ Filters, 2000 Series and 7093/7093C with 3M™ Filter Adapter 502

Place filter onto the filter holder so that filter comes into even contact with gasket. Twist clockwise one quarter, turn until it is firmly seated and filter cannot be turned further. Repeat for second filter.

NOTE: The 3M™ Filter Adapter 502, once installed on a 3M™ Cartridge 6000 Series, is not to be removed or reused. Removal or reuse may result in leakage, overexposure, sickness or death.

3M™ Filter Adapter 603 Assembly and 5N11 or 5P71 Filter Attachment

- Align notch on edge of 603 adapter with facepiece mark as shown (Fig. 22).
- Turn adapter 1/4 turn clockwise to stop. To remove adapter, turn 1/4 turn counterclockwise (Fig. 23).
- Place filter into 501 retainer with filter printing facing towards the 603 adapter. Snap together and ensure the filter seal is free from creases or gaps (Fig. 24).

In Brazil, the 59358R Filter used with the 603 adaptor is assembled following the same procedures as the 5N11 and 5P71.

3M™ Supplied Air Systems

▲ WARNING

To meet the U.S. National Institute for Occupational Safety and Health (NIOSH) requirement for minimum (4 CFM/115 lpm) and maximum (15 CFM/424 lpm) air flow; the air control valves approved for use with the 3M™ Half Facepiece Respirators 7500 Series must be operated within the correct supply pressure ranges and hose lengths. **Failure to do so may result in sickness or death.**

In Brazil, the Brazilian Association of Technical Standards (ABNT) NBR 14372 requires a minimum of 120 lpm and maximum of 280 lpm air flow for breathing air for half and full facepiece respirators.

▲ WARNING

OSHA standard 29 CFR 1910.134 requires that employers provide breathing air which shall "meet at least the requirements of the specification for Grade D breathing air as described in Compressed Gas Association Commodity specification G-7.1-1997" in the United States. In Canada, breathing air systems must be supplied air which meets at least the requirements of CSA Standard Z180.1. **Failure to do so may result in sickness or death.**

In Brazil breathing air systems must be supplied with air, which meets ANSI Z86.1-1989/CGA G-7.1, Grade D breathing air.
--

Assembly of 3M™ Dual Airline Breathing Tubes

- Hold the facepiece in front of you so that the 3M logo is facing you. Align the two branches of the breathing tube over the two bayonet mounts on facepiece. For the 3M™ Breathing Tubes SA-1500 or SA-1600, make sure that 3M logo on breathing tube and on half facepiece are both facing towards you. For 3M™ Breathing Tubes SA-2500 *(07148) or SA-2600 *(37001), make sure that the 3M logo on breathing tube is facing in opposite direction to 3M logo on half facepieces (Fig. 6). SA-1500/SA-2500 shown.
- Twist each branch of breathing tube clockwise a quarter turn until it is firmly seated in the bayonet and cannot be turned further (Fig. 7 and 8). Do not forcibly overturn as the bayonet could be damaged. SA-1500/SA-2500 shown.
- Attach airline to approved air regulators per pressure schedules in dual airline, supplied air respirators *User Instructions*.

Negative Pressure User Seal Check (with 7093/7093C filters)

- Using hands press or squeeze filter covers toward facepiece and inhale gently. If you feel facepiece collapse slightly and pull closer to your face with no leaks between the face and facepiece a proper seal has been obtained. (Fig. 25).
- If facepiece air leakage is detected, reposition respirator on face and/or readjust tension of straps to eliminate the leakage.

If you cannot achieve a proper seal, DO NOT enter contaminated area. See your supervisor.

Negative Pressure User Seal Check with Dual Airline

- Disconnect airline hose from air control valve.
- With breathing tube still connected to the air control valve inhale gently. If you feel facepiece collapse slightly and pull closer to your face with no leaks between the face and facepiece, a proper seal has been obtained.
- For combination dual airline where cartridges or filters are attached perform user seal check as described above under the appropriate cartridge or filter that is being used.
- If facepiece air leakage is detected, reposition the respirator on your face and/or readjust the tension of the straps to eliminate the leakage and recheck seal.

If you cannot achieve a proper seal, DO NOT enter contaminated area. See your supervisor.

NOTE: Before assigning any respirator to be worn in a contaminated area, a qualitative or quantitative fit test must be performed per OSHA Standard 1910.134 or CSA Standard Z94.4.

Fit Testing

The effectiveness of a respirator will be reduced if it is not fitted properly. Therefore, either quantitative or qualitative fit testing must be conducted prior to the respirator being issued and used.

NOTE: Fit testing is a U.S. Occupational Safety and Health Administration (OSHA), a Canadian CSA and a Brazilian BMOL requirement.

Quantitative Fit Testing

To conduct a quantitative fit test (QNFT) with the 3M™ Half Respirator Facepiece, 7501 *(37081), 7502 *(37082), 7503 *(37083), place a 3M™ Fit Test Adapter 601 on either side of the half facepiece. Place a 3M™ Filter 2091 or 3M™ Filter P100 7093 on the 601 fit test adapter and the other side of the half facepiece.

Qualitative Fit Testing

Qualitative Fit Testing (QLFT) can be conducted with any approved particulate filters. The FT-10 (sweet) or FT-30 (bitter) QLFT fit test can be utilized to conduct the fit testing.

Fit testing should be conducted using the heaviest cartridge, canister, filter or combination that each wearer will use in their work environment. Respirators should also be fit tested while wearing any personal protective equipment (PPE) the wearer may use in their work environment that may affect the fit of the respirator (e.g. hoods, hardhats, safety glasses, hearing protections, etc.).

INSPECTIONS, CLEANING AND STORAGE

Inspection Procedure

This respirator must be inspected before each use to ensure it is in proper operating condition. Any damaged or defective parts must be replaced before use. The following procedure is recommended:

- Check the facepiece for cracks, tears and dirt. Examine the inhalation valves for signs of distortion, cracking or tearing.
- Check that the head straps are intact and have good elasticity.
- Examine all plastic parts and gasket areas for signs of cracking or fatiguing and replace if necessary. Remove the exhalation valve cover and examine the exhalation valve and seat for signs of dirt, distortion, cracking, or tearing. Replace the valve if necessary. Secure the valve cover prior to use (Fig. 17).

Cleaning and Storage

Cleaning is recommended after each use

▲ WARNING

Do not clean with solvents. Cleaning with solvents may degrade some respirator components and reduce respirator effectiveness. Inspect all respirator components before each use to ensure proper operating condition. Failure to do so may result in sickness or death.
--

- Remove cartridges and/or filters.
- Clean facepiece (excluding filters and cartridges), with 3M™ Respirator Wipes 504 *(07065) (not to be used as the only method of cleaning) or by immersing in warm cleaning solution, water temperature not to exceed 120°F; and scrub with soft brush until clean. Add neutral detergent if necessary. Do not use cleaners containing lanolin or other oils.
- Disinfect facepiece by soaking in a solution of quaternary ammonia disinfectant or sodium hypochlorite (1 oz. [30 ML] household bleach in 2 gallons [7.5 L] of water), or other disinfectant.
- Rinse in fresh, warm water and air dry in non-contaminated atmosphere.
- The cleaned respirator should be stored away from contaminated areas when not in use.

REPLACEMENT INSTRUCTIONS

3M™ Head Harness Assembly

- Remove 3M™ Valve Cover/Head Harness Assembly 7581 by pulling away from facepiece (Fig. 17).
- Replace 3M™ Valve Cover/Head Harness Assembly 7581 by aligning parts and snapping together. When properly engaged an audible snap should be heard.

For Compliance in Brazil NOTE:

- Do not use in deficient or enriched oxygen atmospheres.
- Storage, Transportation and Care: store in a clean and dry place and away from contaminants and extreme temperature and humidity.
- The components of this respirator are made of materials which are not expected to cause adverse health effects.
- It is necessary to have special care to use this product in explosives atmospheres.

Product Manufacturing Date

The parts of the product show markings that bring information of manufacturing date, and its reading is described as in the example below:

Date Code = 12th month 1999 (12/99)

Date Code = First Quarter 2002

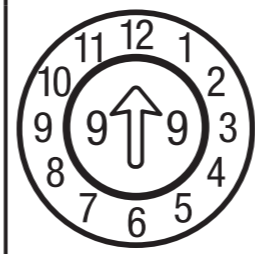

02	03	04	05	06
.				